

Gold Balance

FX-GD

Series

Finally, a balance worth its weight in gold

Highly compact B5 size footprint

Ultra fast 1 second stabilization

Easy to read Vacuum Fluorescent Display



FX-120GD
122gx1mg

FX-200GD
220gx1mg

FX-300GD
320gx1mg

FX-1200GD
1220gx10mg

FX-2000GD
2200gx10mg

FX-3000GD
3200gx10mg

SHS Super Hybrid Sensor 888 VFD Display 44A Accuracy Improvement GLP RS-232C FDC Full Digital Calibration COMPARATOR ON/OFF Buzzer Function ID LAN USB SCF Statistical Calculation Function



A&D ...Clearly a Better Value
A&D Company, Limited
<http://www.aandd.jp>

Gold Balance

FX-GD Series



Specifications

	FX-120GD	FX-200GD	FX-300GD	FX-1200GD	FX-2000GD	FX-3000GD
Weighing capacity	122g	220g	320g	1220g	2200g	3200g
Minimum weighing value (1 digit)		0.001g			0.01g	
Counting mode	Minimum unit mass	0.001g			0.01g	
	Number of samples	5, 10, 25, 50 or 100 pieces				
Percent mode	Minimum 100% reference mass	0.100g			1.00g	
	Minimum 100% display	0.01%, 0.1%, 1% (depends on the reference mass stored)				
Repeatability (Standard Deviation)		0.001g			0.01g	
Linearity		±0.002g			±0.02g	
Stabilization time (typically set at FAST)	Approx. 1 second					
Sensitivity drift (10°C to 30°C/50°F to 86°F)	±2ppm / °C					
Operating temperature	5°C to 40°C (41°F to 104°F), 85%RH or less (no condensation)					
Display type	Vacuum Fluorescent Display (VFD)					
Display refresh rate	5 times / second, 10 times / second or 20 times / second					
Standard serial interface	RS-232C					
Weighing pan (diameter)	130mm			150mm		
External calibration mass	100g	200g	300g	1000g	2000g	3000g
	50g	100g	200g 100g	500g	1000g	2000g 1000g
AC adaptor	Confirm that the adaptor type is correct for the local voltage and power receptacle					
Power consumption	Approx. 11VA (supplied to the AC adaptor)					
External dimensions	193 (W) X 262.5 (D) X 85.5 (H) mm					
Net weight	Approx. 2.5kg					

Options

- FXi-02*** Quick USB interface with cable
- FXi-08*** Ethernet interface with WinCT-Plus software
- FXi-09*** Built-in rechargeable battery
- FXi-10** Small breeze break
- FXi-11** Large breeze break
- FXi-15** Carrying case

* FXi-02, FXi-08 and FXi-09 cannot be used at the same time.

Accessories

- AD-1683** Static eliminator
- AD-8920** Remote display
- AD-8922** Remote controller
- AD-8121B** Compact printer
- AD-8526** Serial/Ethernet converter
- AX-USB-9P-EX** Serial/USB converter
- AX-CARATPAN-WEX** Carat pan (silver, 2pcs)
- AX-CARATPAN-BEX** Carat pan (black, 2pcs)
- AX-FXi-31** Main unit cover (5pcs)

External Dimensions (mm/inches)

Dimensions with Small Breeze Break (Comes equipped with FX-120GD/200GD/300GD)

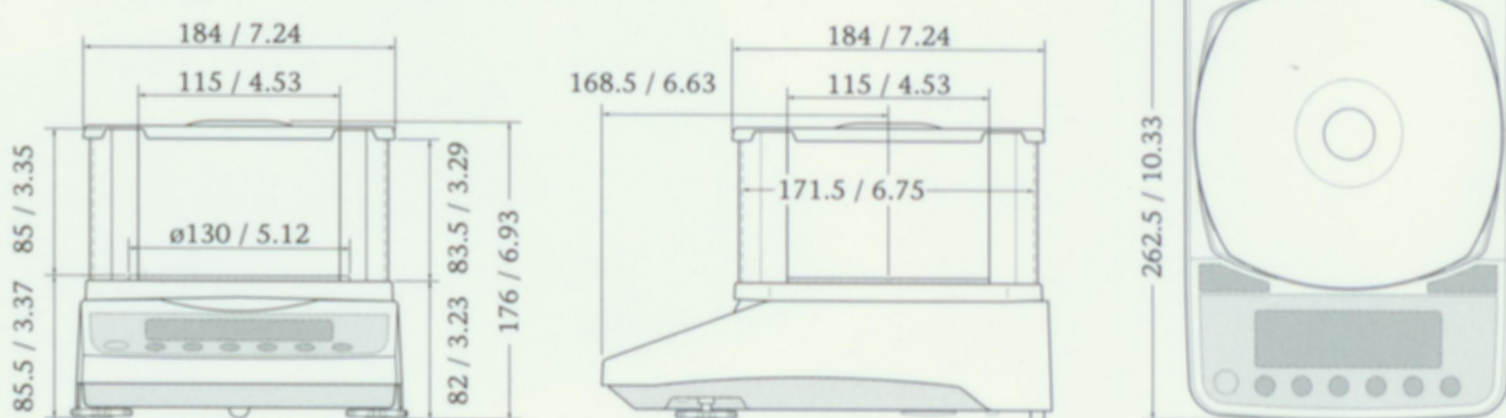

Pan size	A
FX-120GD / 200GD / 300GD	130 / 5.12
FX-1200GD / 2000GD / 3000GD	150 / 5.91

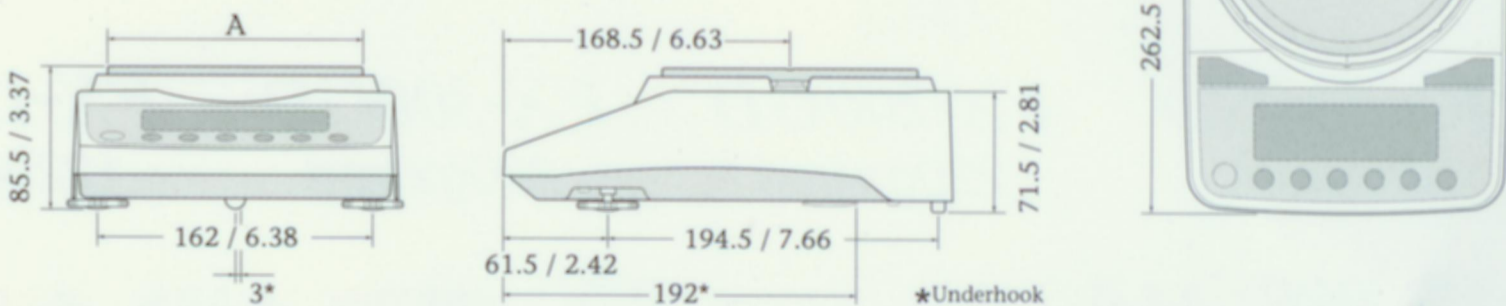

A&D ...Clearly a Better Value

A&D Company, Limited

3-23-14 Higashi-Ikebukuro, Toshima-ku, Tokyo 170-0013 JAPAN
Telephone: [81](3) 5391-6132 Fax: [81](3) 5391-6148
http://www.aandd.jp

A&D ENGINEERING, INC.

1756 Automation Parkway, San Jose, CA 95131 U.S.A.
Telephone: [1](408) 263-5333 Fax: [1](408) 263-0119

A&D MERCURY PTY. LTD.

32 Dew Street, Thebarton, South Australia 5031 AUSTRALIA
Telephone: [61](8) 8301-8100 Fax: [61](8) 8352-7409

A&D INSTRUMENTS LTD.

Unit 24/26 Blacklands Way Abingdon Business Park,
Abingdon, Oxon OX14 1DY UNITED KINGDOM
Telephone: [44](1235) 550420 Fax: [44](1235) 550485

<German Sales Office>

Große Straße 13 b 22926 Ahrensburg GERMANY
Telephone: [49](0) 4102 459230 Fax: [49](0) 4102 459231

A&D KOREA Limited

Manhattan Bldg. 8F, 36-2 Yoido-dong, Youngdeungpo-gu, Seoul, KOREA
Telephone: [82](2) 780-4101 Fax: [82](2) 782-4280

A&D RUS CO., LTD.

Vereyskaya str. 112 Kuntsevo Block, 121357,
Moscow, Russia
Telephone: [7] (495) 937-33-44 Fax: [7] (495) 937-55-66