

PerkinElmer Series 200 HPLC Systems



designed to **never** let you down

an inside look at the Series 200 HPLC systems

PerkinElmer knows you need to rely on your high performance liquid chromatography (HPLC) system to get the job done day-in and day-out. That's why we designed and built the Series 200 family of HPLC instruments.

We're confident the Series 200 HPLC family will meet and exceed the liquid chromatography demands of your lab, because each component – from pump to data handling – has proven track records behind them. Best of all, all of our systems are backed by our renowned global service and support organization, so you know you can depend on them today, tomorrow and for years to come.

The brains behind the brawn – TotalChrom CDS

Acquiring, processing, reporting, reviewing and approving data is a streamlined series of operations in PerkinElmer's TotalChrom® Chromatography Data System (CDS) software, designed to fit your laboratory workflow and maximize productivity. With its scalable architecture, 21 CFR Part 11 compliance features and proven algorithms, TotalChrom offers a computing strategy to manage your chromatography data quickly and securely in both regulated and non-regulated environments. TotalChrom data systems can be deployed in standalone, thin client, or enterprise client/server computing environments.



SoftLINK™: entry-level solution for instrument connectivity

Designed for one instrument, workstation environments, SoftLINK provides instrument connectivity at a glance.

dotLINK™: interfacing with ease

dotLINK is a Windows CE-based interface that allows you to connect your Series 200 directly to the network. Designed to face today's workload challenges and provide Ethernet connectivity, dotLINK allows external buffering with a minimal need for validation.

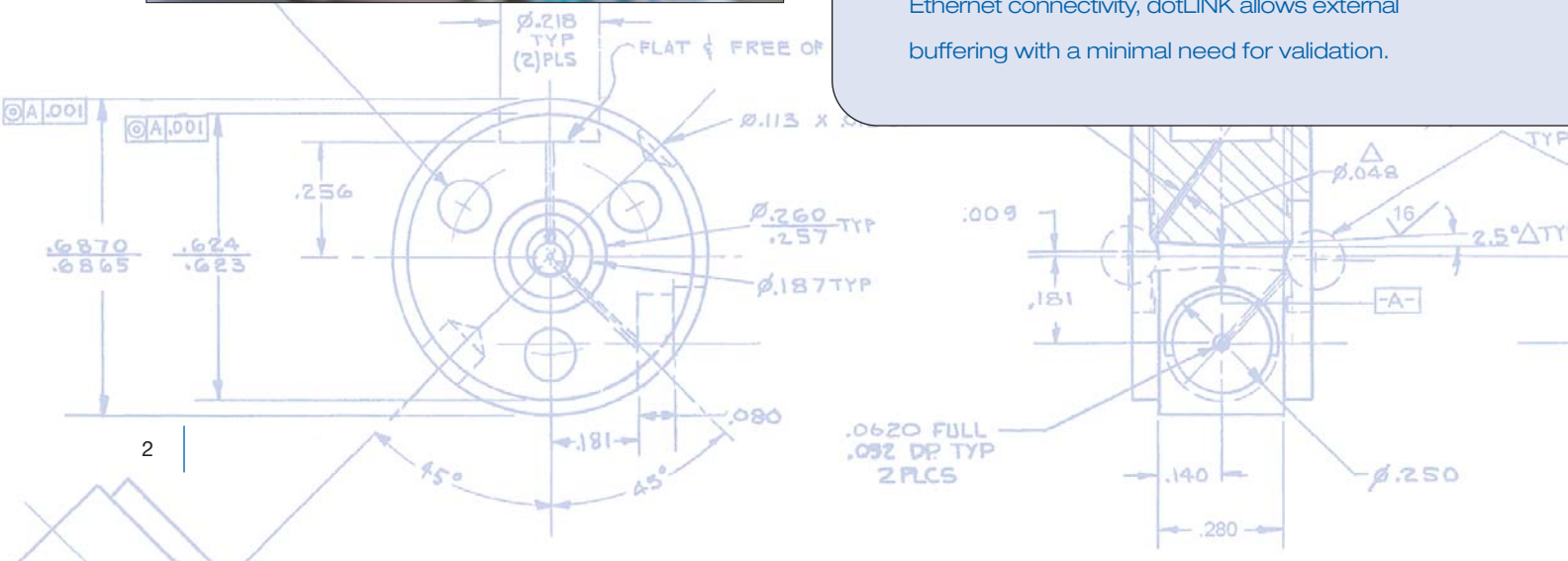

rugged and reliable – the Series 200 Analytical Pump



Designed to work in applications where minimal downtime and low maintenance are a must, the proven, rugged design of the Series 200 Analytical Pump offers low piston wear for less downtime and lower cost of ownership.

Precise blending through advanced engineering is obtained by the Series 200 using a design that allows automatic compensation of solvent compressibility during each pump stroke. This feature plus two-point flow calibration ensure greater accuracy, highly-precise flow rates, and high-performance gradient capability. True mixing volume correction using the chemist's approach is obtained precisely and reliably, run after run.

That is why thousands of laboratories worldwide have chosen to rely on PerkinElmer's unique pumping technology.

Low, precise microflows – the Series 200 Micro Pump

The Series 200 Micro Pump, with its ultra-low delay volume, is ideal for narrowbore chromatography – or as a front-end to your LC/MS. The Series 200 Micro Pump offers superior flow rate precision, compositional accuracy, and retention-time precision for either isocratic or gradient separations. The Series 200 Micro Pump is available in isocratic or binary high pressure blending with user customizable mixing. Whenever “no delay volume” and “ultra-fast gradient” are required, the Series 200 Micro Pump is the solution for your applications.

Growing platform to match your needs

Pumps can be upgraded to additional solvent capabilities right in your lab. Start with a simple isocratic and expand to binary or quaternary to match your needs.

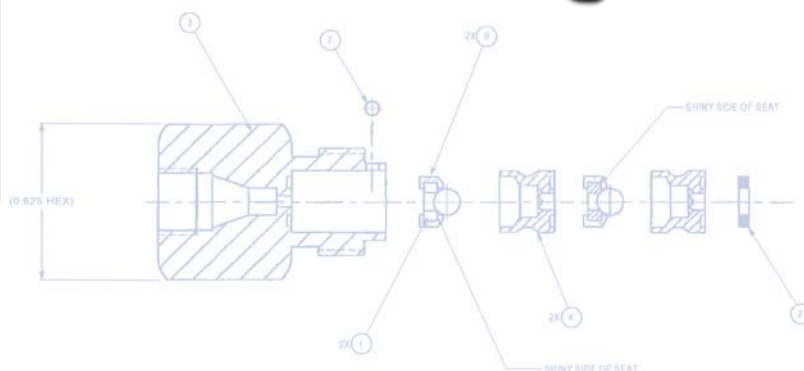
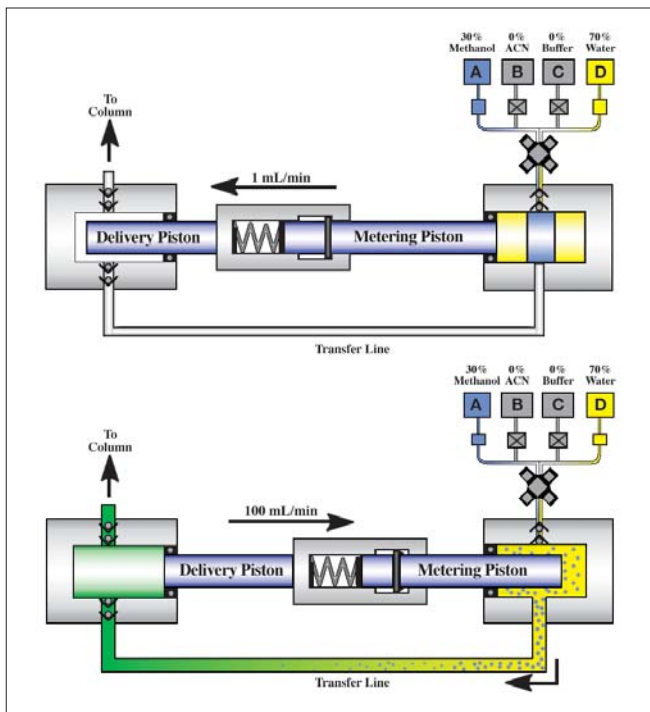

fast, accurate and flexible – the **Series 200** Autosampler

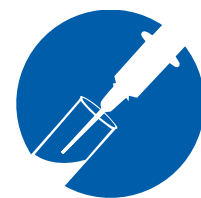

Need speed? Reliability? Flexible sampling? The Series 200 Autosampler does it all!

The Series 200 Autosampler rapidly brings the needle to the sample, eliminating the time, complexity and unreliability of moving sample vials, while providing support for numerous sample container formats. Select your injection volume, needle height and flush cycles to be able to analyze every sample in the most suitable analytical conditions.

The fast, flexible and ultra-reliable sampling – up to three injections per minute – is due to the unique, all gear-driven drive mechanism.

Key features

- Advanced design for injection valve flushing and external needle wash reduces carryover – offers a 0.005% carryover specification.
- Impressive injection linearity for uncompromised quantitative analysis and method development.
- Boasts the industry's best on-board automated derivatization/dilution performance of any analytical autosampler. It is now easy and takes little time to prepare solutions for calibration curves and internal standard (ISTD) addition.
- Easily interchangeable, cost-effective sample trays. Choose from over 13 different tray/sampling formats. High-capacity sample trays can accommodate up to 225 vials or two 96- or two 384-well plates with full control of needle level within sample vials/trays and on-board temperature control.

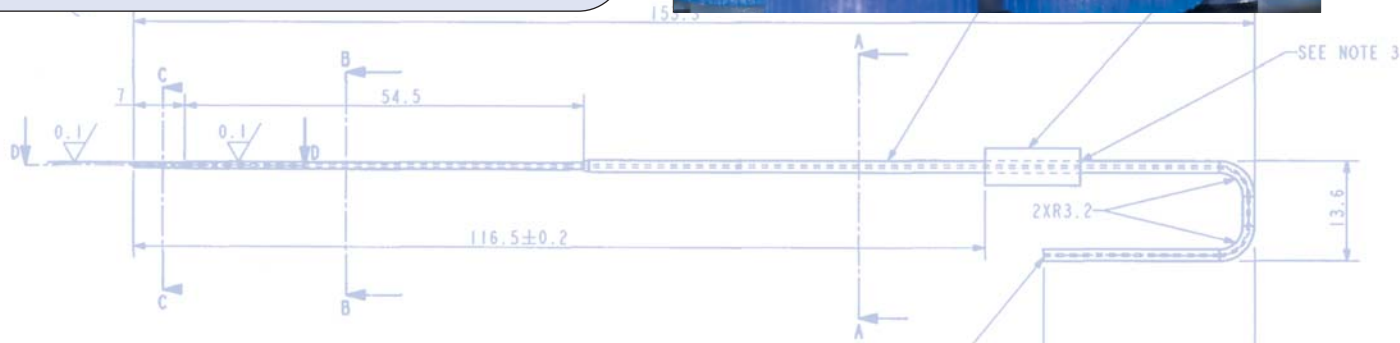
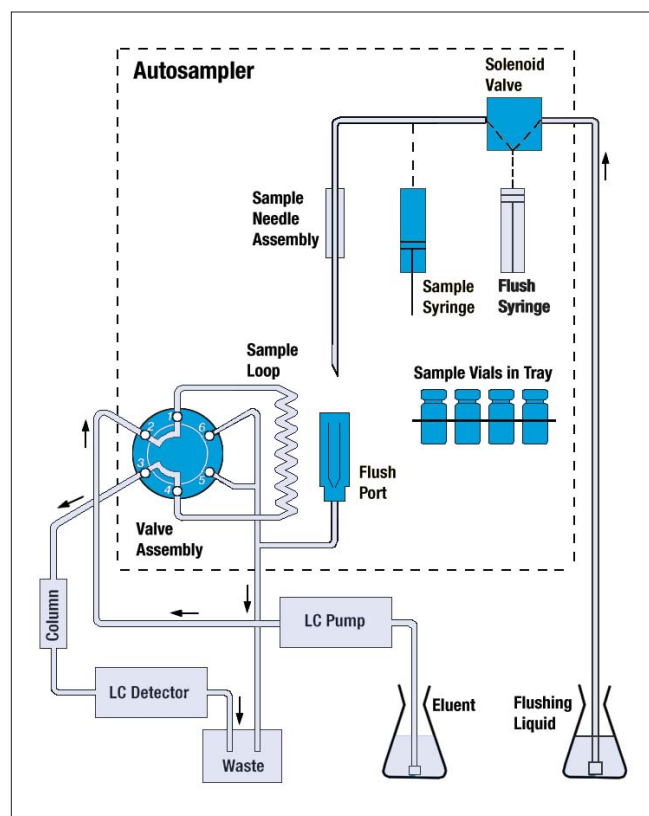

precise for increased repeatability – the **Series 200** Column Oven

The PerkinElmer Series 200 Column Oven controls the mobile phase and sample temperature before entering the column via a low dispersion built-in pre-heater. This eliminates thermal gradients across the column, resulting in better column performance and precise retention times. All heating and cooling is performed electronically, permitting sub-ambient temperatures without coolant or refrigerants.

By maintaining the column temperature at a stable set point, more standardized results can be obtained, permitting better day-to-day and lab-to-lab comparison of results. In addition, elevated temperatures can be used in many applications to decrease mobile phase viscosity while increasing mass transfer and sample

solubility, resulting in better resolution and/or increased speed of analysis. Sub-ambient temperature capabilities are helpful in many biomolecular analyses and in the analysis of some chiral compounds.

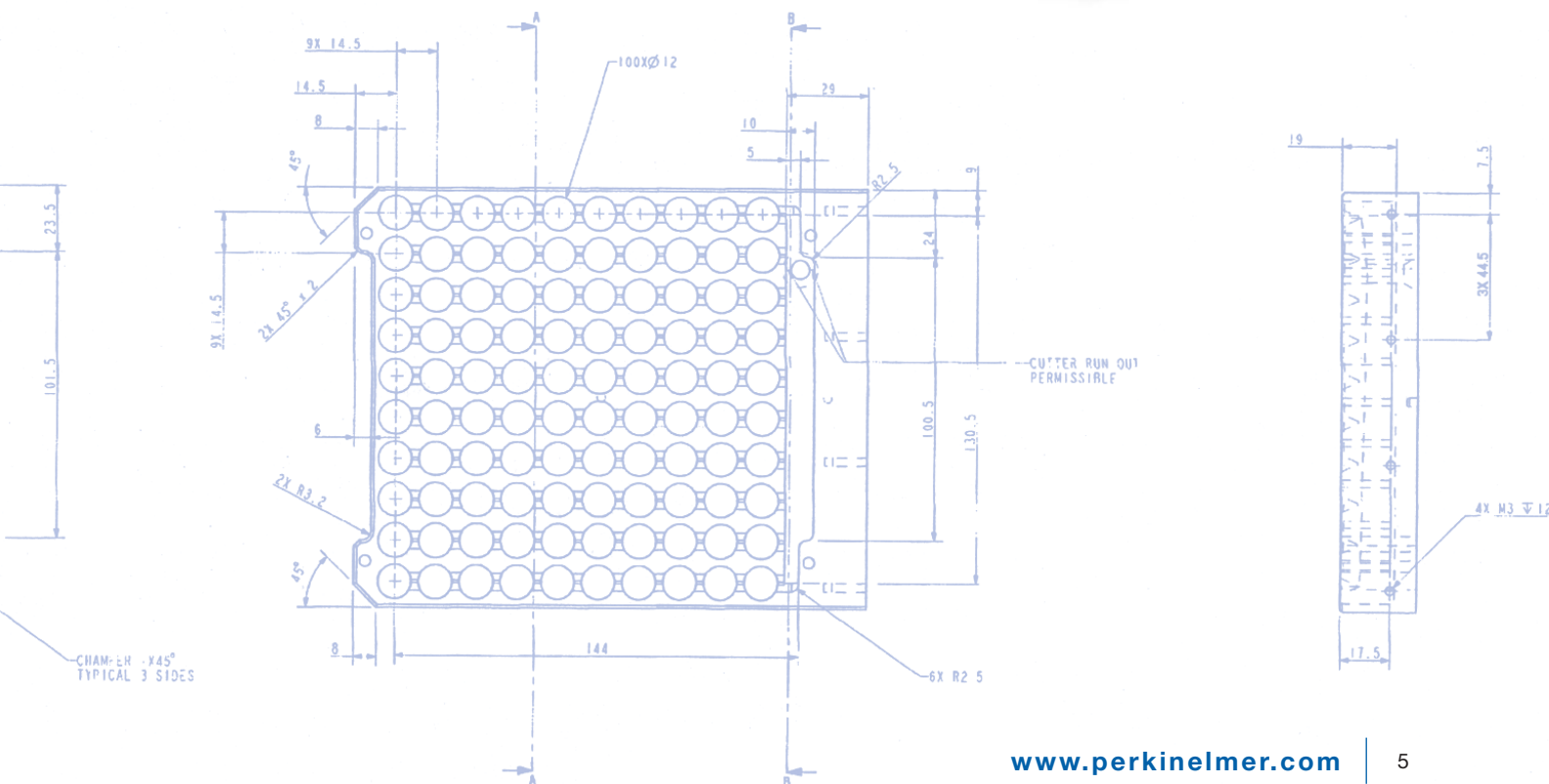
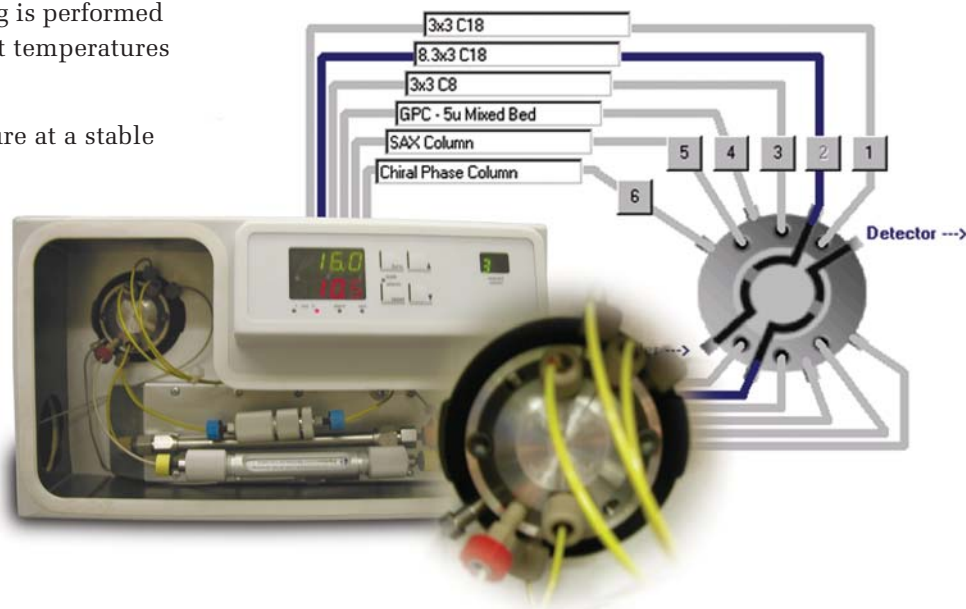

Series 200

Getting answers not just data - the Series 200 PDA

The Series 200 Photo Diode Array (PDA) Detector, provides true UV/Vis detection and high resolution spectral data. The Series 200 PDA is fully network-compatible, providing fast and secure transmission of chromatographic and spectral data.

The excellent signal-to-noise characteristics of the Series 200 Diode Array make it ideally suited for low volume or low concentration samples. In addition, the spectral data generated by the Series 200 is quickly and easily processed by our powerful IRIS™ Spectral Processing Software developed by PerkinElmer. It offers a full suite of functionality and an intuitive user interface, all protected under a fully 21 CFR Part 11 compliant architecture.

Stable and ready for any challenge - the Series 200 UV/Vis Detector

The Series 200 UV/Vis Detector is a solid foundation for your total HPLC system, offering the highest sensitivity and outstanding linearity performance – even at extremely high or low concentrations – 24 hours-a-day, seven days-a-week.

Key features

- The Series 200 UV/Vis supports the full UV/Vis range from 190 to 700 nm
- Several flow cell formats to choose from to meet your specific application requirements in analytical, semi-prep or micro-bore environments.

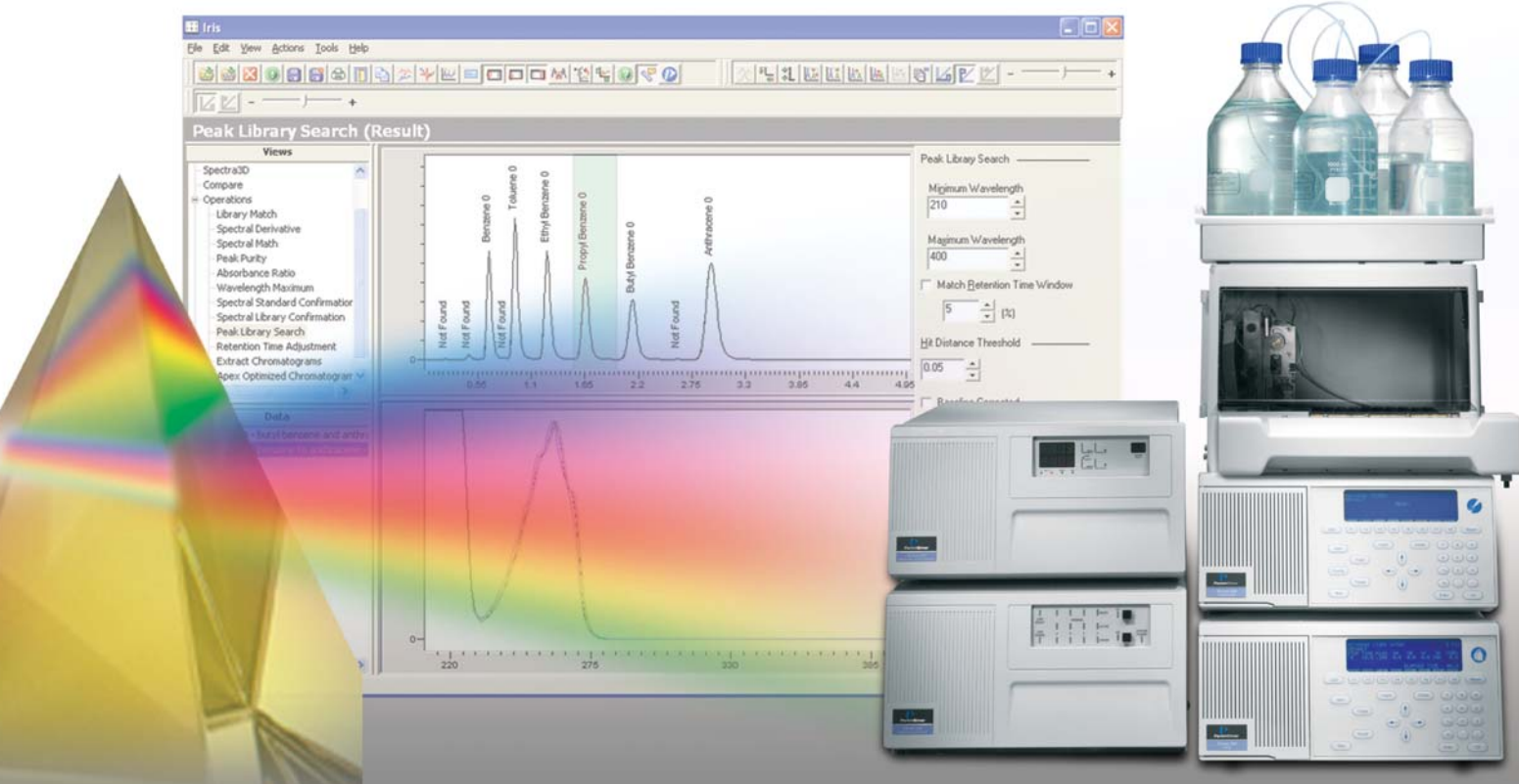



Rugged and easy-to-use – the Series 200 Refractive Index

The Series 200 Refractive Index (RI), with its deflection-type design, allows sensitive detection of these compounds with low noise and drift characteristics. This advanced detector features internal temperature control of the flow cell, offset adjustment, autozero, and auto-purge of the reference cell – all with easy keypad entry. An intuitive, built-in Graphical User Interface allows auto calibration and extended diagnostic plus visualization of the real time signal during and between runs. The Series 200 RI Detector is a highly stable and sensitive LC and GPC detector for use with compounds that do not have high absorption in the UV range, such as polymers, sugars, organic acids and triglycerides.



Combining sensitivity and specificity – the Series 200 Fluorimeter

The Series 200 Fluorescence Detector delivers the outstanding performance and reliability you’ve come to expect from PerkinElmer. Although retention time is the main tool for identification of analytes, the complexity of real world samples requires the confirmation of peak identity through additional qualitative information. The major benefit afforded by fluorescence detection is the inherent high sensitivity of the technique coupled with outstanding specificity – given that relatively few molecules natively fluoresce. Therefore, the specific excitation and emission wavelength profile aids in the characterization of individual components. The Series 200 Fluorimeter far exceeds common standards of sensitivity. It is a necessary tool for the most demanding environmental, life science and food safety applications.

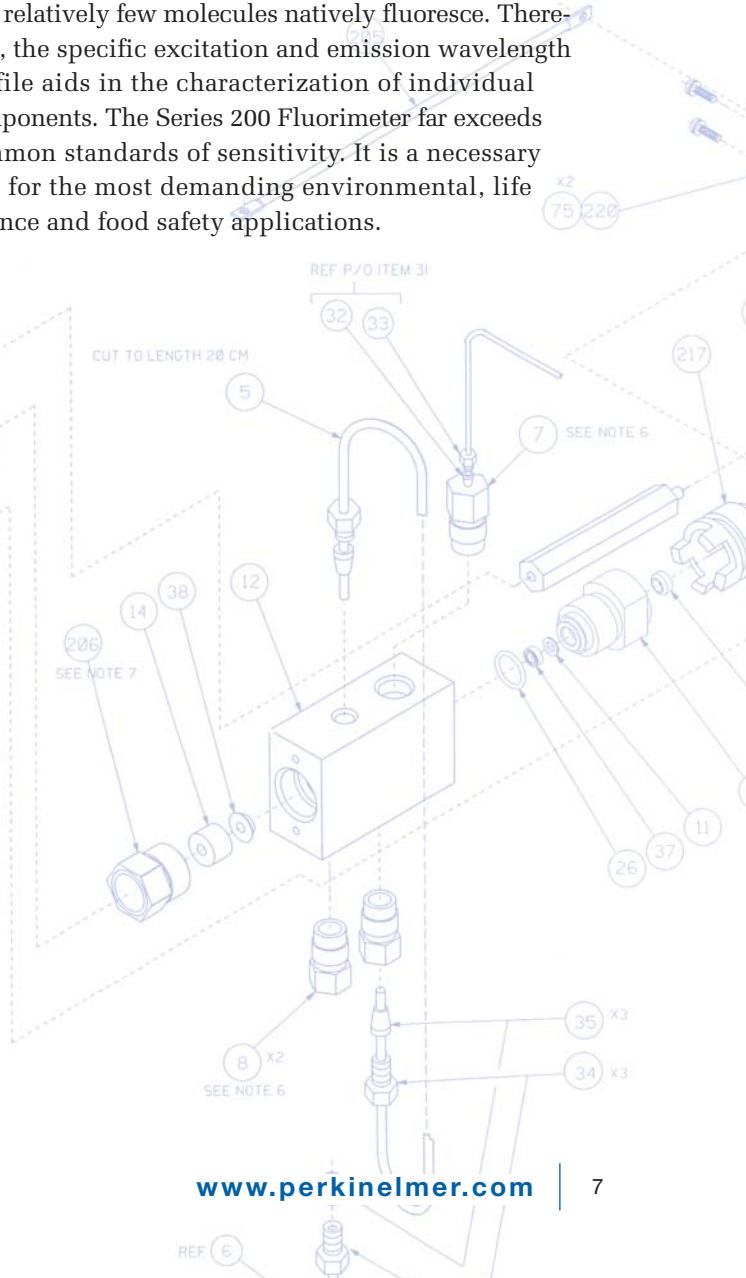
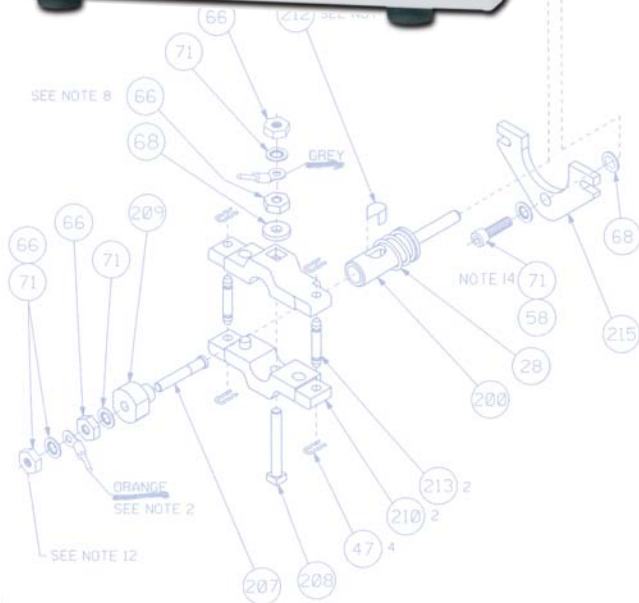

PerkinElmer, Inc.

There for the installation – and beyond.

The Series 200 HPLC modules and TotalChrom provide an integrated solution to your most demanding application requirements. From getting a new product to market to performing routine QA/QC analysis, the Series 200 HPLC systems powered by TotalChrom will help you to streamline your laboratory workflow. Best of all, PerkinElmer also has the know-how and resources to deliver best-in-class service from initial setup and installation to preventive maintenance.

Discover PerkinElmer's high-throughput instrumentation offerings: JANUS Automated Workstation

The JANUS™ Automated Workstation provides enhanced productivity and adaptability opportunities to meet the demanding needs of pharmaceutical, biotech and research customers. A scalable automated workstation, JANUS employs a modular design enabling the addition and replacement of liquid handling and labware movement technologies as application and throughput demands evolve.

JANUS is available in three platforms – Standard, Expanded and Integrator models. Each platform can be configured with a choice of pipetting modules to address throughput requirements and labware movement arms for walk-away capability. As application demands change, JANUS' modularity allows system upgrades accordingly. WinPREP® for JANUS application software provides the flexibility required for various laboratory applications without adding time-intensive programming complexity.

Expand your field of applications: discover the PerkinElmer's Radio-Flow detection technology: Radiomatic 150TR

The Radiomatic 150TR is a complete flow scintillation analyzer that is optimized for monitoring single- or dual-labeled radioisotopic samples separated by liquid chromatography. The Radiomatic 150TR detector platform uses state-of-the-art scintillation counting technology and can be used as a stand-alone detector with on-board chromatography data reduction or integrated into the Series 200 system.



JANUS Automated Workstation

PerkinElmer Life and
Analytical Sciences
710 Bridgeport Avenue
Shelton, CT 06484-4794 USA
Phone: (800) 762-4000 or
(+1) 203-925-4602
www.perkinelmer.com



For a complete listing of our global offices, visit www.perkinelmer.com/lasoffices

©2005 PerkinElmer, Inc. All rights reserved. The PerkinElmer logo and design are registered trademarks of PerkinElmer, Inc. dotLINK, IRIS, Janus and SoftLINK are trademarks and PerkinElmer, TotalChrom and WinPrep are registered trademarks of PerkinElmer, Inc. or its subsidiaries, in the United States and other countries. All other trademarks not owned by PerkinElmer, Inc. or its subsidiaries that are depicted herein are the property of their respective owners. PerkinElmer reserves the right to change this document at any time without notice and disclaims liability for editorial, pictorial or typographical errors.