

ProLine Process Mass Spectrometer

Fast and reliable multiport, multicomponent process analysis

Features and Benefits

- Lowest price-per-sample point
- Small and compact size
- Multipoint backup for other process analyzers
- Multiport, multicomponent analysis
- Automatic sample stream switching
- Exceptional reliability
- Real-time analysis
- Scan for unwanted sample components
- High sensitivity
- Self-diagnostics
- Economical and versatile general troubleshooting and development tool

Reactor 1202	
Nitrogen	76.478
Oxygen	17.109
Argon	1.859
CO2	4.554
RQ	1.015

Multicomponent analysis. Up to 32 components, 8 or 16 streams.

Affordable Process MS

Offering high performance without the high price, the ProLine Series of process mass spectrometers from AMETEK Process Instruments provides features and a level of performance associated with much more expensive mass spectrometer systems. At last, you can afford to use MS for applications currently using GC, NIR, FTIR or multiple single-component analytical devices.

Field-Proven Reliability

AMETEK has more than 20 years of experience in mass spectrometer design and manufacture, with many thousands of analyzers already operating reliably. The field-proven analyzer components, combined with AMETEK's more than 30 years' experience in the process analyzer business, means you can depend on ProLine to take care of your critical process control requirements.

Automatic Operation

Automatic calibration and verification maintains the performance of the analyzer and allows it to quantify the amount of gas species in multicomponent samples. Operation of the ProLine is fully automatic, providing unattended analysis of

process streams and calibration gases. External process parameters can be used to trigger events. User-definable data presentation lets you set up the displays and outputs for your application needs.

Multipoint, Multicomponent

Real-time process monitoring of up to 32 components is straightforward with ProLine's powerful easy-to-use software. Complex overlapping spectra are handled automatically. The ProLine provides data output directly in concentration units with high sample rate and data throughput.

Compact

Analyzer space is always at a premium. Instrumentation has become smaller, lighter, less expensive and better, and it has just happened to process mass spectrometers. The AMETEK ProLine will easily fit on a corner of your bench or workspace.

Modular, Easy-to-Service

The compact modular design of the ProLine sets a new standard in serviceability. The mass spectrometer electronics are contained in a single, easily replaced, plug-in unit. No electronic calibrations are necessary—the electronics unit will mate with any analyzer head. An inexpensive spare analyzer head and electronics unit can be kept on the shelf and easily exchanged by your own personnel on-site. There is no need for the expensive service contract typical of most process mass spectrometers. Self-diagnostics and automatic device event logging ensure GMP compliance. Modem support is available for additional factory diagnosis and troubleshooting.



The ProLine comes complete with multiport automatic valve switching, inlet manifold, and turbomolecular pumping package.

Applications

- Fermentation/bioreactor off-gas analysis
- Fuel cell research and development
- Catalytic reactions/temperature-programmed desorption
- Semiconductor process exhaust gas monitoring
- Bulk gas analysis
- Gas blending
- Glove box monitoring
- Pharmaceutical solvent drying
- Gas scrubber efficiency
- Ethylene/ethylene oxide production
- Synthesis gas
- R&D laboratories



Analyzer head and electronics unit.

High Performance Analyzer

At the heart of this versatile mass spectrometer is the proven AMETEK quadrupole mass filter coupled with a contaminant-resistant enclosed ion source. The ProLine shows unequalled, remarkably clean mass separation, and delivers outstanding sensitivity and stability across the whole mass range.

Specifications

Range: 1-100 AMU. Optional: 1-200 AMU, 1-300 AMU.

Sample Ports: 8- or 16-way stream selection manifold

Inlet Pressure: 2 to 20 PSIG (14 to 140 kPa); optional sub-atmospheric pressure

Accuracy: Better than 0.5% of measured value for argon in air

Outputs: RS-485, RS-232, optional 4-20mA

Detection Range: From 1 PPM to 100%

Power: 115/230 VAC, 50/60 Hz, 500W

PC Requirements: Pentium® equivalent, 600MHz or better, Windows 98, ME, NT, 2000 or XP

Enclosure: General purpose benchtop

Dimensions: 14 3/8" x 24" x 15 1/2" (36.5 cm. x 61 cm. x 39.37 cm.)

Weight: 80 lb. (36 kg.)

Multiport Sampling System

The multiport sampling system consists of 8 or 16 manifold-mounted valves and a capillary restriction in an enclosure heated to prevent condensation. The inlet arrangement is designed for fast clearing and offers the choice of continuous flush on any valve position. The sampling system can be configured for sampling gas pressures from 2 to 20 PSIG with an option available that allows sampling of sub-atmospheric pressure gases. Different calibration and analysis methods can be assigned to each sample port.

A constant pressure is maintained at the analyzer inlet using a fixed capillary in the sampling system. Sample and calibration gas streams can range from 0 to 20 PSIG.

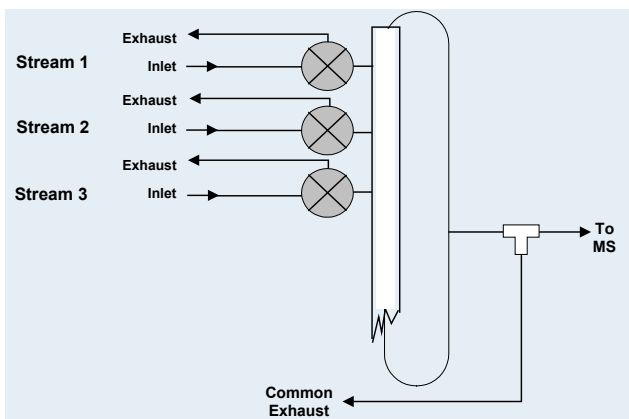

AMETEK®
PROCESS INSTRUMENTS

150 Freeport Road, Pittsburgh, PA 15238
Ph. +1-412-828-9040, Fax +1-412-826-0399
www.ametekpi.com



© 2006, by AMETEK, Inc.
All rights reserved. Printed in the U.S.A.
XXXX XX (12/06)

One of a family of innovative process analyzer solutions from AMETEK Process Instruments.
Specifications subject to change without notice.

SALES AND MANUFACTURING:

USA - Pennsylvania
150 Freeport Road, Pittsburgh, PA 15238 • Tel: +1-412-828-9040, Fax: +1-412-826-0399

USA - Delaware
455 Corporate Blvd., Newark DE 19702 • Tel: +1-302-456-4400, Fax: +1-302-456-4444

USA - Oklahoma
2001 N. Indianwood Ave., Broken Arrow OK 74012 • Tel: +1-918-250-7200, Fax: +1-918-459-0165

CANADA - Alberta
2876 Sunridge Way N.E., Calgary, AB T1Y 7H9 • Tel: +1-403-235-8400, Fax: +1-403-248-3550

WORLDWIDE SALES AND SERVICE LOCATIONS:

USA - Texas
Tel: +1-281-463-2820, Fax: +1-281-463-2701

CHINA
Beijing / Tel: 86 10 8526 2111, Fax: 86 10 8526 2141
Chengdu / Tel: 86 28 8675 8111, Fax: 86 28-8675 8141
Shanghai / Tel: 86 21 6426 7049, Fax: 86 21 6426 7054

FRANCE
Tel: 33 1 30 68 89 00, Fax: 33 1 30 68 89 99

GERMANY
Tel: 49 21 59 91 36 0, Fax: 49 21 59 91 3680

MIDDLE EAST - Dubai
Tel: 971 4 881 2052, Fax: 971 4 881 2053

SINGAPORE
Tel: 65 6484 2388, Fax: 65 6481 6588