



重庆川仪分析仪器有限公司
Chongqing Sichuan Instrument Analyzer Co., Ltd.

工业在线分析仪器

Industrial on-line analyzer



在线分析先锋

Pioneer of on-line analysis

质量安全卫士

Kavass of quality and safety

企业简介

Enterprise Introduction

重庆川仪分析仪器有限公司（简称重分公司）是中国著名的分析仪器制造商，隶属于重庆川仪总厂有限公司，高新技术企业。企业通过ISO9001:2000国际质量体系认证、ISO14001:2004国际环境管理体系认证。多项产品分别通过CE、核电1E、国家环保产品等认证。在分析仪器设计、制造和应用领域引领40余年。产品广泛应用于环保、建材、石化、冶金、轻工、电站、制药、军工、医药卫生及科研领域。

主要产品:

■ 气体分析仪器及其成套系统

包括PA200系列智能气体分析仪器、PA300Ex系列智能防爆气体分析仪器、BO2000模块化气体分析仪器，PA100系列气体分析仪器，以及PS6000系列过程分析成套系统，PS6400烟气连续监测系统。

■ 水质分析仪器及其成套系统

包括70X4通用系列、70X3本安防爆系列、LA7000智能系列、7061硅/磷酸根系列、7051钠离子、军工产品等分析仪器，以及WS2000系列汽水取样水质分析成套系统，WS3000系列水质连续监测成套系统。

■ 实验室分析仪器

包括SC-6000系列、SC-3000B系列、SC-2000系列、SC-200系列气相色谱仪，以及LC-900B高效液相色谱仪、色谱工作站等。

重分公司拥有深厚的科研开发实力，强大的工程应用队伍，专业化的用户服务体系，培养了一大批从事分析仪器及成套系统的开发、制造及应用技术专业人才，在同行业处于领先地位。重分公司一直秉承“川仪在用户身边，用户在川仪心中”，“以顾客为关注焦点，让顾客满意”的服务宗旨，用更新的技术、更好的服务与客户真诚合作，共谋发展。

Chongqing Sichuan Instrument Analyzer Co., Ltd. (hereinafter referred to as SIC Analytical), a daughter of Chongqing Sichuan Instrument Complex Co., Ltd., is one of the most famous analytical instrument manufacturers in China, and a high-technology enterprise certified by ISO9001:2000 international quality system and ISO14001:2004 international environment Management System. Several series products are certified as CE, nuclear power 1E, and national environmental protection product. For almost 40 years in China, SIC Analytical has owned the leadership in designing, manufacturing, and servicing various analytical instruments. SIC Analytical's products are widely applied in various industries, such as environmental protection, architecture materials, oil and chemical, metallurgy, power, pharmacy, armament, and medical sanitation and scientific research, etc.

Main products

■ Gas analyzer and its integrated systems

Including PA200 Intelligent gas analyzer, PA300Ex Intelligent flameproof gas analyzer, BO2000 module gas analyzer, PA100 gas analyzer, PS6000 process analysis system, PS6400 continuous monitoring system.

■ Liquid analyzers and integrated systems

Including 70X4 series universal analyzers, 70X3 series Intrinsic safety explosion-proof analyzers, LA7000 series smart analyzers, 7061 series silica/phosphorus analyzers, 7051 sodium ion analyzer, and WS2000 series steam sampling and analysis systems, WS3000 series continuous liquid analysis systems.

■ Laboratory instruments

Including gas chromatographs from SC-200, SC-2000, SC-3000B, to SC-6000, also including LC-900B liquid chromatograph and chromatograph workstations. SIC Analytical owns Sino-leadership in analytical business for her great strength in researching and developing, strong engineering application team, professional service system, and numbers of skilled technicians. SIC Analytical always insists on her service spirits as SIC at Customers' Side and Customers in SIC's Heart, focuses on and meets customers' needs. With newer technologies and better service, SIC Analytical will continue to cooperate sincerely with all customers and develop together.

目录

CONTENT

第一部分 BO2000模块化气体分析仪器 Section 1 BO2000 Modular gas analyzer	
BO2000模块化气体分析仪器	1
BO2000 Modular gas analyzer	
第二部分 PA200系列智能气体分析仪器 Section 2 PA200 Series intelligent gas analyzer	
1. PA200-GXH 智能红外线气体分析仪器	3
PA200-GXH Intelligent infrared gas analyzer	
2. PA200-GXH+O ₂ 智能气体分析仪器	6
PA200-GXH+O ₂ Intelligent gas analyzer	
3. PA200-GXH (II) +O ₂ 智能气体分析仪器	8
PA200-GXH (II) +O ₂ Intelligent gas analyzer	
4. PA200-CY智能磁压式氧分析仪器	10
PA200-CY Intelligent paramagnetic pressure oxygen analyzer	
5. PA200-CJ智能磁机械式氧分析仪器	12
PA200-CJ Intelligent paramagnetic mechanism oxygen analyzer	
6. PA200-DH智能微量氧分析仪器	14
PA200-DH Intelligent trace oxygen analyzer	
7. PA200-GT 智能氧分析仪器	16
PA200-GT Intelligent oxygen analyzer	
8. PA200-RQD智能热导气体分析仪器	18
PA200-RQD Intelligent thermal conductivity gas analyzer	
9. PA200-WS智能微量水分析仪器	20
PA200-WS Intelligent trace water analyzer	
第三部分 PA100系列气体分析仪器 Section 3 PA100 Series gas analyzer	
1. PA100-GXH红外线气体分析仪器	22
PA100-GXH Infrared gas analyzer	
2. PA100-CJ磁机械式氧分析仪器	25
PA100-CJ Paramagnetic mechanism oxygen analyzer	
3. PA100-RQD热导气体分析仪器	27
PA100-RQD Thermal conductivity gas analyzer	
第四部分 PA300Ex系列智能防爆气体分析仪器 Section 4 PA300Ex Series intelligent flameproof gas analyzer	
1. PA300-GXHEX 智能防爆红外线气体分析仪器	30
PA300-GXHEX Intelligent flameproof infrared gas analyzer	
2. PA300-CJEx智能防爆磁机械式氧分析仪器	32
PA300-CJEx Intelligent flameproof paramagnetic mechanism oxygen analyzer	
3. PA300-GTEx 智能防爆氧分析仪器	34
PA300-GTEx Intelligent flameproof oxygen analyzer	
4. PA300-RQDEx 智能防爆热导气体分析仪器	36
PA300-RQDEx Intelligent flameproof thermal conductivity gas analyzer	
第五部分 选型与应用 Section 5 Selection and application	
1. 分析仪器应用条件	39
Analyzer application condition	
2. 选型指南	40
Selection guides	
3. 典型业绩	42
Typical achievements	

BO2000

模块化气体分析仪器

BO2000 Modular gas analyzer



概述

BO2000 模块化气体分析仪器是采用模块化结构设计的多功能多组份的高性能在线过程分析仪器。仪器能连续自动测量、指示和记录流程中CO、CO₂、CH₄、SO₂、NO、NH₃、O₂、H₂、Ar等气体体积浓度。可同时监测显示4种以上气体体积浓度。仪器可用于石油、化工、化肥、空分、冶金、建材、电厂、轻工、制药、环保监测及科研等多种领域。

General description

BO2000 Modular gas analyzer based on state-of-art modular design, is a high performance multi-function and multi-component process gas analyzer. It can measure, indicate and record the volume concentration of up to six same or different gases in industrial process simultaneously, continuously and automatically, such as CO, CO₂, CH₄, SO₂, NO, NH₃, O₂, H₂, Ar, etc. It can be widely used in petroleum, chemical, fertilizer, air-separation, metallurgy, cement, light industry, pharmaceutical, environment monitoring, and scientific researching applications.

主要技术性能 Specifications

分析模块 Analyzer module	红外 Infrared	热导分析模块 Thermal conductivity	磁机械式氧 Magneto dynamic oxygen	固体传感器氧 Fuel-cell oxygen
被测对象 Measured components	CO, CO ₂ , CH ₄ , SO ₂ , NH ₃ , NO, etc.	H ₂ , Ar, CO ₂ , etc.	O ₂	O ₂
零点漂移 Zero drift	≤ ± 1%FS/7d	≤ ± 2%FS/24h	≤ ± 1%FS/1d	≤ ± 2%FS/3d
量程漂移 Span drift	≤ ± 1%FS/7d	≤ ± 2%FS/24h	≤ ± 1%FS/1d	≤ ± 2%FS/3d
线性误差 Linearity	≤ ± 1%FS	≤ ± 2%FS	≤ ± 1%FS	≤ ± 1%FS
重复性误差 Repeatability	Cv ≤ 0.5%	Cv ≤ 0.5%	Cv ≤ 1%	Cv ≤ 1%
预热时间 Preheated time	3h	3h	8h	3h
响应时间 Response time	T ₉₀ ≤ 10s	T ₉₀ ≤ 30s	T ₉₀ ≤ 30s	T ₉₀ ≤ 15s

仪器特点

- 模块化结构，有红外线分析模块、热导分析模块、固体传感器分析模块、磁机械式分析模块和中央控制单元模块。
- 标准19吋4U机箱，支持多种安装方式。机箱可安装分析模块与一个中央控制单元。一个机箱最多可安装2个分析模块（视模块种类而定）。同时测量6个组分（可以相同组分类型）。
- 中央控制单元通过CAN总线与分析模块相连，带中央控制单元的机箱与其它模块最远距离可达300m。
- 智能化模块类型识别，具有在线接入功能，无需关闭中央控制单元来增加新模块。
- 大屏幕LCD显示，可同时显示各组分测量值，分析仪状态等多种信息。
- 菜单内容丰富、操作简便、多级权限设置、安全性高。
- 历史测量数据及重要信息保存，并可随时查询。
- 使用膜状键盘，易于清洁擦洗。
- 通过菜单操作进行配置、功能测试、标定等。
- 带有丰富帮助信息。
- 多种信号输出接口，适合不同应用场合。
- 选配无线控制模块，利用专配智能手机可以实现无线超远程监控，包括实时数据监测。

Features

- Modular design, one central control unit with selectable modules of infrared, thermal conductivity, fuel-cell, magneto dynamic analyzer.
- Standard 19-inch 4U enclosure flexible for various assignments to measure up to six same or different components simultaneously. One analyzer module and one central control unit, or up to two analyzer modules in single housing, depending on the module kind.
- CAN bus connection between the central control unit and each analyzer module up to 300m.
- Analyzer module model auto-recognition, hot-plug without needing system turn-off for module additions.
- Large graphic LCD to display various information for measurement results, status, etc.
- Convenient operations with rich menus, high security with multi-level authorities.
- Historic measurement data and important information saved for inquiry any time.
- Tactile membrane key-pad for keeping clean easily.
- Assignments, function tests and calibration with menu operations.
- Rich help information
- Various outputs available for different applications
- Optional wireless control module, uses the special intelligent handset execution long-distance monitoring, including real-time data monitoring

外形尺寸 (mm) Outline dimension (mm)

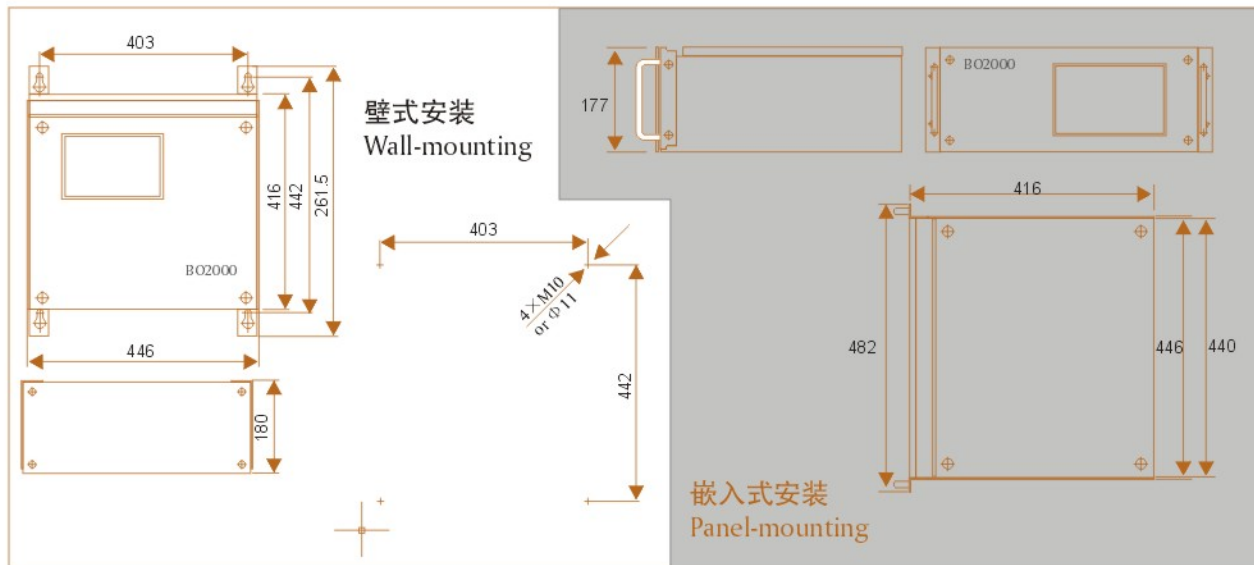

PA200-GXH

智能红外线气体分析仪器

PA200-GXH Intelligent infrared gas analyzer



概述

PA200-GXH 智能红外线气体分析仪器是采用不分光红外物理方法连续测量的工业用固定安装式仪器，是在引进德国哈特曼·布劳恩公司先进技术基础上开发的新一代在线分析器，能连续自动测量、指示、记录流程中CO、CO₂、CH₄、SO₂、NO、NH₃等被测气体的体积浓度。该仪器采用微机技术，对显示、测量、修正、输出等参数通过键盘进行设置或更改，以菜单形式操作，实现多种自动功能。仪器广泛用于石油、化工、化肥、空分、冶金、建材、电厂、轻工、制药、环保监测及科研等领域。

包括：

PA200-GXH智能红外线气体分析仪器；
PA200-GXH (A) 智能红外线气体分析仪器；
PA200-GXH (W) 智能红外线气体分析仪器。

工作原理

仪器基于不分光红外线吸收测量法，即非单元素气体(或蒸气)分子在2~12 μm红外线光谱范围内的选择性吸收原理工作。仪器由电子模块和分析模块组成。

General description

PA200-GXH Intelligent infrared gas analyzer is a newly developed product for continuous and automatic volume concentration measurements of various process gases, such as CO, CO₂, CH₄, SO₂, NO, NH₃, etc. It is based on state-of-art technology from Hartman · Braun with non-dispersive infrared physical-measurement method, and widely used in petroleum, chemical, fertilizer, air-separation, metallurgy, cement, power, light industry, pharmaceutical, environment monitoring, and scientific researching applications.

The specific type including

PA200-GXH Intelligent infrared gas analyzer,
PA200-GXH (A) Intelligent infrared gas analyzer,
PA200-GXH (W) Intelligent infrared gas analyzer.

Principles of operation

This analyzer is based on non-dispersive infrared absorption measurement method, that is, multi-element gas or vapour molecules features selective absorption in infrared spectrum from 2 μm to 12 μm. It is composed of an electronic module and an analysis module.

主要技术性能 Specifications

主要技术性能 Specifications	型号 Type	PA200-GXH	PA200-GXH (A)	PA200-GXH (W)
零点漂移 Zero drift		$\leq \pm 1\%FS/7d$	$\leq \pm 2\%FS/7d$	$\leq \pm 3\%FS/7d$
量程漂移 Span drift		$\leq \pm 1\%FS/7d$	$\leq \pm 2\%FS/7d$	$\leq \pm 3\%FS/7d$
重复性误差 Repeatability		$Cv \leq 0.5\%$	$Cv \leq 1\%$	$Cv \leq 1.5\%$
线性误差 Linearity		$\leq \pm 1\%FS$	$\leq \pm 2\%FS$	$\leq \pm 2\%FS$
预热时间 Preheated time		3h	3h	3h
响应时间 Response time		$\leq 10s$	$\leq 10s$	$\leq 20s$
输出信号 Output signals		0/4~20mA($R_L \leq 600\Omega$)	0/4~20mA($R_L \leq 600\Omega$)	0/4~20mA($R_L \leq 600\Omega$)

仪器特点

- 接收器恒温控制（软件完成控制），高稳定性红外光源，仪器稳定性好；
- 四气室结构接收器、窄带滤光片、软件运算，抗干扰能力强；
- 按键（零点、满度校准、线性校准、参数设置更改等）操作，灵活方便；
- 报警输出（上、下限值报警、温度报警、自检故障报警）；
- 重要工作电源自检；
- 大屏幕蓝屏显示，显示直观；
- 标准信号隔离输出(0/4~20mA)；
- 两档量程自动转换(量程转换1:2)；
- 测量气室镀金耐腐蚀；
- 仪器部件单元化，维护、检修方便；
- 特殊量程由用户与生产厂家技术部门协商；
- 自动校准功能(选配)PROFIBUS数字通讯(选配)；
- 标准19吋4U机箱，防护等级高(IP54)。

Features

- High stability with software-controlled thermostatical receiver and stable infrared lightsource.
- Excellent anti-interference capabilities with high sensitive four-chamber-structured individual receiver, narrowband filter and software algorithm.
- Flexible and convenient key-pad operations for calibrations of zero,span,linearity and for parameter settings or changes.
- Alarm outputs for upper and/or lower measurement, temperature, faulty by self-diagnostics.
- Important operating power self-check.
- Large size blue LCD for visual display.
- Standard isolated output signal of 0/4mA to 20mA.
- Auto-changed measuring range with ratio of 1:2.
- Corrosion-proof gold-plated measuring chamber.
- Parts unitization for convenient maintenance and overhauling.
- Please consult with the manufacturer for any special range.
- Optional PROFIBUS-DP function,optional automatic calibration function.
- Standard 19-inch 4U enclosure with high protection class (IP54).

测量对象及最小测量范围 Measured components and minimum ranges

序号 No.	测量对象 Measured Components	PA200-GXH 最小测量范围 Minimum measuring ranges	PA200-GXH(A) 最小测量范围 Minimum measuring ranges	PA200-GXH(W) 最小测量范围 Minimum measuring ranges
1	一氧化碳(CO)	0%~0.005% (50ppm)	0%~0.02% (200ppm)	/
2	二氧化碳(CO ₂)	0%~0.001% (10ppm)	0%~0.01% (100ppm)	0%~0.0005% (5ppm)
3	甲烷(CH ₄)	0%~0.005% (50ppm)	0%~0.02% (200ppm)	/
4	二氧化硫(SO ₂)	0%~0.03% (300ppm)	0%~0.05% (500ppm)	/
5	一氧化氮(NO)	0%~0.05% (500ppm)	0%~0.1% (1000ppm)	/
6	氨气 (NH ₃)	/	0%~0.1% (1000ppm)	/

标准量程范围 Standard measuring ranges

%VOL			
0~0.002	0~0.003	0~0.005	0~0.01
0~0.02	0~0.03	0~0.05	0~0.1
0~0.2	0~0.3	0~0.5	0~1
0~2	0~3	0~5	0~10
0~15	0~20	0~30	0~40
0~50	0~80	0~100	

注: (1)建议CO₂的量程范围上限最大为50%VOL;
(2)大于50%VOL 与生产厂设计部门商议。

Note: (1)For CO₂, the most upper limit of measuring range is 50%VOL.
(2)Above 50%VOL, please consult with the manufacturer.

气样条件 Sample conditions

序号 No.	影响量 Influence	额定工作范围 Ratings
1	气样温度 Temperature	5°C ~ 40°C
2	气样压力 Pressure	2kPa ~ 50kPa
3	气样流量 Flow	在30L/h ~ 60L/h内选择某一恒定值 A stable flow between 30L/h and 60L/h
4	含水量 Moisture	进入仪器前经干燥处理 Dried before entering
5	含尘量 Dust	灰尘和机械杂质除净 Free of dust and other mechanical impurities

PA200-GXH+O₂

智能气体分析仪器

PA200-GXH+O₂ Intelligent gas analyzer



概述

PA200-GXH+O₂ 智能气体分析仪器是采用不分光红外物理方法和电化学方法连续测量的工业用固定安装式仪器，仪器分别采用红外原理传感器和氧固体传感器，能连续自动测量、指示、记录流程中 CO、CO₂、CH₄、SO₂、NO、O₂ 等被测气体的体积浓度。该仪器采用微机技术，对显示、测量、修正、输出等参数通过键盘进行设置或更改，以菜单形式操作实现多种自动功能。仪器广泛用于石油、化工、化肥、空分、冶金、建材、电厂、轻工、制药、环保监测及科研等领域。

工作原理

仪器基于不分光红外线吸收测量法，即非单元素气体(或蒸气)分子在2~12 μm 红外线光谱范围内的选择性吸收原理工作和电化学原理测量氧方式工作。仪器由电子模块和分析模块组成。

主要技术性能 Specifications

测量组分 Measured component	CO, CO ₂ , CH ₄ , SO ₂ , NO, etc.
零点漂移 Zero drift	≤ ±1%FS/7d
量程漂移 Span drift	≤ ±1%FS/7d
重复性误差 Repeatability	Cv ≤ 0.5%
线性误差 Linearity	≤ ±1%FS
预热时间 Preheated time	3h
响应时间 Response time	≤ 10s
输出信号 Output signals	0/4~20mA (R _i ≤ 600 Ω)

氧组分 Oxygen	O ₂
零点漂移 Zero drift	≤ ±2%FS/3d
量程漂移 Span drift	≤ ±2%FS/3d
重复性误差 Repeatability	≤ ±1%
线性误差 Linearity	≤ ±1%FS
预热时间 Preheated time	3h
响应时间 Response time	≤ 20s
输出信号 Output signals	0/4~20mA (R _i ≤ 600 Ω)

General description

PA200-GXH+O₂ Intelligent gas analyzer is a fixed mounted analyzer, applying non-dispersive infrared physical-measurement method and electric-chemical method, which incorporates with a infrared sensor and a solid oxygen sensor, providing continuous and automatic volume concentration measurements of various process gases, such as O₂, and any one of CO, CO₂, CH₄, SO₂, NO, etc. This microprocessor-based analyzer features multiple automatic functions and menu-driven software for settings and changes of display, measurement, calibration, outputs by key-pad operations, and widely used in petroleum, chemical, fertilizer, air-separation, metallurgy, cement, power, light industry, pharmaceutical, environment monitoring and scientific researching applications.

Principles of operation

This analyzer is based on electric-chemical method and non-dispersive infrared absorption measurement method, that is, multi-element gas or vapour molecules features selective absorption in infrared spectrum from 2 μm to 12 μm. It is composed of a electronic module and analysis modules.

仪器特点

- 接收器恒温控制(软件完成控制), 高稳定性红外光源, 仪器稳定性好;
- 四气室结构接收器、窄带滤光片、软件运算、抗干扰能力强;
- 按键操作(零点、满度校准、线性校准、参数设置更改等), 操作灵活方便;
- 报警输出(上、下限极值报警、温度报警、自检故障报警);
- 可同时测量红外组分和氧的含量;
- 采用固体传感器测氧,免维护;
- 重要工作电源自检;
- 大屏幕蓝屏显示, 显示直观;
- 标准信号隔离输出(0/4 ~ 20mA);
- 标准19吋4U机箱, 防护等级高(IP54);
- 两档量程自动转换(量程转换1: 2);
- 测量气室镀金耐腐蚀;
- 仪器部件单元化, 维护、检修方便;
- 特殊量程由用户与生产厂家技术部门协商。

Features

- High stability with software-controlled thermostatical receiver and stable infrared light source.
- Excellent anti-interference capabilities with high sensitive four-chamber-structured individual receiver, narrowband filter and software algorithm.
- Flexible and convenient key-pad operations for calibrations of zero,span,linearity and for parameter settings or changes.
- Alarm outputs for upper and/or lower measurement, temperature, faulty by self-diagnostics.
- Available for oxygen and one of infrared measured components simultaneously.
- Maintenance-free solid oxygen sensor.
- Important operating power self-check.
- Large size blue LCD for visual display.
- Standard isolated output signal of 0/4mA to 20mA.
- Standard 19-inch 4U enclosure with high protection class (IP54).
- Auto-changed measuring range with ratio of 1:2.
- Corrosion-proof gold-plated measuring chamber.
- Parts unitization for convenient maintenance and overhauling.
- Please consult with the manufacturer for any special range.

测量对象及最小测量范围 Measured components and minimum ranges

序号 No.	测量对象 Measured components	最小测量范围 Minimum measuring ranges
1	一氧化碳 (CO)	0% ~ 0.005% (50ppm)
2	二氧化碳 (CO ₂)	0% ~ 0.002% (20ppm)
3	甲烷 (CH ₄)	0% ~ 0.005% (50ppm)
4	二氧化硫 (SO ₂)	0% ~ 0.01% (100ppm)
5	一氧化氮 (NO)	0% ~ 0.03% (300ppm)
6	氧气 (O ₂)	0% ~ 3%

气样条件 Sample conditions

序号 No.	影响量 Influence	额定工作范围 Ratings
1	气样温度 Temperature	5°C ~ 40°C
2	气样压力 Pressure	2kPa ~ 50kPa
3	气样流量 Flow	在30L/h ~ 60L/h内选择某一恒定值 A stable flow between 30L/h and 60L/h
4	含水量 Moisture	进入仪器前经干燥处理 Dried before entering
5	含尘量 Dust	灰尘和机械杂质除净 Free of dust and other mechanical impurities

PA200-GXH(II)+O₂

智能气体分析仪器

PA200-GXH (II) +O₂ Intelligent gas analyzer



概述

PA200-GXH (II) +O₂ 智能气体分析仪器是采用先进的不分光红外分析原理和电化学方法同时连续自动测量三种组分的工业用固定安装式仪器, 测量组分中一种为 O₂, 其它两种可以为 CO、CO₂、CH₄、SO₂、NO、NH₃ 中任意两种组合。该仪器采用微机技术, 通过大屏幕显示器, 以菜单操作方式对显示、测量、校正、输出、报警等参数进行设置或更改, 实现多种自动功能。该仪器应用范围广, 特别适宜环保监测分析领域使用。

General description

PA200-GXH (II) +O₂ Intelligent gas analyzer is an industrial fixed mounted product, which is based on state-of-art electric-chemical method and non-dispersive infrared absorption measurement method. It can measure simultaneously oxygen and any two of CO, CO₂, CH₄, SO₂, NO, NH₃. This microprocessor-based analyzer features multiple automatic functions and menu-driven software for settings and changes of display, measurement, calibration, outputs by key-pad operations through a large size LCD and is widely used in various applications, especially in environmental protection.

主要技术性能 Specifications

测量组分 Measured components	CO, SO ₂ , NO, CO ₂ , CH ₄ , NH ₃ , etc.
零点漂移 Zero drift	≤ ± 1%FS/7d
量程漂移 Span drift	≤ ± 1%FS/7d
线性误差 Linearity	≤ ± 1%FS
重复性 Repeatability	Cv ≤ 0.5%
响应时间 Response time	≤ 10s
预热时间 Preheated time	3h
输出信号 Output signals	0/4-20mA(R _L ≤ 600 Ω)

氧组分 Oxygen	O ₂
零点漂移 Zero drift	≤ ± 2%FS/3d
量程漂移 Span drift	≤ ± 2%FS/3d
线性误差 Linearity	≤ ± 1%FS
重复性 Repeatability	Cv ≤ 1%
响应时间 Response time	≤ 20s
预热时间 Preheated time	3h
输出信号 Output signals	0/4-20mA(R _L ≤ 600 Ω)

仪器特点

- 接收器恒温控制(软件完成控制), 高稳定性红外光源, 仪器稳定性好;
- 四气室结构接收器、窄带滤光片、软件运算, 抗干扰能力强;
- 按键(零点、满度校准、线性校准、参数设置更改等)操作, 灵活方便;
- 报警输出(上、下限极值报警、自检故障报警);
- 可同时测量2个红外组分和1个氧组分;
- 采用固体氧传感器, 免维护;
- 重要工作电源自检;
- 大屏幕蓝屏显示, 显示直观;
- 标准信号隔离输出 (0/4 ~ 20mA);
- 标准19吋4U机箱, 防护等级高 (IP54);
- 测量气室镀金耐腐蚀;
- 仪器部件单元化, 维护、检修方便;
- 特殊量程由用户与生产设计部门商议;

Features

- High stability with software-controlled thermostatical receiver and stable infrared light source.
- Excellent anti-interference capabilities with high sensitive four-chamber-structured individual receiver, narrowband filter and software algorithm.
- Flexible and convenient key-pad operations for calibrations of zero, span, linearity and for parameter settings or changes.
- Alarm outputs for upper and/or lower measurement, temperature, faulty by self-diagnostics.
- Available for oxygen and two of infrared measured components simultaneously.
- Maintenance-free solid oxygen sensor.
- Important operating power self-check.
- Large size blue LCD for visual display.
- Standard isolated output signal of 0/4mA to 20mA.
- Standard 19-inch 4U enclosure with high protection class(IP54).
- Corrosion-proof gold-plated measuring chamber.
- Parts unitization for convenient maintenance and overhauling.
- Please consult with the manufacturer for any special range.

测量对象及最小测量范围 Measured components and minimum ranges

序号 No.	测量对象 Measured components	最小测量范围 Minimum ranges
1	二氧化硫 SO ₂	0% - 0.01% (100ppm)
2	一氧化氮 NO	0% - 0.03% (300ppm)
3	氧气 O ₂	0% - 3%
4	二氧化碳 CO ₂	0% - 0.01% (100ppm)
5	一氧化碳 CO	0% - 0.02% (200ppm)
6	甲烷 CH ₄	0% - 0.02% (200ppm)
7	氨气 NH ₃	0% - 0.1% (1000ppm)

气样条件 Sample conditions

序号 No.	影响量 Influence	额定工作范围 Ratings
1	气样温度 Temperature	5°C ~ 40°C
2	气样压力 Pressure	2kPa ~ 50kPa
3	气样流量 Flow	在30L/h ~ 60L/h内选择某一恒定值 A stable flow between 30L/h and 60L/h
4	含水量 Moisture	进入仪器前经干燥处理 Dried before entering
5	含尘量 Dust	灰尘和机械杂质除净 Free of dust and other mechanical impurities

PA200-CY

智能磁压式氧分析仪器

PA200-CY Intelligent paramagnetic pressure oxygen analyzer



概述

PA200-CY智能磁压式氧分析仪器是采用物理方法连续测量的工业用固定安装式仪器，是在引进德国哈特曼·布劳恩公司先进技术基础上开发的新一代在线分析器，能连续自动测量、指示、记录流程中O₂的体积浓度。该仪器采用微机技术，对显示、测量、修正、输出等参数通过键盘进行设置或更改，以菜单形式操作，实现多种自动功能。仪器广泛用于石油、化工、空分、冶金、建材、轻工、环保监测及其他各种炉、窑或烟道中的氧的百分浓度分析。

工作原理

该仪器基于氧顺磁性的间接测量原理工作，检测元件是薄膜电容器，被分析气样和参比气样在膜片两侧产生压力差，转换成标准输出信号与分析气样中的氧浓度呈严格的线性关系。

主要技术性能 Specifications

零点漂移 Zero drift	$\leq \pm 1\%FS/7d$
量程漂移 Span drift	$\leq \pm 1\%FS/7d$
重复性误差 Repeatability	$Cv \leq 0.5\%$
线性误差 Linearity	$\leq \pm 1\%FS$
预热时间 Preheating time	3h
传感器响应时间 Response time	$\leq 2.5s$
输出信号 Output signals	0/4~20mA ($R_L \leq 600\Omega$)

General description

PA200-CY Intelligent paramagnetic pressure oxygen analyzer is a newly developed field-fixed product for continuous and automatic volume concentration measurement of oxygen in process, which is based on the state-of-art technology imported from Hartman&Braun with physical-measurement method. This microprocessor-based analyzer features multiple automatic functions and menu-driven software for settings and changes of display, measurement, calibration, outputs through key-pad operations. It is widely used for percent oxygen monitoring in petroleum, chemical, air-separation, metallurgy, cement, light industry, environment and various furnaces, kilns or flues applications.

Principles of operation

PA200-CY works on the basis of paramagnetism of oxygen. The key element of detector is a thin-film capacitor. With a reference gas and a sample gas, a differential pressure is formed across the capacitor. The pressure is then converted to an output signal, which is strictly proportional to oxygen in the sample.

仪器特点

- 仪器稳定性好，精度高；
- 按键操作(零点、满度校准、参数设置更改等)，操作灵活方便；
- 报警输出
(上、下限极值报警、温度报警、自检故障报警)；
软件完成工作运算，抗干扰能力强，重要工作电源自检；
- 大屏幕蓝屏显示，显示直观；
- 标准信号隔离输出(0/4 ~ 20mA)；
- 响应时间为同类氧分析器最短；
- 仪器部件单元化，维护、检修方便；
- 量程变化范围广，并可用于高氧的分析；
- 标准19吋4U机箱，防护等级高(IP54)；
- 抑制量程比最大可达100:1，最小量程：0 ~ 1%；
- 自动校准功能（选配）。

量程范围

最小量程:

0~1% O₂, 最大量程: 0~30% O₂, 可灵活设置抑制零位量程, 例如对应0~1% O₂ 量程, 可设置20~21% O₂ • 99~100% O₂。

Features

- High stability and high precision
- Flexible and convenient key-pad operations for zero, span calibrations and parameter settings or changes.
- Alarm outputs for upper and/or lower measurement, temperature, faulty by self-diagnostics.
Software engineering calculations, excellent anti-interference capabilities and self-diagnostics of critical power supplies.
- Large blue screen for visual display
- Standard isolated output signal from 0/4mA to 20mA.
- Fastest response time compared with similar products.
- Parts unitization for convenient maintenance and overhauling.
- Wide dynamic range, optimal solution for high purity oxygen analysis.
- Standard 19-inch 4U enclosure with high protection class(IP54).
- Suppression ratio up to 100:1 with minimum span to 1%.
- Optional automatic calibration function.

Measuring ranges

Minimum range:

0~1% O₂, maximum range 0~30% O₂. Zero-suppressed range is available, eg. 20~21% O₂ • 99~100% corresponding span of 1% O₂.

气样条件 Sample conditions

序号 No.	影响量 Influence	额定工作范围 Ratings
1	气样温度 Temperature	5°C ~ 40°C
2	气样压力 Pressure	0.2kPa ~ 50kPa
3	气样流量 Flow	在30L/h ~ 90L/h内选择某一恒定值 A stable flow between 30L/h and 90L/h
4	含水量 Moisture	进入仪器前经干燥处理 Dried before entering
5	含尘量 Dust	灰尘和机械杂质除净 Free of dust and other mechanical impurities

氧气纯度分析的首选仪器!
The best choice for oxygen purity analysis!

PA200-CJ

智能磁机械式氧分析仪器

PA200-CJ Intelligent paramagnetic mechanism oxygen analyzer



概述

PA200-CJ 智能磁机械式氧分析仪器是我公司开发的新一代在线分析仪器。仪器利用氧的强顺磁性原理和独特设计的传感器，采用自动零平衡控制方法，实现气体氧含量的快速、准确、连续测量，仪器可广泛应用于石油、化工、化肥、空分、冶金、水泥、医药及各种炉、窑烟道气的氧分析，是生产控制、节能降耗、提高产品质量、保证系统安全运行的可靠检测工具。

工作原理

该仪器基于氧气顺磁性的间接测量原理工作。在非均匀强磁场中悬挂有哑铃形磁敏元件，氧分子因强顺磁性被磁化改变磁场强度，产生一排斥力矩促使哑铃偏转，光电系统检测偏转角并转换成电信号。输出电流的信号正比于被测气样中的含量，且呈严格的线性关系。仪器有电流负反馈设计，以提高仪器性能。



原理图 Schematic diagram

General description

PA200-CJ Intelligent paramagnetic mechanism oxygen analyzer is a newly self-developed industrial product, which is based on the strong paramagnetism of oxygen. With a unique automatic null balance oxygen sensor, it provides a rapid, accurate, and continuous oxygen measurement. As a reliable tool for production control, saving energy and reducing consumption, promoting product quality and ensuring system safety, it is widely used in petroleum, chemical, air-separation, metallurgy, cement, light industry, environment and various furnaces, kilns or flues applications.

Principles of operation

PA200-CJ is based on the strong paramagnetism of oxygen. A dumbbell-shaped magnetic sensitive element is suspended in a non-uniform magnetic field. As oxygen molecules are magnetized to change the magnetic field density, the element is subjected to displacement forces, resulting in a displacement. A photoelectricity system is applied to detect this effect and converts it into an electrical signal, which is proportional and strictly linear to the measured oxygen. To improve performance, this analyzer also uses current feedback design.

主要技术性能 Specifications

显示 Display	蓝屏240×128点阵图形液晶显示器240×128 Pixels blue graphic LCD
量程 Measuring range	0-100%内任意选择, 最小跨度1% Selectable within 0-100%O ₂ , Minimum span 1% O ₂
零点漂移 Zero drift	≤ ± 1%FS/24h 或 0.05% O ₂ /24h, 取大者 ≤ ± 1%FS/24h or 0.05% O ₂ /24h, which is greater
量程漂移 Span drift	≤ ± 1%FS/24h 或 0.05% O ₂ /24h, 取大者 ≤ ± 1%FS/24h or 0.05% O ₂ /24h, which is greater
线性误差 Linearity	≤ ± 1%FS/24h 或 0.05% O ₂ /24h, 取大者 ≤ ± 1%FS/24h or 0.05% O ₂ /24h, which is greater
重复性 Repeatability	量程跨度大于10%时Cv≤1%, 反之Cv≤2% Cv≤1%, while the measuring range is greater than 10%, then otherwise Cv≤2%
输出波动 Output signals	≤0.05%FS 或 0.05% O ₂ , which is greater
预热时间 Preheated time	8h
响应时间 Response time	T ₉₀ ≤30s 流量12L/h while sample flow at 12L/h
输出信号 Output signals	隔离Isolated 0/4~20mA (R _L ≤600Ω)
报警输出 Alarm output	SPDT继电器, 报警参数、报警方式(上/下限)、报警点任意设置 SPDT relays upon selectable alarm parameters, mode(high/low), setpoints

仪器特点

- 独特的传感器设计, 精确恒温控制, 响应快、线性好、高稳定性;
- 微处理器、模拟/数字信号处理相结合, 测量准确;
- 大尺寸点阵LCD、中文菜单驱动软件, 信息丰富、直观、操作方便;
- 模块化设计, 自诊断功能, 维护简单;
- 报警输出
(上、下限极值报警、温度报警、自检故障报警)
- 19吋4U机箱, 防护等级高 (IP54)
- 自动校准功能 (选配)

Features

- Fast response, excellent linearity, and high stability with unique sensor design, precise constant temperature control.
- Accurate measurement with microprocessor-based analog and digital signal conditioning.
- Large size LCD and Chinese menu-driven software for visual detailed information display and easy operations.
- Modular design with self-diagnostics for easy maintenance.
- Alarm outputs for high and/or low measurement, temperature, faulty by self-diagnostics.
- Standard 19-inch 4U enclosure with high protection class (IP54).
- Optional automatic calibration function.

气样条件 Sample conditions

序号 No.	影响量 Influence	额定工作范围 Ratings
1	气样温度 Temperature	5℃ ~ 40℃
2	气样压力 Pressure	2kPa ~ 45kPa
3	气样流量 Flow	在12L/h内选择某一恒定值 A stable flow 12L/h
4	含水量 Moisture	进入仪器前经干燥处理 Dried before entering
5	含尘量 Dust	灰尘和机械杂质除净 Free of dust and other mechanical impurities

PA200-DH

智能微量氧分析仪器

PA200-DH Intelligent trace oxygen analyzer



概述

PA200-DH智能微量氧分析仪器采用了线性好、灵敏度高的固体电化学传感器，并采用单片微处理器完成数据处理显示、自检故障、标准信号隔离输出及通信接口等，该仪器性能可靠、维护量小、使用方便，是高新技术的微量氧分析仪器。仪器应用领域：空分、冶金及化工流程中微量氧的测量。

工作原理

仪器的传感器是一只由固体电解质和仅对氧敏感的Ag-Pb电极构成的碱性原电池，当样气中的氧分子通过渗透进入原电池时，在电极上产生如下反应：

银(Ag)阴极上： $O_2 + 2H_2O + 4e^- \rightarrow 4OH^-$

铅(Pb)阳极上： $2Pb + 2KOH + 4OH^- - 4e^- \rightarrow 2KHPbO_2$

若原电池的阴阳极形成闭合回路，则回路中有电流流过，其电流的大小随氧浓度的大小而变化，因此只要测得原电池回路中的电流值，即可知气样中的氧浓度值。

General description

PA200-DH Intelligent trace oxygen analyzer uses a good linearity, high sensitivity solid electro-chemical sensor. It applies microprocessor technologies to complete data processing, display, featuring self-diagnostic function, providing standard isolated output signal and communication interface. It is a high-tech trace oxygen analyzer with high reliability, little maintenance and is easy to use. It can widely be used in various processes, such air separation, metallurgy, chemical industry.

Principles of operation

The sensor involved in this analyzer is an alkali galvanic cell, which is composed of solid electrolytes and a Ag-Pb electrode sensitive only to oxygen. When oxygen molecules in the sample diffuse into the cell, reaction occurs on the electrode as follows.

Argentine (Ag) cathode: $O_2 + 2H_2O + 4e^- \rightarrow 4OH^-$

Plumbum (Pb) anode: $2Pb + 2KOH + 4OH^- - 4e^- \rightarrow 2KHPbO_2$

While the loop between the cathode and the anode is closed, an electric current occurs, which changes with oxygen. Then oxygen concentration is obtained by measuring this current.

主要技术性能 Specifications

漂移 Drift	$\leq 5\%FS/24h$
重复性误差 Repeatability	$Cv \leq 5\%$
输出波动 Output fluctuation	$\leq 3\%FS$
线性误差 Linearity	$\leq 5\%FS$
最小量程 Minimum range	0~10ppm
最大量程 Maximum range	0~200ppm
上升时间 Rising time (T_{10-90})	=4 min
下降时间 drop time (T_{90-10})	=4 min
输出信号 Output signals	0/4~20mA ($R_L \leq 600\Omega$)

仪器特点

- 固体传感器（俗称“燃料电池”），寿命约2年，无维护；
- 单片微处理器数据处理显示；
- 按键操作（校准、参数设置更改等），操作灵活方便；
- 报警输出（上、下限极值报警，自检故障报警）
- 大屏幕蓝屏显示，显示直观（中文显示）
- 标准信号隔离输出（0/4~20mA）
- 19吋4U机箱，防护等级高（IP54）
- 自动校准功能（选配）

Features

- Maintenance free solid sensor (fuel cell) with lifetime about 2 years.
- Microprocessorbased data processing technology.
- Flexible and convenient key-pad operations for calibration and parameter settings or changes.
- Alarm outputs for upper and/or lower measurement, temperature, faulty by self-diagnostics.
- Large blue screen for visual display.
- Standard isolated output signal from 0/4mA to 20mA.
- Standard 19-inch 4U enclosure with high protection class (IP54).
- Optional automatic calibration function.

气样条件 Sample conditions

序号 No.	影响量 Influence	额定工作范围 Ratings
1	气样温度 Temperature	5°C ~ 40°C
2	气样压力 Pressure	0.03MPa ~ 0.2MPa
3	气样流量 Flow	在12L/h内选择某一恒定值 A stable flow 12L/h
4	含水量 Moisture	进入仪器前经干燥处理 Dried before entering
5	含尘量 Dust	灰尘和机械杂质除净 Free of dust and other mechanical impurities

选型、订货注意事项

订货时注明产品型号、量程、背景气成份、取样点压力。

Ordering notes

When ordering, the product model, measuring range, carrier gas composition and sample pressure should be indicated.

PA200-GT

智能氧分析仪器

PA200-GT Intelligent oxygen analyzer



概述

PA200-GT智能氧分析仪器是采用现代高性能固态氧传感器的工业固定安装式分析仪器。仪器能连续自动测量、指示、记录流程气体O₂的百分浓度。采用微机技术，对显示、测量、修正、输出等参数通过键盘进行设置或更改，以菜单形式操作，实现多种自动功能。标准电流信号输出，适用于闭环调节或微机自控。仪器广泛应用于石油、化工、空分、冶炼、水泥、医药、环保、轻工及其它各种炉、窑、烟道的气体分析。

General description

PA200-GT Intelligent oxygen analyzer is a field-fixed industrial product, which uses a state-of-art high performance solid oxygen sensor to provide continuous and automatic oxygen concentration in process gas. This microprocessor-based analyzer features multiple automatic functions and menu-driven software for settings and changes of display, measurement, calibration, outputs through key-pad operations, and is widely used for percent oxygen monitoring in petroleum, chemical, air-separation, metallurgy, cement, light industry, environment and various furnaces, kilns or flues applications.

主要技术性能 Specifications

零点漂移 Zero shift	$\leq \pm 2\%FS/3d$
量程漂移 Span shift	$\leq \pm 2\%FS/3d$
重复性误差 Linear error	$Cv \leq 1\%$
线性误差 Repeatability	$\leq \pm 1\%FS$
预热时间 Preheated time	3h
响应时间 Respondent time	$\leq 45s$
测量范围 Measuring range	最小: 0~1% O ₂ , 最大: 0~100% O ₂ , 任意设定 Minimum: 0~1% O ₂ , Maximum: 0~100% O ₂

仪器特点

- 分析部分精确恒温控制，仪器稳定性好，线性高；
- 全新OEM进口固态传感器，采用世界最新纳米技术及高分子凝胶工艺；
- 传感器使用寿命长达5~10年，有很强的抗振动、压力、流量波动影响的性能；
- 仪器有更宽的应用领域(如碳氢化合物、酸性洋气)；
- 微机技术，模拟、数字信号处理结合，抗干扰能力强，测量准确；
- 单量程、双量程、量程转换比自由选用，双量程自动转换；
- 零点、满度校准、参数设置等按键操作，操作灵活方便；
- 数字、字符、图形大屏幕LCD蓝屏显示，显示美观；
- 隔离0/4~20mA标准信号输出， $R_L \leq 600 \Omega$
- 继电器报警输出，报警参数(组份/温度/故障)，报警方式(上、下限)、报警点任意设置；
- 标准19吋4U机箱，防护等级高(IP54)；
- 自动校准功能(选配)。

Features

- High stability through accurate thermostatic control for analysis unit.
- High performance OEM solid oxygen sensor based on the newest nanotechnology and polymer gels technology.
- Longer service life almost 5 to 10 years. Strong immunity to vibration, pressure flow fluctuation.
- Extended applications for hydrocarbon, acid gas, etc.
- Accurate measurement and high anti-interference with microprocessor-based analog and digital signal conditioning.
- Selectable single or dual ranges with various range ratio and auto- changover.
- Flexible and convenient key-pad operations for zero,span, linearity calibrations and parameter settings or changes.
- Large blue LCD for visual display.
- Standard isolated output signal from 0/4mA to 20mA, $R_L \leq 600 \Omega$
- Relay alarm outputs easy to set as upper and/or lower measurement, temperature, faulty by self-diagnostics.
- Standard 19-inch 4U enclosure with high protection class (IP54).
- Optional automatic calibration function.

气样条件 Sample conditions

序号 No.	影响量 Influence	额定工作范围 Ratings
1	气样温度 Temperature	5°C ~ 40°C
2	气样压力 Pressure	0.03MPa ~ 0.2MPa
3	气样流量 Flow	在12L/h内选择某一恒定值 A stable flow 12L/h
4	含水量 Moisture	进入仪器前经干燥处理 Dried before entering
5	含尘量 Dust	灰尘和机械杂质除净 Free of dust and other mechanical impurities

PA200-RQD

智能热导气体分析仪器

PA200-RQD Intelligent thermal conductivity analyzer



概述

PA200-RQD智能热导气体分析仪器是我公司开发的新一代在线智能化分析仪器。仪器能连续自动测量、指示、记录各流程气中的H₂、Ar、CO₂等气体的体积百分含量。仪器输出4~20mA电流信号和报警信号，可作为控制信号源参与闭环控制，或将输出信号作远距离传送，到集中控制室作记录指示。仪器广泛用于电厂、化肥、空分、化工、轻工、制药、环保、冶金等工程领域。

工作原理

该仪器基于不同气体成分热导率不同的物理原理工作，采用熔包玻璃的铂丝敏感元件组成特殊设计的低漂移不平衡电桥，电桥信号经电路处理后输出线性化的标准电流信号。

主要技术性能 Specifications

零点漂移 Zero drift	$\pm 2\%FS/24h$
量程漂移 Span range	$\pm 2\%FS/24h$
线性误差 Linearity	$\leq 2\%FS$
重复性误差 Repeatability	$Cv \leq 1\%$
输出波动 Output fluctuation	$\leq 1\%FS$
预热时间 Preheating time	3h
响应时间 Response time	$T_{90} \leq 30s$
输出信号 Output signals	0/4~20mA ($R_L \leq 600\Omega$)

General description

PA200-RQD Intelligent thermal conductivity analyzer is new generation of online gas analyzer. It can continuously perform automatic measurement and indication on the volume percentage concentration of various process gases, such as H₂, Ar and CO₂. It provides a 4-20mA standard signal and alarm signals, which may be used as control signal sources for closed-loop controls or be transmitted through a long distance to a central control room for recording or indicating. It is widely used in such applications as power plant, fertilizer, air-separation, chemical industry, light industry, pharmacy, environmental protection and metallurgy.

Principles of operation

PA200-RQD Intelligent thermal conductivity analyzer is generally on the basis of different gases with different thermal conduction capabilities. The sensor is a low drift unbalance bridge, which is made of glass-covered platinum sensitive elements. The signal from the bridge is conditioned by individual circuits to a standard linear output current signal.

仪器特点

- 独特的传感器设计, 精确恒温控制, 响应快、线性好、稳定性高;
- 微处理器、模拟/数字信号处理相结合, 测量准确; 大尺寸点阵LCD、中文菜单驱动软件, 信息丰富、直观、操作方便;
- 报警输出(上、下极限值报警、温度报警、自检故障报警);
- 模块化设计、自诊断功能, 维护简单;
- 标准19吋4U机箱, 防护等级高(IP54);
- 自动校准功能(选配)。

Features

- Fast response, excellent linearity, and high stability with unique sensor design, precise constant temperature control.
- Accurate measurement by microprocessor-based analog and digital signal conditioning.
- Visual detailed information display, and ease of operations via a large size LCD and Chinese menu-driven software.
- Alarm outputs for high and/or low measurement, temperature, faulty by self -diagnostics.
- Easy maintenance with modular design and self-diagnostics functions.
- Standard 19-inch 4U enclosure with high protection class (IP54).
- Optional automatic calibration function.

量程规格 Standard measuring ranges

背景气 Carrier gas	被测组份 Components	氢气(H ₂)			氩气(Ar)		二氧化碳(CO ₂)
		氮气(N ₂)	空气(Air)	氩气(Ar)	氧气(O ₂)	氮气(N ₂)	空气(Air)
量程 Range	Vol%						
序号 No.							
1		0-5	0-4	0-3	0-15	0-15	0-20
2		0-10	8-100	0-4	0-20	0-20	0-30
3		0-15		0-5	0-30	0-30	0-50
4		0-20		0-10	0-50	0-50	0-80
5		0-30		0-15	0-80	0-80	0-100
6		0-50		0-20	0-100	0-100	
7		0-80		0-30		80-100	
8		0-100		0-50			
9		30-80		0-80			
10		40-70		0-100			
11		50-80					

气样条件 Sample conditions

序号 No.	影响量 Influence	额定工作范围 Ratings
1	气样温度 Temperature	5°C ~ 40°C
2	气样压力 Pressure	0.6KPa ~ 20KPa
3	气样流量 Flow	在12L/h内选择某一恒定值 A stable flow 12L/h
4	含水量 Moisture	进入仪器前经干燥处理 Dried before entering
5	含尘量 Dust	灰尘和机械杂质除净 Free of dust and other mechanical impurities

PA200-WS

智能微量水分析仪器

PA200-WS Intelligent trace water analyzer



概述

PA200-WS 智能微量水分析仪器是基于露点测湿度原理开发的具有先进水平的气体中微量水检测仪器，广泛用于空气分离、石油、化工等领域，是环境监测、生物工程、医疗卫生等科研工作的可靠检测工具。

General description

PA200-WS Intelligent trace water analyzer is advanced analyzer instrument, which is based on the dew point measuring humidity method it widely used in petroleum, chemical, fertilizer, air-separation, metallurgy, cement, power, light industry, pharmaceutical, environment monitoring and scientific researching applications.

主要技术性能 Specifications

量程 Range	最小0~300PPM，最大0~1000PPM Minimum range: 0~300PPM Maximum range: 0~1000PPM
测量误差 Linearity	测量误差不大于满量程的±5% ≤ ±5%FS
仪器漂移 Drift	仪器连续运行，单点漂移满足一天不超过满量程的±2% ≤ ±2%FS/24h
输出波动 Output fluctuation	仪器的输出波动不大于满量程的±1% ≤ ±1%FS

气样条件 Sample conditions

序号 No.	影响量 Influence	额定工作范围 Ratings
1	气样温度 Temperature	5°C ~ 40°C
2	气样压力 Pressure	0.03MPa ~ 0.2MPa
3	气样流量 Flow	在60L/h ~ 180L/h内选择某一恒定值 A stable flow 60L/h ~ 180L/h
4	含水量 Moisture	进入仪器前经干燥处理 Dried before entering
5	含尘量 Dust	灰尘和机械杂质除净 Free of dust and other mechanical impurities

PA200系列现场使用条件 PA200 Series influence operating conditions

条件 Conditions	序号 No.	影响量 Influence	额定工作范围 Ratings
气候条件 Ambient	1	环境温度 Temperature	5°C ~ 40°C
	2	环境相对湿度 Relative humidity	≤ 85%
	3	大气压力 Atmospheric pressure	70kPa ~ 106kPa
	4	空气流速 Air-flow rate	≤ 0.5m/s
机械条件 Mechanica	1	工作位置 Operating position	仪器应水平放置 Placed horizontally
	2	机械振动和冲击 Vibration and shock	无强烈的振动和冲击 Without apparent mechanical vibration and shock
电源条件 Power supply	1	电源电压 Voltage	220V ± 22V
	2	电源频率 Frequency	50Hz ± 0.5Hz

PA200系列外形尺寸(mm) PA200 Series outline dimension(mm)

注：部分机箱尺寸以说明书为准。

Note: The housing has two kind of types, please read the product operation and select the mounting dimension.

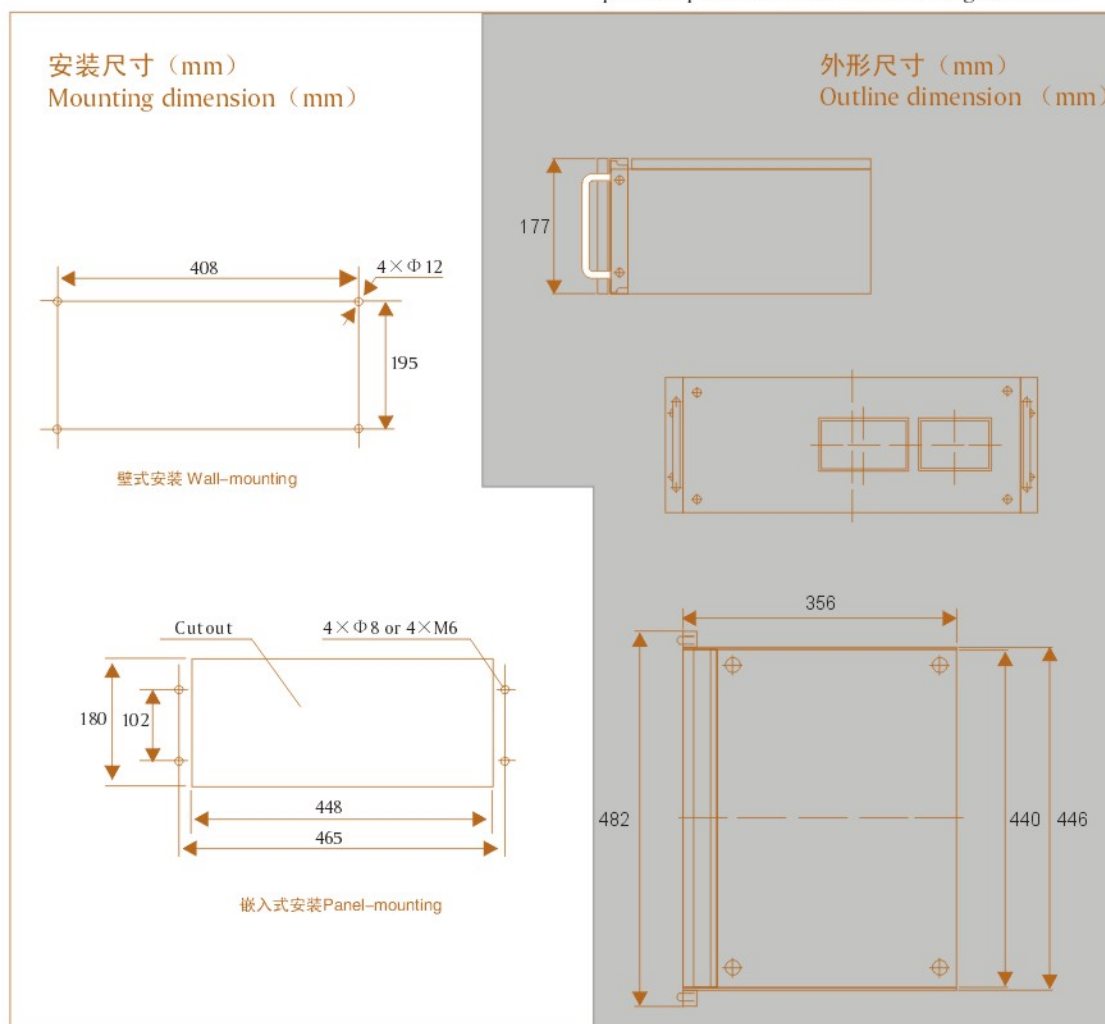

PA100-GXH

红外线气体分析仪器

PA100-GXH Infrared gas analyzer



概述

PA100-GXH 红外线气体分析仪器是采用物理方法连续测量的工业用固定安装式仪器,是在引进德国哈特曼布劳恩公司先进技术基础上开发的性价比重的在线分析器,能连接自动测量、指示、记录、流程中CO、CO₂、CH₄等测气体的体积浓度。仪器广泛用于石油、化工、化肥、空分、冶金、建材、电厂、轻工、制药、环保监测及科研等领域

工作原理

仪器基于不分光红外线吸收测量法,即非单元素气体(或蒸气)分子在2~12 μ m 红外线光谱范围内的选择性吸收原理工作。仪器由电子部件和分析部件组成。

General description

PA100-GXH Infrared gas analyzer is an industrial field-fixed analyzer with physical method. It is based on state-of-art technology from Hartman&Braun, and features high performance-cost for continuous and automatic volume concentration measurements of various process gases, such as CO, CO₂, CH₄, etc. It is widely used in petroleum, chemical, fertilizer, air-separation, metallurgy, cement, power, light industry, pharmaceutical, environment monitoring and scientific researching applications.

Principles of operation

This analyzer is composed of a electronic module and a analysis module, and based on non-dispersive infrared absorbtion measurement method, that is, multi-element gas or vapour molecules features selective absorbtion in infrared spectrum from 2 μ m to 12 μ m.

主要技术性能 Specifications

零点漂移 Zero drift	$\leq \pm 2\%FS/7d$
量程漂移 Span drift	$\leq \pm 2\%FS/7d$
重复性误差 Repeatability	$Cv \leq 1\%$
线性误差 Linearity	$\leq \pm 2\%FS$
预热时间 Preheating time	3h
响应时间 Response time	$\leq 10s$
输出信号 Output signals	0/4~20mA ($R_L \leq 600\Omega$) 0/2~10V ($R_L \leq 10k\Omega$)
测量组份 Measured Components	CO, CO ₂ , CH ₄ , etc.
最小量程 Minimum range	CO ₂ 0~100ppm CO/CH ₄ 0~200ppm

仪器特点

- 高稳定性红外光源，稳定性好；
- 前后气室结构接收器，搞干扰能力强；
- 接收器采用温度补偿，结构简单；
- 标准信号隔离输出（0/4~20mA）；
- 报警输出（上、下限极值报警）；
- 测量气室镀金耐腐蚀；
- 仪器部件单元化，维护、检修方便；
- 标准19吋机箱，防护等级高（IP54）。

Features

- High stability with highly reliable infrared light source .
- High anti-interference capability with a receiver made of front and back chambers.
- Simplified structure with a temperature-compasted receiver.
- Standard isolated output signal from 0/4mA to 20mA.
- Alarm outputs for upper and/or lower measurement.
- Corrosion-proof gold-plated measuring chamber.
- Parts unitization for convenient maintenance and overhauling.
- Standard 19-inch 4U enclosure with high protection class (IP54).

气样条件 Sample conditions

序号 No.	影响量 Influence	额定工作范围 Ratings
1	气样温度 Temperature	5°C ~ 40°C
2	气样压力 Pressure	2kPa~50kPa
3	气样流量 Flow	在30L/h ~ 60L/h内选择某一恒定值 A stable flow 30L/h ~ 60L/h
4	含水量 Moisture	进入仪器前经干燥处理 Dried before entering
5	含尘量 Dust	灰尘和机械杂质除净 Free of dust and other mechanical impurities

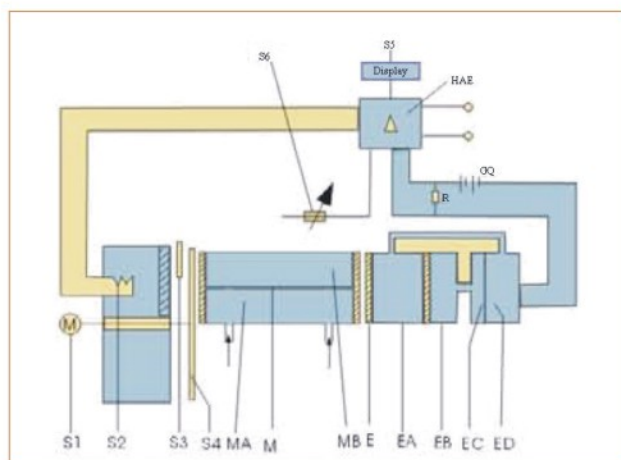

S1 切光马达 Slicing-light motor	EA 接受器室的前室 The front chamber of the receiver
S4 切光片 Slicing-light sheet	ED 薄膜电容定极 The fixed pole for the thin-film capacitor
M 测量室 Measuring cell	HAE 供电电源和信号放大处理部分 Supply power and signal-processing circuit
E 接收器 Receiver	S3 遮光片 Light barrier
EC 薄膜电容器动极 The metallic film for the thin-film capacitor (movable pole)	S6 热敏电阻 Thermistor
GQ 直流电压源 DC voltage source	MB 测量池参比气室 Reference gas chamber
S5 显示器 Display	EB 高阻抗电阻 The back chamber of the receiver
MA 测量池的分析气室 Analytical gas chamber	R 高阻抗电阻 High impedance resistance

PA100-CJ

磁机械式氧分析仪器

PA100-CJ Paramagnetic mechanism oxygen analyzer



概述

PA100-CJ磁机械式氧分析仪器是我公司新开发的在线分析仪器。仪器利用氧的强顺磁性和独特设计的传感器，采用自动零平衡控制方法，实现气体氧含量的快速、准确、连续测量；仪器可广泛应用于石油、化工、化肥、空分、冶金、建材、医药及各种炉、窑烟道气的氧分析，是生产控制、节能降耗、提高产品质量、保证系统安全运行的可靠检测工具。

工作原理

该仪器基于氧气顺磁性的间接测量原理工作。在非均匀强磁场中悬挂有哑铃形磁敏元件，氧分子因强顺磁化改变磁场强度，产生一排斥力矩促使哑铃偏转，光电系统检测偏转角并转换成电信号，且呈严格的线性关系。仪器有电流负反馈设计，以提高仪器性能。

General description

PA100-CJ Paramagnetic mechanism oxygen analyzer is a newly self-developed industrial product, which is based on the strong paramagnetism of oxygen. With a unique automatic null balance oxygen sensor, it provides a rapid, accurate, and continuous oxygen measurement. As a reliable tool for controlling production, saving energy and reducing consumption, promoting product quality, and ensuring system safety, it is widely used in petroleum, chemical, air-separation, metallurgy, cement, light industry, environment and various furnaces, kilns or flues applications.

Principles of operation

PA100-CJ is based on the strong paramagnetism of oxygen. A dumbbell-shaped magnetic sensitive element is suspended in a non-uniform magnetic field. As oxygen molecules are magnetized to change the magnetic field density, the element are subjected to displacement forces, resulting in a displacement. A photoelectricity system is applied to detect this effect and converts it into an electrical signal, which is proportional and strictly linear to the measured oxygen. To improve performance, this analyzer also uses current feedback design.

主要技术性能 Specifications

量程 RangeIn	最小Minimum: 0~1%, 最大Maximum: 0~100%
零点漂移 Zero drift	$\leq \pm 2\%FS/24h$ 或 $0.05\% O_2/24h$, 取大者which is greater
量程漂移 Span drift	$\leq \pm 2\%FS/24h$ 或 $0.05\% O_2/24h$, 取大者which is greater
线性误差 Linearity	$\leq \pm 2\%FS/24h$ 或 $0.05\% O_2/24h$, 取大者which is greater
重复性 Repeatability	量程跨度大于10%时 $Cv \leq 1\%$, 反之 $Cv \leq 2\%$ The measuring range is bigger than 10% ,then $Cv=1\%$, otherwise $Cv=2\%$
预热时间 Preheating time	8h
响应时间 Response time	$T_{90} \leq 30s$ (流量flow 12L/h)
输出信号 Output signals	0/4~20mA ($R_L \leq 600\Omega$) 0/2~10V ($R_L \geq 10K\Omega$)
报警输出 Alarm output	SPDT继电器, 报警参数、报警方式(上/下限)、报警点任意设置 SPDT relays upon selectable alarm parameters, mode(high/low), setpoints

仪器特点

- 独特的传感器设计, 恒温控制, 响应快、线性好、稳定性高;
- 报警输出(上、下限极值报警);
- 气样流量影响小;
- 操作维护简便;
- 标准19吋机箱, 防护等级高(IP54);

Features

- Fast response, excellent linearity, and high stability with unique sensor design and precise constant temperature control.
- Alarm outputs for high and/or low measurement
- Reduced flow influence.
- Easy operations and maintenance
- Standard 19-inch 4U enclosure with high protection class (IP54).

气样条件 Sample conditions

序号 No.	影响量 Influence	额定工作范围 Ratings
1	气样温度 Temperature	5°C ~ 40°C
2	气样压力 Pressure	2kPa ~ 45kPa
3	气样流量 Flow	在12L/h内选择某一恒定值 A stable flow 12L/h
4	含水量 Moisture	进入仪器前经干燥处理 Dried before entering
5	含尘量 Dust	灰尘和机械杂质除净 Free of dust and other mechanical impurities

PA100-RQD

热导气体分析仪器

PA100-RQD Thermal conductivity analyzer



概述

PA100-RQD热导气体分析仪器是我公司新开发的在线分析仪器。仪器能连接自动测量、指示各流程气中的 H_2 、Ar、 CO_2 等气体的体积百分含量。仪器输出4~20mA电流信号，可作为控制信号源参与闭环控制，或将输出信号作远距离传送，到集中控制室记录指示。仪器可广泛用于电站、化肥、空分、冶金等工程领域

工作原理

该仪器基于不同气体成分热导率不同的物理原理工作，采用熔包玻璃的铂丝敏感元件组成特殊设计的低漂移不平衡电桥，电桥信号以电路处理后输出线性的标准电流信号。

General description

PA100-RQD Thermal conductivity analyzer is an online product. It can continuously perform automatic measurement and indication on the volume percentage concentration of various process gases, such as H_2 , Ar and CO_2 . It provides a 4-20mA standard signal and alarm signals, which may be used as control signal sources for closed-loop controls or be transmitted through a long distance to a central control room for recording or indicating. It is widely used in such applications as power plant, fertilizer, air separation and metallurgy, etc.

Principles of operation

PA100-RQD Thermal conductivity analyzer is generally on the basis of different gases with different thermal conduction capabilities. The sensor is a low drift unbalance bridge, which is made of glass-covered platinum sensitive elements. The signal from the bridge is conditioned by individual circuits to a standard linear output current signal.

主要技术性能 Specifications

零点漂移 Zero drift	$\leq \pm 2\%FS/24h$
量程漂移 Span range	$\leq \pm 2\%FS/24h$
线性误差 Linearity	$\leq \pm 2\%FS$
重复性误差 Repeatability	$Cv \leq 1\%$
输出波动 Output fluctuation	$\leq 1\%FS$
预热时间 Preheating time	$T_{90} \leq 30s$
输出信号 Output signals	0/4~20mA ($R_L \leq 600\Omega$) 0/2~10V

量程规格 Standard measuring ranges

Range Vol%	背景气 Carrier gas	被测组份 Components	氢气(H ₂)			氩气(Ar)		二氧化碳(CO ₂)
			氮气(N ₂)	空气(Air)	氩气(Ar)	氧气(O ₂)	氮气(N ₂)	空气(Air)
序号 No.								
1			0-5/100	0-4/100	0-3/100	0-15/100	0-15/100	0-20/100
2			30-80		80-100			
3			40-70					
4			50-80					
5			80-100					

气样条件 Sample conditions

序号 No.	影响量 Influence	额定工作范围 Ratings
1	气样温度 Temperature	5°C ~ 40°C
2	气样压力 Pressure	0.6kPa~20kPa
3	气样流量 Flow	在12L/h内选择某一恒定值 A stable flow 12L/h
4	含水量 Moisture	进入仪器前经干燥处理 Dried before entering
5	含尘量 Dust	灰尘和机械杂质除净 Free of dust and other mechanical impurities

PA100系列现场使用条件 PA100 Series influence operating conditions

条件 Conditions	序号 No.	影响量 Influence	额定工作范围 Ratings
气候条件 Ambient	1	环境温度 Temperature	5°C ~ 40°C
	2	环境相对湿度 Relative humidity	≤85%
	3	大气压力 Atmospheric pressure	70kPa ~ 106kPa
	4	空气流速 Air-flow rate	≤0.5m/s
机械条件 Mechanica	1	工作位置 Operating position	仪器应水平放置 Placed horizontally
	2	机械振动和冲击 Vibration and shock	无强烈的振动和冲击 Without apparent mechanical vibration and shock
电源条件 Power supply	1	电源电压 Voltage	220V ± 22V
	2	电源频率 Frequency	50Hz ± 0.5Hz

PA100系列外形尺寸(mm) PA100 Series outline dimension(mm)

注：部分机箱尺寸以说明书为准。

Note: The housing has two kind of types, please read the product operation and select the mounting dimension.

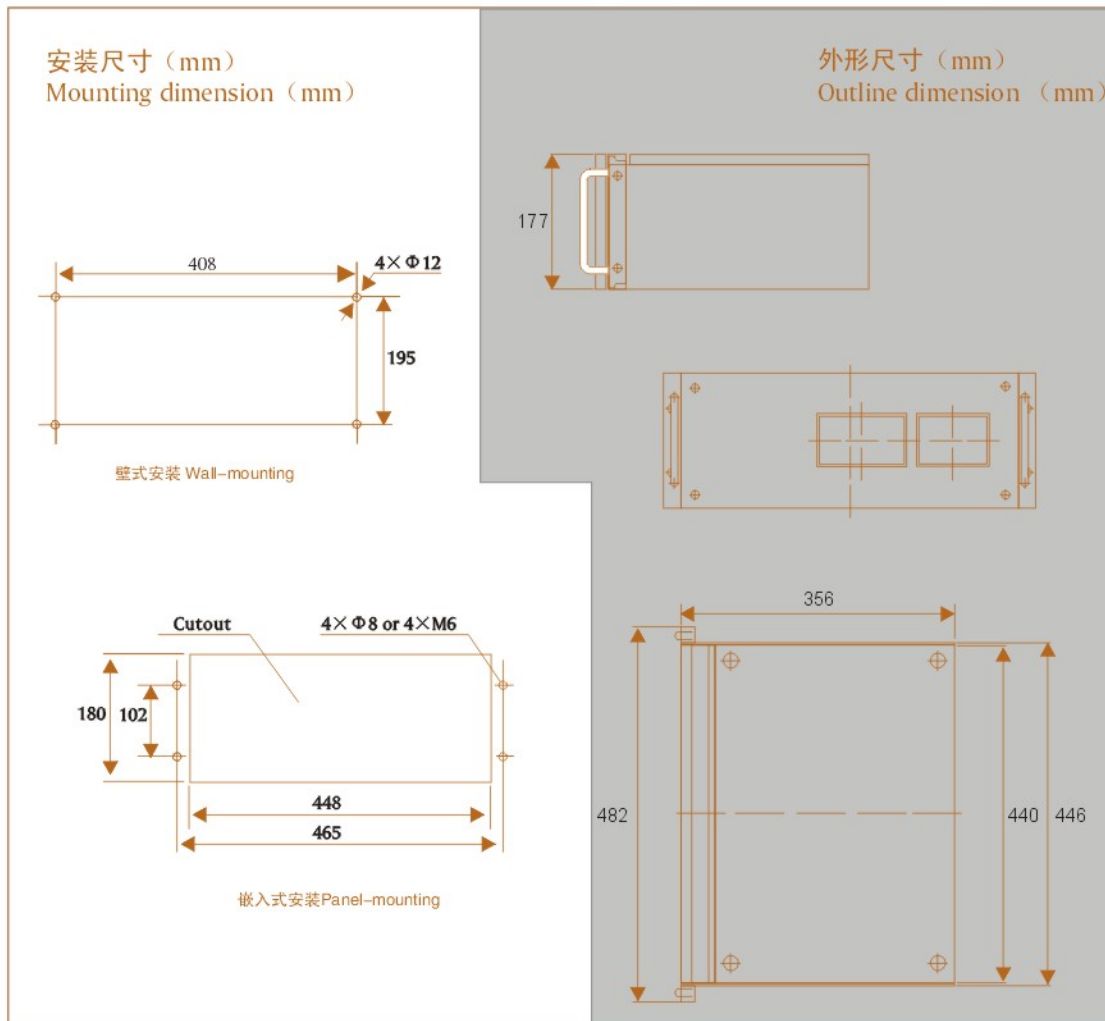

PA300 – GXHEX

智能隔爆红外线气体分析仪器

PA300-GXH Ex Intelligent flameproof infrared gas analyzer



概述

PA300 – GXHEX 智能隔爆红外线气体分析仪器是采用物理方法连续测量的工业用固定安装式仪器，是为了适应各种复杂的恶劣环境而开发的新一代隔爆型在线分析器，属于PA300Ex系列智能隔爆产品，仪器能连续自动测量、指示、记录流程气中的体积浓度。仪器用于有爆炸性危险的1区、2区环境的石油、化工、冶炼、建材、轻工及其它各种炉、窑或烟道等领域的气体分析。

General description

PA300-GXHEX Intelligent flameproof infrared gas analyzer, as an industrial field-fixed product for continuous and automatic volume concentration measurement of various process gases, is one of PA300Ex series new generation intelligent flame-proof instruments developed for harsh environment. It is quite suitable for gas analysis in zone 1 and zone 2 explosion hazard areas of petroleum, chemical, metallurgy, cement, light industry, pharmaceutical and various furnaces, kilns or flues.

主要技术性能 Specifications

零点漂移 Zero-point drift	$\leq \pm 1\%FS/7d$
量程漂移 Span drift	$\leq \pm 1\%FS/7d$
线性误差 Linearity	$\leq \pm 1\%FS$
重复性误差 Repeatability	$Cv \leq 0.5\%$
响应时间 Response time	$\leq 10s$
预热时间 Preheating time	3h
输出信号 Output signals	0/4~20mA ($R_L \leq 600\Omega$)
测量组份 Measured Components	CO, CO ₂ , CH ₄ , NH ₃ , etc.
防爆等级 Flameproof rankd	d II CT6

仪器特点

- 防爆等级高, 适用于有爆炸性危险的1区、2区, 防爆等级: d IIC T6
- 仪器信号及功能的智能化数字处理技术(零点、满度校准、线性校准、参数设置更改等), 感应键盘, 操作灵活方便;
- 接收器恒温控制(软件完成控制), 高稳定性红外光源, 仪器稳定性好;
- 大尺寸点阵LCD、中文菜单驱动软件, 信息丰富、直观、操作方便;
- 四气室结构接收器、窄带滤光片、软件运算, 抗干扰能力强;
- 报警输出(上、下限极值报警、温度报警、自检故障报警);
- 测量范围宽:
0~100ppm(CO₂), 0~200ppm(CH₄),
0~500ppm(NH₃), 0~200ppm(CO)
- 重要工作电源自检;
- 标准信号隔离输出(0/4~20mA)
- 两挡量程自动转换(量程转换1:2);
- 测量气室镀金耐腐蚀;
- 仪器部件单元化, 维护、检修方便;
- 特殊量程由用户与生产厂技术部门协商。

Features

- High explosion-proof class (d IIC T6), suitable for Zone 1 and Zone 2 explosion hazard areas.
- Intelligent digital signal processing techniques, simplified and easy touch keys operations for calibrations of zero, span, linearity, and for parameter settings or changes.
- High stability with software-controlled thermostatical receiver and stable infrared light source.
- Visual detailed information display, and easy operations with large size LCD and Chinese menu-driven software .
- Excellent anti-interference capabilities with highly sensitive four-chamber-structured individual receiver, narrowband filter, and software algorithm.
- Alarm outputs for upper and/or lower measurement, temperature, faulty by self-diagnostics.
- Wide measuring range: 0~100 ppm(CO₂), 0~200 ppm(CH₄), 0~500 ppm(NH₃), 0~200 ppm(CO)
- Important operating power self-check.
- Standard isolated output signal from 0/4mA to 20mA
- Auto-changed measuring range with ratio of 1:2;
- Corrosion-proof gold-plated measuring chamber
- Parts unitization for convenient maintenance and overhauling
- Special range available on consultation with the manufacturer.

气样条件 Sample conditions

序号 No.	影响量 Influence	额定工作范围 Ratings
1	气样温度 Temperature	5°C~40°C
2	气样压力 Pressure	2kPa~50kPa
3	气样流量 Flow	在30L/h~60L/h内选择某一恒定值 A stable flow 30L/h and 60L/h
4	含水量 Moisture	进入仪器前经干燥处理 Dried before entering
5	含尘量 Dust	灰尘和机械杂质除净 Free of dust and other mechanical impurities

PA300-CJEx

智能隔爆磁机械式氧分析仪器

PA300-CJEx Intelligent flameproof paramagnetic mechanism oxygen analyzer



概述

PA300-CJEx智能隔爆磁机械式氧分析仪器是采用物理方法连续测量的工业用固定安装式仪器，是为了适应各种复杂的恶劣环境而开发的新一代隔爆型在线分析器，属于PA300Ex系列智能隔爆产品，仪器能连续自动测量、指示、记录流程气中氧气的体积浓度。仪器采用微机技术，以菜单形式操作，实现多种自动功能。仪器用于有爆炸性危险的1区、2区环境的石油、化工、冶炼、建材、轻工及其它各种炉、窑或烟道等领域的氧气浓度分析。

General description

PA300-CJEx Intelligent flameproof paramagnetic mechanism oxygen analyzer, as an industrial field-fixed product for continuous and automatic oxygen volume concentration measurement in various process gases, is one of PA300Ex series new generation intelligent flame-proof instruments developed for harsh environment. This microprocessor-based analyzer features multiple automatic functions and menu-driven software operations. It is quite suitable for oxygen analysis in zone 1 and zone 2 explosion hazard areas of petroleum, chemical, metallurgy, cement, light industry, pharmaceutical, and various furnaces, kilns or flues.

主要技术性能 Specifications

显示 Display	蓝屏240X128点阵图形液晶显示器 240X128 LCD screen
零点漂移 Zero drift	$\leq 1\%FS/24h$ 或 $0.05\% O_2/24h$, 取大者 $\leq 1\%FS/24h$ or $0.05\% O_2/24h$, which is greater
量程漂移 Span drift	$\leq 1\%FS/24h$ 或 $0.05\% O_2/24h$, 取大者 $\leq 1\%FS/24h$ or $0.05\% O_2/24h$, which is greater
线性误差 Linearity	$\leq 1\%FS/24h$ 或 $0.05\% O_2/24h$, 取大者 $\leq 1\%FS/24h$ or $0.05\% O_2/24h$, which is greater
重复性误差 Repeatability	量程跨度大于10%时 $Cv \leq 1\%$, 反之 $Cv \leq 2\%$ $Cv \leq 1\%$ while range is greater than 10%. otherwise $Cv \leq 2\%$
输出波动 Output fluctuation	$\leq 0.5\%FS$ 或 $0.05\% O_2$, 取大者. $\leq 0.5\%FS$ or $0.05\% O_2$, which is greater.
预热时间 Preheated time	8h
响应时间 Response time	$T_{90} \leq 30s$ (12L/h)
输出信号 Output signals	隔离 Isolated 0/4~20mA ($R_L \leq 600 \Omega$)
报警输出 Alarm output	SPDT继电器, 报警参数, 报警方式(上、下限), 报警点任意设置 SPDT relays upon selectable alarm parameters, mode(high/low), setpoints

仪器特点

- 防爆等级高, 适用于有爆炸性危险的1区、2区, 防爆等级: d II CT6
- 仪器信号及功能的智能化数字处理技术(零点、满度校准、参数设置更改等), 感应键盘, 操作灵活方便;
- 独特的传感器设计, 精确恒温控制, 响应快、线性好、高稳定性;
- 微处理器、模拟/数字信号处理相结合, 测量准确;
- 大尺寸点阵LCD、中文菜单驱动软件, 信息丰富、直观、操作方便;
- 模块化设计, 自诊断功能, 维护简单;
- 报警输出(上、下限极值报警、温度报警、自检故障报警);
- 测量范围宽:
最小量程: 0~1%(O₂),
最大量程: 0~100%(O₂);
- 重要工作电源自检;
- 标准信号隔离输出(0/4~20mA)
- 两挡量程自动转换(量程转换1: 2);
- 仪器部件单元化, 维护、检修方便;
- 特殊量程由用户与生产厂家技术部门协商。

Features

- High explosion-proof class (d II CT6), suitable for Zone 1 and Zone 2 explosion hazard areas.
- Intelligent digital signal processing techniques, simplified and easy touch keys operations for calibrations of zero, span, and for parameter settings or changes.
- Fast response, excellent linearity, and high stability with unique sensor design and precise constant temperature control.
- Accurate measurement with microprocessor-based analog and digital signal conditioning.
- Large size LCD and Chinese menu-driven software for visual detailed information display and easy operations.
- Modular design with self-diagnostics for easy maintenance.
- Alarm outputs for high and/or low measurement, temperature, faulty by self-diagnostics.
- Wide measuring range:
Minimum range: 0~1%(O₂),
Maximum range: 0~100%(O₂)
- Important operating power self-check.
- Standard isolated output signal from 0/4mA to 20mA
- Auto-changed measuring range with ratio of 1:2;
- Parts unitization for convenient maintenance and overhauling.
- Special range available on consultation with the manufacturer.

气样条件 Sample conditions

序号 No.	影响量 Influence	额定工作范围 Ratings
1	气样温度 Temperature	5℃~40℃
2	气样压力 Pressure	2kPa~45kPa
3	气样流量 Flow	在12L/h内选择某一恒定值 A stable flow 12L/h
4	含水量 Moisture	进入仪器前经干燥处理 Dried before entering
5	含尘量 Dust	灰尘和机械杂质除净 Free of dust and other mechanical impurities

PA300-GTEx

智能隔爆氧分析仪器

PA300-GTEx Intelligent flameproof oxygen analyzer



概述

PA300-GTEx 智能隔爆氧分析仪器是采用电化学方法连续测量的工业用固定安装式仪器，是为了适应各种复杂的恶劣环境而开发的新一代隔爆型在线分析器，属于PA300Ex系列智能隔爆产品，仪器能连续自动测量、指示、记录流程气中氧的体积浓度。仪器采用微机技术，以菜单形式操作，实现多种自动功能。仪器用于有爆炸性危险的1区、2区环境的石油、化工、冶炼、建材、轻工及其它各种炉、窑或烟道等领域的氧气浓度分析。

General description

PA300-GTEx Intelligent flameproof oxygen analyzer, as an industrial field-fixed product using electrochemistry method for continuous and automatic oxygen volume concentration measurement in various process gases, is one of PA300Ex series new generation intelligent flame-proof instruments developed for harsh environment. This microprocessor-based analyzer features multiple automatic functions and menu-driven software operations. It is quite suitable for oxygen analysis in zone 1 and zone 2 explosion hazard areas of petroleum, chemical, metallurgy, cement, light industry, pharmaceutical and various furnaces, kilns or flues.

主要技术性能 Specifications

零点漂移 Zero-point drift	$\leq \pm 2\%FS/3d$
量程漂移 Span drift	$\leq \pm 2\%FS/3d$
线性误差 Linearity	$\leq \pm 1\%FS$
重复性误差 Repeatability	$Cv \leq 1\%$
响应时间 Response time	$\leq 10s$
预热时间 Preheating time	3h
输出信号 Output signals	0/4~20mA ($R_L \leq 600\Omega$)
防爆等级 Flameproof rank	d II CT6

仪器特点

- 防爆等级高, 适用于有爆炸性危险的1区、2区。
防爆等级: d II CT6
- 仪器信号及功能的智能化数字处理技术(零点、满度校准、线性校准、参数设置更改等), 感应键盘, 操作灵活方便;
- 传感器恒温控制(软件完成控制);
仪器稳定性好;
- 大尺寸点阵LCD、中文菜单驱动软件, 信息丰富、直观、操作方便;
- 模块化设计, 自诊断功能, 维护简单;
- 报警输出(上、下极限值报警、温度报警、自检故障报警);
- 测量范围宽
最小量程: 0~1%(O₂),
最大量程: 0~100%(O₂);
- 重要工作电源自检;
- 标准信号隔离输出(0/4~20mA)
- 两挡量程自动转换(量程转换1: 2);
- 仪器部件单元化, 维护、检修方便;
- 特殊量程由用户与生产厂家技术部门协商。

Features

- High explosion-proof class (d II CT6), suitable for Zone 1 and Zone 2 explosion hazard areas.
- Intelligent digital signal processing techniques, simplified and easy touch keys operations for calibrations of zero, span, and for parameter settings or changes.
- Precise sensor constant temperature control.
- High stability.
- Large size LCD and Chinese menu-driven software for visual detailed information display and easy operations.
- Modular design with self-diagnostics for easy maintenance.
- Alarm outputs for high and/or low measurement, temperature, faulty by self-diagnostics
- Wide measuring range:
Minimum range: 0~1%(O₂),
Maximum range: 0~100%(O₂)
- Important operating power self-check.
- Standard isolated output signal from 0/4mA to 20mA.
- Auto-changed measuring range with ratio of 1:2.
- Parts unitization for convenient maintenance and overhauling.
- Special range available on consultation with the manufacturer.

气样条件 Sample conditions

序号 No.	影响量 Influence	额定工作范围 Ratings
1	气样温度 Temperature	5°C ~ 40°C
2	气样压力 Pressure	0.03MPa~0.2MPa
3	气样流量 Flow	在12L/h内选择某一恒定值 A stable flow 12L/h
4	含水量 Moisture	进入仪器前经干燥处理 Dried before entering
5	含尘量 Dust	灰尘和机械杂质除净 Free of dust and other mechanical impurities

PA300-RQDEx

智能隔爆热导气体分析仪器

PA300-RQDEx Intelligent flameproof thermal conductivity gas analyzer



概述

PA300-RQDEx智能隔爆热导气体分析仪器是采用物理方法连续测量的工业用固定安装式仪器，是为了适应各种复杂的恶劣环境而开发的新一代隔爆型在线分析器，属于PA300Ex系列智能隔爆产品，仪器能连续自动测量、指示、记录流程气中H₂、Ar、CO₂等气体的体积浓度。仪器采用微机技术，以菜单形式操作，实现多种自动功能。仪器用于有爆炸性危险的1区、2区环境的石油、化工、冶炼、建材、轻工及其它各种炉、窑或烟道等领域的气体分析。

主要技术性能 Specifications

零点漂移 Zero-point drift	$\leq \pm 2\%FS/24h$
量程漂移 Span drift	$\leq \pm 2\%FS/24h$
线性误差 Linearity	$\leq \pm 2\%FS$
重复性误差 Repeatability	$Cv \leq 0.5\%$
响应时间 Response time	$\leq 40s$
预热时间 Preheating time	3h
输出信号 Output signals	0/4~20mA ($R_L \leq 600\Omega$)
测量组份 Measured Components	H ₂ , CH ₄ , Ar, etc.
防爆等级 Flameproof rankd	d II CT6

General description

PA300-RQDEx Intelligent flameproof thermal conductivity gas analyzer, as an industrial field-fixed product for continuous and automatic volume concentration measurement of various process gases, such as H₂, Ar, CO₂, etc. is one of PA300Ex series new generation intelligent flameproof instruments developed for harsh environment. This microprocessor-based analyzer features multiple automatic functions and menu-driven software operations. It is quite suitable for gas analysis in zone 1 and zone 2 explosion hazard areas of petroleum, chemical, metallurgy, cement, light industry, pharmaceutical and various furnaces, kilns or flues.

仪器特点

- 防爆等级高，适用于有爆炸性危险的1区、2区。
防爆等级：d II CT6
- 仪器信号及功能的智能化数字处理技术(零点、满度校准、线性校准、参数设置更改等)，感应键盘，操作灵活方便；
- 传感器恒温控制（软件完成控制）；
- 仪器稳定性好；
- 大尺寸点阵LCD、中文菜单驱动软件，信息丰富、直观、操作方便；
- 模块化设计，自诊断功能，维护简单；
- 报警输出(上、下极限值报警、温度报警、自检故障报警)；
- 测量范围宽
最小量程：0~1%(H₂)，0~15%(Ar、CO₂)，
最大量程：0~100%；
- 标准信号隔离输出(0/4~20mA)
- 两挡量程自动转换(量程转换1:2)；
- 仪器部件单元化，维护、检修方便；
- 特殊量程由用户与生产厂家技术部门协商。

Features

- High explosion-proof class (d II CT6), suitable for Zone 1 and Zone 2 Explosion hazard areas.
- Intelligent digital signal processing techniques, simplified and easy touch Keys operations for calibrations of zero, linearity, span, and for parameter Settings or changes.
- Precise sensor constant temperature control.
- High stability.
- Large size LCD and Chinese menu-driven software for visual detailed Information display and easy operations.
- Modular design with self-diagnostics for easy maintenance.
- Alarm outputs for high and/or low measurement, temperature, faulty by Self -diagnostics.
- Wide measuring range:
Minimum range: 0~1%(H₂), 0~15%(Ar、CO₂)
Maximum range: 0~100 %
- Standard isolated output signal from 0/4mA to 20mA.
- Auto-changed measuring range with ratio of 1:2.
- Parts unitization for convenient maintenance and overhauling.
- Special range available on consultation with the manufacturer.

气样条件 Sample conditions

序号 No.	影响量 Influence	额定工作范围 Ratings
1	气样温度 Temperature	5℃~40℃
2	气样压力 Pressure	0.6kPa~20kPa
3	气样流量 Flow	在12L/h内选择某一恒定值 A stable flow 12L/h
4	含水量 Moisture	进入仪器前经干燥处理 Dried before entering
5	含尘量 Dust	灰尘和机械杂质除净 Free of dust and other mechanical impurities

PA300Ex系列现场使用条件 PA300Ex Series influence operating conditions

条件 Conditions	序号 No.	影响量 Influence	额定工作范围 Ratings
气候条件 Ambient	1	环境温度 Temperature	5℃ ~ 40℃
	2	环境相对湿度 Relative humidity	≤85%
	3	大气压力 Atmospheric pressure	70kPa ~ 106kPa
	4	空气流速 Air-flow rate	≤0.5m/s
机械条件 Mechanica	1	工作位置 Operating position	仪器应水平放置 Placed horizontally
	2	机械振动和冲击 Vibration and shock	无强烈的振动和冲击 Without apparent mechanical vibration and shock
电源条件 Power supply	1	电源电压 Voltage	220V ± 22V
	2	电源频率 Frequency	50Hz ± 0.5Hz

PA300Ex系列外形尺寸(mm) PA300Ex Series outline dimension(mm)

注：部分机箱尺寸以说明书为准。

Note: The housing has two kind of types, please read the product operation and select the mounting dimension.

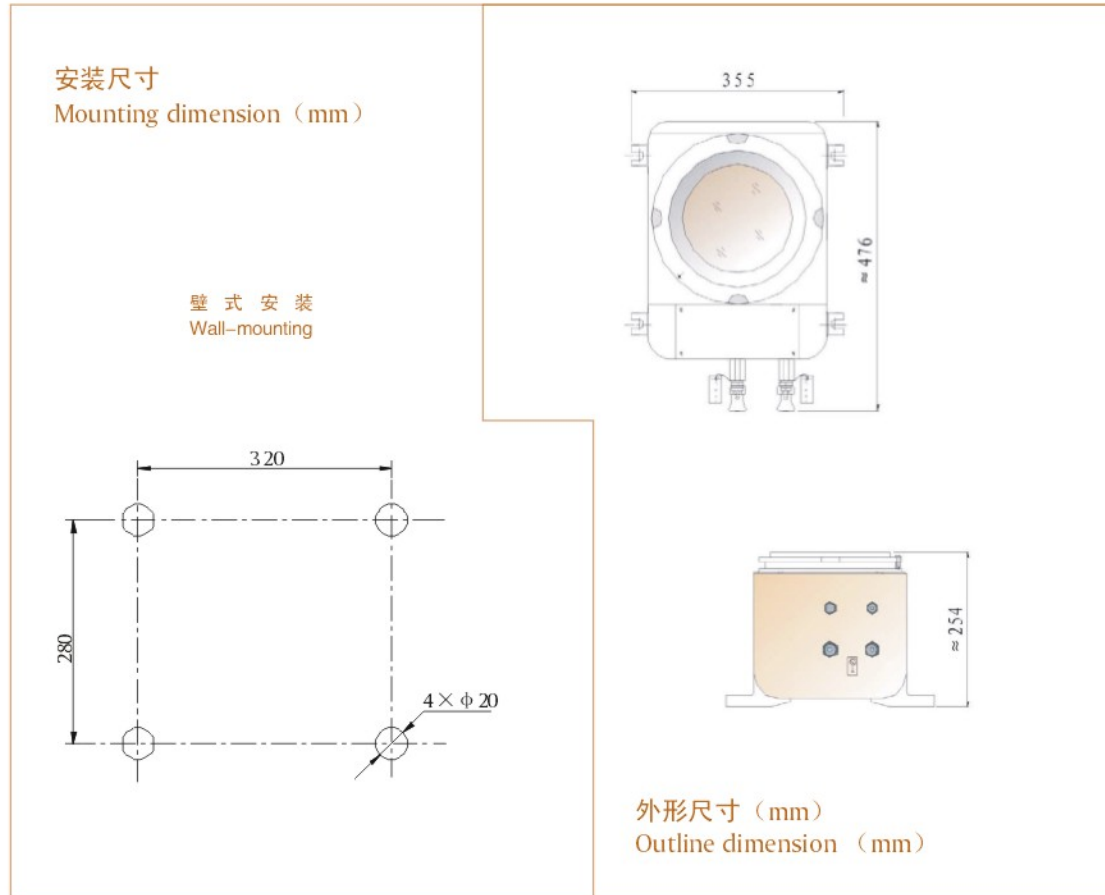

分析仪器应用条件 Analyzer application condition

仪器安装

仪器属固定安装式仪器，其安装形式有壁式安装和嵌入式安装二种（隔爆产品只有壁式安装）。由于安装形式的不同，仪器的气路接口和电缆接口有所不同。友情提示用户在签订合同时注明安装形式，以便仪器的气路接口和电接口适合用户要求，对合同上未注明安装形式的仪器均为嵌入式安装。

A. 壁式安装

将仪器的背面固定在垂直的安装面或框架上，并用仪器背面墙壁至少保持50mm的距离，以便于固定和仪器通风。壁式安装时电缆紧固螺丝应从仪器的右侧面装入，测量气体的出口和入口将从仪器的底面装入。要注意指示牌上标记符号与实际的气体出口和入口相一致。如果是隔爆产品，气路接口和电缆接口在仪器下方。

B. 嵌入式安装

嵌入式安装形式一般是将仪器安装在控制柜内时采用。控制柜安装仪器的这一面铁板厚度不得小于3mm。嵌入式安装时电缆紧固螺丝应从仪器的背面装入，测量气体的出口和入口也将从仪器的背面装入。要注意指示牌上标记符号与实际的气体出口和入口相一致。

气样处理

为了保证仪器的正常运行，在仪器投入运行之前必须配备一个适应于生产条件的取样和气样净化装置，使进入仪器的测量气体满足规定的要求。

通电前的检查

检查气路连接是否正确，检查电源和信号电缆的连接是否正确，仪器气密性是否达到要求。

维护注意事项

- A 在进行其它电缆连接前，先进行接地连接；
- B 确保仪器规定的工作电压与外接电源一致；
- C 打开箱盖前，必须首先切断仪器的总电源；
- D 必须带电维修时，应在安全环境中由一名专业人员进行，他应对可能产生的危险相当熟悉；
- E 仪器的电源切断后，仪器中的电容器还有可能有电；
- F 认为有可能发生危险时，应使仪器停止运转；
- G 按仪器的校对周期或用户实际情况每隔一定时间对仪器进行零点和终点的校对。

Installation

The instrument is a fixed product available for panel-mounting or wall-mounting. As the interfaces for gas and cables change with different mountings. To meet with your particular needs, a mounting type should be specified while ordering. The default is panel-mounting.

A. Wall-mounting

Fix the back of the instrument on a vertical plane or frame, keeping the back away from wall at least 50mm for easy installation and effective ventilation. The cable-fastening screws should be inserted from the right side of the instrument, the gas inlet and outlet from the bottom. Note that keeping actual gas direction accordance to those marks on the indication plate. For flameproof products, the interfaces for gas and cables are on the bottom.

B. Panel-mounting

Panel-mounting is generally used when the instrument will be installed in a control cabinet. The thickness of the mounting plane for the instrument should never less than 3mm. The cable-fastening screws should be inserted from the back of the instrument, the gas inlet and outlet also from the back. Note that keeping actual gas direction accordance to those marks on the indication plate. The interface between the tie-in and the machine box should be sealed and coated the sealant when all the interfaces are replaced.

Sample handling

To ensure normal operations, when necessary, a gas sampling and handling unit meeting with process conditions should be equipped to provide a sample specified by the instrument before it is put into use.

Checking before starting up

Check to ensure correct connections for gas, power supply, and signals.

Maintenance

- A Connect the grounding cable first before any other connections performed.
- B Ensure the external supply to meet with the instrument specification.
- C Turn off power supply before opening the cover of the instrument for maintaining, replacing any components or parts.
- D If necessary, maintenance with power on can and should be done in a safe area by a professional, who is quite familiar with any dangers that may occur.
- E Some capacitors in the instrument may still have electric charge for a time after power off.
- F Stop the instrument immediately when any risk may occur.
- G Performance regular zero and/or span calibrations upon specified schedules by the instrument or your particular needs.

选型指南 Selection guides

标准组态参数表 Standard parameter table

被测气体组分名称 Measured Components	化学分子式 Formula	背景气 Carrier gas	最小范围 Minimum range	最大范围 Maximum range
氧气(电化学、微量) Oxygen(Electro-chemistry and trace)	O ₂		0~10 ppm	0~200 ppm
氧气(电化学、常量) Oxygen(Electro-chemistry and macro)	O ₂		0~1%	0~100%
氧气(磁机械式) Oxygen (Magneto dynamic)	O ₂		0~1%	0~100%
氧气(磁压式) Oxygen(Magneto pneumatic)	O ₂		跨度(起点任意) Span=1%* ³	跨度(起点任意) Span=30%* ⁴
二氧化碳(非色散红外) Carbon dioxide(NDIR)* ¹	CO ₂		0~5 ppm	0~50%
一氧化碳(非色散红外) Carbon monoxide(NDIR)	CO		0~100 ppm	0~100%
甲烷(非色散红外) Methane(NDIR)	CH ₄		0~100 ppm	0~100%
二氧化硫(非色散红外) Sulfur dioxide (NDIR)	SO ₂		0~100 ppm	0~100%
一氧化氮(非色散红外) Nitric oxide(NDIR)	NO		0~300 ppm	0~100%
氨气(非色散红外) Ammonia(NDIR)	NH ₃		0~500 ppm	0~100%
氢气(热导) Hydrogen(TC) * ²	H ₂		0~5%	0~100%
氢气(热导) Hydrogen(TC)	H ₂	空气 Air	0~4%	80~100%
氢气(热导) Hydrogen(TC)	H ₂	Ar	0~3%	0~100%
氩气Argon(热导) Argon(TC)	Ar	N ₂	0~15%	0~100%
氩气(热导) Argon(TC)	Ar	O ₂	0~15%	0~100%
二氧化碳(热导) Carbon dioxide(TC)	CO ₂	空气 Air	0~20%	0~100%

*¹ NDIR = Non-dispersive infrared

*² TC = Thermal conductivity

*³ It means that any zero point can be set, but fullness subtracts the zero to be equal to 1%.

*⁴ It means that any zero point can be set, but fullness subtracts the zero to be equal to 30%.

According to the user's request, we can design instrument with special measured component, the special measuring range or the measuring range beginning is not the zero, then the instrument technical parameters may redefine.

测量选型指南 Measure selection guides

测量/应用 Application	检测技术 Measurement technique	仪器型号 Instrument model list
二氧化碳 Carbon dioxide (CO ₂)	非色散红外 NDIR ^{*1}	PA100-GXH、PA200-GXH、PA300-GXHEx ^{*2}
一氧化碳 Carbon monoxide (CO)	非色散红外 NDIR	PA100-GXH、PA200-GXH、PA300-GXHEx
甲烷 Methane (CH ₄)	非色散红外 NDIR	PA100-GXH、PA200-GXH、PA300-GXHEx
二氧化硫 Sulfur dioxide(SO ₂)	非色散红外 NDIR	PA200-GXH
氨气 Ammonia (NH ₃)	非色散红外 NDIR	PA100-GXH、PA200-GXH、PA300-GXHEx
一氧化氮 Nitric oxide (NO)	非色散红外 NDIR	PA200-GXH
氧气 Oxygen(O ₂) 【微量Trace】	电化学 Electro-chemistry	PA200-DH
氧气 Oxygen(O ₂) 【百分比percent】	电化学 Electro-chemistry	PA200-GT、PA300-GTEx
氧气 Oxygen(O ₂) 【百分比percent】	磁机械式 Magneto dynamic	PA100-CJ、PA200-CJ、PA300-CJEx
氧气 Oxygen(O ₂) 【百分比percent】	磁压力式 Magneto pneumatic	PA200-CY
氢气 Hydrogen(H ₂)	热导 Thermal conductivity(TC)	PA100-RQD、PA200-RQD、PA300-RQDEx
氩气 Argon(Ar)	热导 Thermal conductivity(TC)	PA100-RQD、PA200-RQD、PA300-RQDEx
空分 Air-separation (CO ₂ ,O ₂ ,H ₂ ,Ar)	非色散红外 NDIR、热导 TC	PA100-GXH、PA200-GXH、PA300-GXHEx
	电化学 Electro-chemistry	PA100-RQD、PA200-RQD、PA300-RQDEx
	磁机械式 Magneto dynamic	PA200-DH、PA200-GT、PA300-GTEx
	磁压力式 Magneto pneumatic	PA200-CY、PA100-CJ、PA200-CJ、PA300-CJEx
空分 Air-separation (高端 High O ₂)	磁压力式 Magneto pneumatic	PA200-CY
烟气排放监测系统 CEMS ^{*3} (SO ₂ , NO, CO ₂ , O ₂)	非色散红外 NDIR、热导 TC	PA100-GXH、PA200-GXH、PA300-GXHEx
	电化学 Electro-chemistry	PA200-GT、PA300-GTEx、PA200-CY
	磁机械式 Magneto dynamic	PA100-CJ、PA200-CJ、PA300-CJEx
	磁压力式 Magneto pneumatic	
烟气排放监测系统(红外组份+O ₂) CEMS (Infrared component + O ₂)	非色散红外 NDIR	PA200-GXH+O ₂
	电化学 Electro-chemistry	
化工 Chemical industry (CH ₄ , CO ₂ , CO, NO, H ₂ , O ₂)	非色散红外 NDIR、热导 TC	PA100-GXH、PA200-GXH、PA300-GXHEx
	电化学 Electro-chemistry	PA100-RQD、PA200-RQD、PA300-RQDEx
	磁机械式 Magneto dynamic	PA200-DH、PA200-GT、PA300-GTEx
	磁压力式 Magneto pneumatic	PA200-CY、PA100-CJ、PA200-CJ、PA300-CJEx
冶金 Metallurgy industry (CO ₂ , CO, H ₂ , O ₂)	非色散红外 NDIR、热导 TC	PA100-GXH、PA200-GXH、PA300-GXHEx
	电化学 Electro-chemistry	PA100-RQD、PA200-RQD、PA300-RQDEx
	磁机械式 Magneto dynamic	PA200-GT、PA300-GTEx、PA200-CY
	磁压力式 Magneto pneumatic	PA100-CJ、PA200-CJ、PA300-CJEx
建材 Building material (CO ₂ , CO, H ₂ , O ₂)	非色散红外 NDIR、热导 TC	PA100-GXH、PA200-GXH、PA300-GXHEx
	电化学 Electro-chemistry	PA100-RQD、PA200-RQD、PA300-RQDEx
	磁机械式 Magneto dynamic	PA200-GT、PA300-GTEx、PA200-CY
	磁压力式 Magneto pneumatic	PA100-CJ、PA200-CJ、PA300-CJEx
建材 Building material (Infrared component + O ₂)	非色散红外 NDIR	PA200-GXH+O ₂
	电化学 Electro-chemistry	

*1 NDIR = non-dispersive infrared

*2 Flameproof type

*3 CEMS = Continuous emission monitoring system

典型业绩 Typical achievements

建材水泥行业

Timbering cement industry

巴基斯坦AWT NCP水泥厂 (1-2号窑)
Pakistan AWT NCP Cement Factory (1st-2nd stove)
巴基斯坦LUCKY水泥厂 (1-2号窑)
Pakistan LUCKY Cement Factory (1st-2nd stove)
中材建设有限公司 (出口阿尔巴尼亚)
CBMI Construction Co., Ltd.(export Albania)
阿曼RAYSUT水泥公司
Oman RAYSUT Cement Company
西仪进出口公司 (出口伊朗)
West Meter Import-export Company (export Ifran)
苏州中材建设有限公司 (出口越南福山水泥有限公司)
Sinoma(Suzhou) Construction Co.,Ltd.
(export Vietnamese Fushan Cement Co.,Ltd)
陕西秦岭水泥股份有限公司 (1-6号窑)
Shanxi Qinling Cement Joint-stock Co.,Ltd.(1st-6th stove)
湖北葛洲坝水泥厂 (3-5号窑)
Hubei Gezhouba Cement Factory(3rd-5th stove)
云南红塔集团滇西水泥厂 (1-3号窑)
Yunnan Hongta Cooperation Dianxi Cement (1st-3rd stove)
重庆拉发基水泥厂
Chongqing Lafarge Cement Factory
亚泰集团双阳水泥厂 (1-2号窑)
Jilin Yatai (Group) Shuangyang Cement (1st-2nd stove)
广东广信青州水泥厂
Guangdong Guangxin Qingzhou Cement Factory
浙江三狮集团长兴水泥厂
Zhejiang Leomax Group Changxin Cement Factory
安徽海螺水泥集团 (10000T/d)
Anhui Conch Cement Group(10000T/d)
拉法基北京兴发水泥厂 (1-2分号窑)
Lafarge Beijing Xinfu Cement (1st-2nd stove)
福建水泥股份有限公司
Fujian Cement Stock Co.,Ltd.
陕西汉江建材股份有限公司
Shanxi Hanjiang Timbering Co.,Ltd.
云南通海秀山水泥有限责任公司
Yunnan Tonghai XiuShan Cement Co.,Ltd.
祁连山水泥股份有限公司
Qilianshan Cement Co.,Ltd.
沙特RDCC、SPCC公司
Saudi Arabia RDCC,SPCC Company

冶金钢铁行业

Metallurgy&Steel industry

武汉钢铁公司 (转炉煤气、焦炉煤气、高炉、石灰窑等)
Wuhan Steel Co.(converter coal gas, cokery Coal gas,blast fumace,limekiln...)
出口印度 (高炉喷煤)
Export India (blast fumace spout coal)
山西海鑫国际钢铁有限公司
Shanxi Haixin International Steel Co.,Ltd.
涟源钢铁公司 (高炉喷煤、转炉煤气)
Lianyuan Steel Co.(blast furnace spout coal, converter coal gas)
重庆钢铁公司 (高炉喷煤、转炉煤气)
Chongqing Steel Co.(blast furnace spout coal, converter coal gas)
济南钢铁公司 (焦炉煤气、防爆分析小屋)
Ji'nan Steel Co.(cokery Coal gas, Explosion Protection analytical house)
大冶特殊钢股份有限公司 (高炉)
Daye Steel Co.,Ltd.(blast furnace)
马鞍山钢铁公司 (转炉煤气、冷轧)
Maanshan Steel Co.(converter coal gas, cold rolling)
唐山钢铁公司 (高炉喷煤)
Tangshan Steel Co.(blast furnace spout coal)
韶铁松山股份有限公司 (高炉喷煤)
Shaotie Songshan Co.,Ltd.(blast furnace spout coal)
本溪钢铁公司 (转炉煤气)
Benxi Steel Co.(converter coal gas)
酒泉钢铁公司 (焦炉喷煤、高炉喷煤)
Jiuquan Steel Co.(cokery spout coal, blast furnace spout coal)
湖北鄂州钢铁公司 (高炉喷煤、转炉煤气)
Hubei Ezhou Steel Co.(blast furnace spout coal, converter coal gas)
通化钢铁公司 (高炉喷煤)
Tonghua Steel Co.(blast furnace spout coal)
首都钢铁公司 (高炉、转炉煤气)
ShouGang Co.(blast furnace, converter coal gas)
攀枝花钢铁公司 (焦炉煤气、冷轧)
Panzhuhua Steel Co.(cokery coal gas, cold rolling)
石家庄钢铁公司 (转炉煤气)
Shijiazhuang Steel Co.(converter coal gas)
福建三明钢铁有限公司 (高炉喷煤)
Fujian Sanming Steel Co.,Ltd. (blast furnace spout coal)
天津铁厂 (高炉)
Tianjin Steel Factory (blast furnace)
北台钢铁 (集团) 有限责任公司 (高炉喷煤)
Beitai Steel (Group) Co.,Ltd.(blast furnace spout coal)

化工、化肥、石化行业

Chemical, Fertilizer, Petrification industry

巴陵石油化工有限公司 (钠酰胺工程)
Baling Petrochemical Co.,Ltd (natrium-maleimide project)
西仪横河公司 (出口印尼碱厂碳酸项目)
Yokogawa(Xi'an) Instrumentation Co.,Ltd.
(Export Indonesia alkali Factory for Creosote project)
太原化学工业公司 (光气合成分析系统)
Taiyuan Chemical Industry Co.
(Phosgene compose analytical system)
青岛石油化工厂 (催化裂化烟气)
Qingdao Petroleum Laboratory (catalyse cracking smoke)
兰化公司化肥厂 (重油原料制取水/半水煤气)
Lanhua Company Fertilizer Factory
(heavy oil material making water/half-water gas)
四川维尼纶厂 (天然气制乙炔、甲烷)
Sichuan Ninon Factory (natural gas making ethine ,methane)
大连西太平洋石油化工有限公司 (催化裂化)
West Paific Petrochemical Co.,Ltd. Dalian (catalyse cracking)
天津化工厂 (树脂工艺氯乙烯)
Tianjin Laboratory (colophony technics chloroethylene)
大庆石化总厂 (醋酸)
Daqing Petrification Chief Factory (vinegar)
云南天然气化工厂 (天然气分析)
Yunnan Natural Gas Laboratory (natural gas analyer)
上海石化股份有限公司 (CO₂分析)
Shanghai Petrification Co.,Ltd. (CO₂analyer)
广西河池化肥厂 (半水煤气)
Guangxi Hechi Fertilizer Factory (half-water gas)
黑龙江浩良河化肥厂 (油改煤工程)
Heilong River Lianghe Fertilizer Factory (Oil changing to coal project)
中石化南京化工厂 (H₂气体分析系统)
Sinopec Nanjing Laboratory (H₂ Gas analytical system)
河南骏马化工股份有限公司 (合成氨)
He'nan Courser Chemical Co.,Ltd. (synthetic ammonia)
巨化集团公司合成氨厂 (合成氨)
Juhua Group Co. Synthetic Ammonia Factory (synthetic ammonia)
中石化扬子石化公司 (65万吨乙烯)
Sinopec Yangzi Petrification Co.(650 thousand tons ethne)
中州铝厂新乡化工厂 (联碱项目)
Zhongzhou Aluminium Factory Xinxiang Laboratory (Join-alkali project)
安徽淮化集团有限公司 (尿素、合成氨)
Anhui Huaihua Group Co.,Ltd. (carbamide ,synthetic ammonia)
河南蓝天集团有限公司 (甲醇)
He'nan Lantian Group Co.,Ltd. (Methanol)

电力行业

Electric power industry

重庆华能珞璜电厂 (脱硫SO₂分析)
Chongqing Huaneng Luohuang Power Station (desulfurize SO₂ analysis)
巴基斯坦拉克拉电厂
Pakistan lakela Power Station
宜宾豆坝电厂 (脱硫SO₂分析)
Yibing Douba Power Station (desulfurize SO₂ analysis)
清华同方能源工程部 (烟气O₂、SO₂、H₂S分析)
Tsinghua Tongfang Energy Project Dept. (smoke O₂、SO₂、H₂S analysis)
陕西蒲城电厂 (脱硫SO₂分析)
Shanxi Pucheng Power Station (desulfurize SO₂ analysis)
江西贵溪电厂 (烟气脱硫)
Jiangxi Guixi Power Station (smoke desulfurize)
呼和浩特发电厂 (烟气排放)
Huhehaote Power Station (smoke let)
盘锦辽河常腾热电厂 (烟气排放)
Panjing Liaohe Changteng Thermoelectricity Factory (smoke let)
杭州热电厂 (烟气排放)
Hnagzhou Thermoelectricity Factory (smoke let)
山东宁阳热电厂 (烟气脱硫)
Shandong Lingyang Thermoelectricity Factory (smoke let)
贵州野马寨电厂 (4*60万)
Guizhou Bronco Stockaded Village Power Station (4*600 thousand)
四川白马电厂 (30万)
Sichuan White-Horse Power Station (300 thousand)
贵州黔西电厂 (4*30万)
Guizhou Qianxi Power Station (4*300 thousand)
贵州大龙电厂 (4*30万)
Guizhou Big-Dragon Power Station (4*300 thousand)
四川江油电厂 (2*30万)
Sichuan Jiangyou Power Station (2*300 thousand)
岷江电厂 (4*30万)
Mingjiang Power Station (4*300 thousand)
山东兖矿电厂 (2*13.5万)
Shandong Yankuang Power Station (2*135 thousand)
辽宁东方发电有限公司 (2*35万)
Liaoning Eastern Generate Electricity Co.,Ltd. (2*350 thousand)
四川攀枝花三维发电厂 (2*3.5万)
Sichuan Pazihua Sanwei Power Station (2*35 thousand)
兰州酒钢自备电厂 (2*13.5万)
Lanzhou Jiugang Zibei Power Station (2*135 thousand)

空分行业

Air separation analysis industry

杭州制氧机厂（出口朝鲜、沙特）
Hangzhou Making-Oxygen Instrument Factory
(export Korea, Saudi Arabia)
四川空分设备有限公司
(出口叙利亚、土耳其、朝鲜)
Sichuan Atmosphere Analysis Instrument Co.,Ltd.
(export Syria, turkey, Korea)
开封空分集团公司（出口越南、阿曼）
Kaifeng Atmosphere Analysis Group Co.
(export Vietnam, Oman)
黑龙江化工总厂（空分成套系统）
Heilongjiang Laboratory
(atmosphere analysis system)
锦西炼油化工厂（氢纯度分析）
Jingxi Oil Refining Laboratory
(Hydrogen hallmark)
武汉钢铁公司氧气厂（6000空分）
Wuhan Steel Co. Oxygen Factory
(6000 atmosphere analysis system)
邯郸钢铁公司氧气厂（10000空分）
Handan Steel Co. Oxygen Factory
(10000 atmosphere analysis system)
哈尔滨制氧机厂
Haerbin Making-Oxygen Instrument Factory
天津铁厂氧气分厂
Tianjin Ironworks Making-Oxygen Instrument Factory
河南安阳钢铁公司氧气厂（6000空分）
He'nan Anyang Steel Co. Oxygen Factory
(6000 atmosphere analysis system)

生物制药 轻工行业

Biology pharmacy, Light industry

上海宝兴生物工程有限公司（生物尾气）
Shanghai Boxin Bioengineering Co.,Ltd. (Biology trail gas)
深圳云峰（生物尾气）
Shengzheng Yunfeng (Biology trail gas)
内蒙金河工程生物技术有限公司（尾气发酵）
Neimeng Goden-River Bioengineering Techology Co.,Ltd. (Trail gas ferment)
上海国强生化公司（生物尾气）
Shanghai Guoqiang Bioengineering Co. (Biology trail gas)
华北制药股份有限公司（生物尾气发酵）
Huabei Pharmacy Co.,Ltd. (Biology trail gas ferment)
西安制药有限公司（尾气发酵）
Xi'an Pharmacy Co.,Ltd. (Biology trail gas ferment)
江西东风制药有限公司（尾气发酵）
Jiangxi Dongfeng Pharmacy Co.,Ltd. (Biology trail gas ferment)
浙江振远制药有限公司（尾气发酵）
Zhejiang Zhenyuan Pharmacy Co.,Ltd. (Biology trail gas ferment)
印度尼西亚永吉纸业公司（空气分离）
Indonesia Yongji Bumf Co. (atmosphere separate)
明达玻璃（厦门）有限公司（浮法玻璃）
Mingda Glass (Ximen) Co.,Ltd. (Flaat Glass)
北京大学
Peking University
武汉大学
Wuhan University
重庆大学
Chongqing University
四川大学
Sichuan University
解放军第三军医大学
Network Center of Third Military Medical University
中国科学院成都有机化学研究所
Chengdu Organic Chemistry Co.,Lid Chinese Academy of Sciences
中石油川西北天然气科学研究所
CNPC Chuanxibei Natural Gas Academy of Sciences
四川省精细化工研究院
Sichuan Chemical Academy of Natural Gas
中昊晨光化工研究院
Zhonghao Chenguang Research Institute of Chemical Industry
重庆市疾病预防控制中心
Chongqing Municipal Center for Disease Control & Prevention

工业在线分析仪器

Industrial on-line analyzer



重庆川仪分析仪器有限公司

Chongqing Sichuan Instrument Analyzer Co., Ltd.

地址：中国重庆经济技术开发区南坪金山支路6号 400060

Address : No.6 jinshan lane, Nanping, Economic & Technological

Development Zone , Chongqing, P.R China 400060

电话/TEL: +86 (0) 23 62825599 (总机)

+86 (0) 23 62827694 (分析仪器部 Analyzer Dept.)

62836914 (系统成套/ 环保部 Integrated system Dept.)

62803141 (水质仪器部 Liquid Dept.)

传真/FAX: +86 (0) 23 62803142

服务热线/Service Line: +86 (0) 23 62817540

Http: // www.cqcf.com