



百特粒度仪 **国产好仪器**

BT-Online1A

干法在线激光粒度监测与控制系统



安装在生产现场

自动取样

自动测试

自动控制 (选配)

丹东百特仪器有限公司



走进百特

丹东百特仪器有限公司成立于 1995 年，经过持续创新和诚信经营，百特已经发展成为业界领先的粒度粒形仪器和技术提供商，百特仪器和技术正在成为国内外材料学专家、应用工程师和广大科研工作者进行粒度粒形分析的新选择。

百特仪器和技术对纳米、微米和毫米级材料，都能得到真实准确的粒度粒形和物理特性分析结果。支撑这些分析的仪器包括百特激光粒度仪、图像粒度粒形分析仪、纳米粒度及 Zeta 电位分析仪、沉降粒度仪、粉体综合特性测试仪等；支撑这些分析的技术包括 100 多项专利（其中发明专利 23 项），28 项软件著作权，140 多项仪器制造专有技术和 300 多项质量工作规范等。此外，百特顶级应用专家和几十位服务工程师提供专业、周到的服务支持，使百特仪器具有业界领先的技术内涵。不仅如此，百特仪器受到用户的青睐，还在于它的坚固耐用、低故障率和一键式操作等高品质特质，每一台仪器都是百特人经过几十道工序精心打造而来，包含着百特人的梦想、智慧和精益求精的工匠精神。

简而言之，百特是一家“诚实守信 + 创新驱动 + 工匠精神 + 服务用户”的公司。百特仪器不仅销售到全国 34 个省市区，还出口到德国、美国、韩国、印度、越南、巴西、俄罗斯等 90 多个国家和地区；截止 2023 年，百特仪器的国内外市场保有量超过 23000 台，是世界粒度粒形仪器市场保有量最多的品牌之一。





业界楷模

百特公司通过 ISO9001 质量体系认证，产品通过欧洲 CE 认证。符合 21 CFR Chapter I Subchapter J, Part 1040.10 and 1040.11 规范和 FDA 21 CFR Part 11 规范，保证了结果的有效性和可靠性，同时符合相关法规要求。



SWISS APPROVAL Objectivity Trust	CERTIFICATE of Compliance	Cert No: 086-03-026-0083 Date of Issue: 18/06/2022
Holder	Dandong Betterize Instruments Ltd. No.9 Gangqun Road, Jinqun Industrial Park, Dandong City, Liaoning Province, P. R. China	
Manufacturer	Dandong Betterize Instruments Ltd. No.9 Gangqun Road, Jinqun Industrial Park, Dandong City, Liaoning Province, P. R. China	
Product Description	Laser Particle Size Analyzer	
Model(s)	BT-9300SE, BT-9300S, BT-9300ST, Betterize2600CE, Betterize2600, Betterize2000, Betterize2000E, Betterize2000S, Betterize2000, Betterize2000Plus, Betterizer SE, Betterizer S, Betterizer ST, Betterizer SD, Betterizer 2600E, Betterizer 2600, Betterizer S3, Betterizer S3 Plus, Betterizer S2, Betterizer S2-E	
Requirements and Standard(s)	Low Voltage Directive 2014/35/EU Electromagnetic Compatibility 2014/30/EU EN 61010-1:2016+A1:2019+AC:2019-04, EN 61326-1:2013	
Report No.	086-03-011-06287	
Date of Expiry	18/06/2027	
<p>SWISS APPROVAL TECHNISCHE BEWERTUNG S.A. as a Third Party Certification Body, hereby certifies that the above mentioned products were witnessed by us during testing when applicable, and also the Technical File, has been received, archived and proceed to the fullness examination by us and we confirm that the Technical File is adequate in respect with the basic health and safety pre-requisites of above mentioned requirements and standard(s).</p> <ul style="list-style-type: none"> This Certificate is issued in conjunction with the above mentioned Report and reflects findings during inspection in time and place only for the product and configuration described hereby and does not release buyer and/or seller from their contractual responsibilities. All modifications to the Technical File should be first submitted to our Company to ensure further validity of this attestation. The CE marking can be used, under the responsibility of the manufacturer, after completion of an EC Declaration of Conformity and compliance with relevant EU standards and regulations. The certificate of compliance refers only to the requirements of the above mentioned standards and does not indicate a Notified Body certification under EU directive but only a voluntary control at the request of the manufacturer according to a scope chosen by the manufacturer. 		
 Inspector Henry Cai		 In behalf of Company Tzafaris Mektos
<small> #F02_HenryCai SWISS APPROVAL TECHNISCHE BEWERTUNG S.A. Technischer und Organisatorischer Leiter www.swissapproval.ch www.tzafaris.com www.betterize.com info@swissapproval.ch </small>		





基本性能指标

- 测试范围：0.1-2000 μm
- 重复性误差： $\leq 1\%$ （标样 D50 偏差）
- 准确性误差： $\leq 1\%$ （标样 D50 偏差）
- 测量原理：Mie、Fraunhofer
- 取样方式：具有防堵设计的文丘里负压取样
- 镜头防护：双层气幕防护
- 维护周期： ≥ 180 天
- 激光光源：进口光纤激光器
- 操作系统：Windows
- 控制方式：Modbus - RTU 协议、TCP 协议、4 - 20 mA
- 光电探测器：92 个
- 分散介质：压缩空气或氮气等惰性气体
- 气源：0.4-0.8 MPa
- 防护等级：IP65
- 样品量：1-10 克 / 次
- 电源：AC220 V、50/60 Hz、200 W
- 体积：782×530×1592 mm（主机）
- 重量：85 kg

监测项目

- 粒度分布
- D10、D50、D90、D97、D98 等
- 典型区间含量：如 $< 3 \mu\text{m}$ 、3-32 μm 、32-65 μm 、 $> 45 \mu\text{m}$ 、 $> 80 \mu\text{m}$ 等
- 体积平均径 D[4,3]
- 面积平均径 D[3,2]
- 比表面积

应用领域

- 水泥、炭素、石墨等大规模产线及新能源、制药等精细化产线，可与多种生产干粉磨机配套。



简要说明

- BT-Online1A 是一种应用于精细化粉体生产线上实时进行粒度监测与控制的在线粒度监测控制系统。它安装在气流磨、立磨等干法磨旁边，实现自动取样，自动测量和自动控制。

系统应用示意图

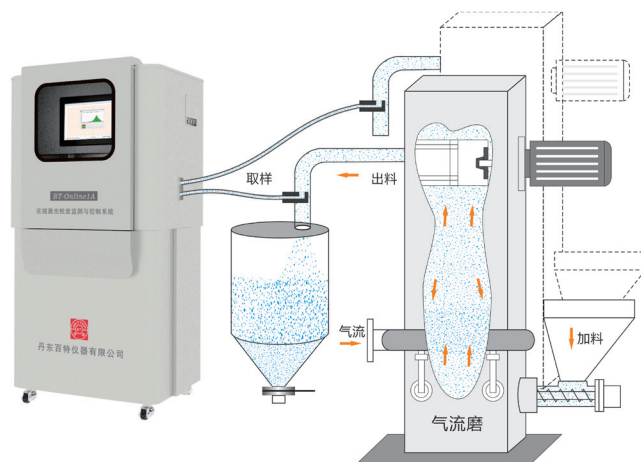

控制系统 BT-Online1A (适用于精细化制粉车间)

独特技术 (之一)

- 激光衍射技术: 在正反傅里叶光路系统中安装了大口径傅氏透镜和大尺寸的光电探测器阵列, 探测器数量达 92 个, 实现了对散射信号的精准探测, 提升了测量范围, 提升了细颗粒端的测量精度, 提升了分辨率。

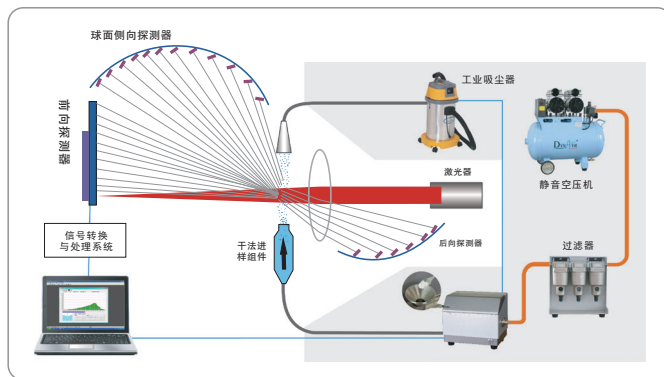

- 自动对中技术: 由精密执行单元和控制单元组成的自动对中系统, 即使因环境振动等因素导致光路发生偏移, 系统将自动校正, 保证光路系统始终处于最佳状态。

- 干法分散技术: 配有干法分散器 (选配), 对团聚特性强的产品也能得到准确粒度结果。

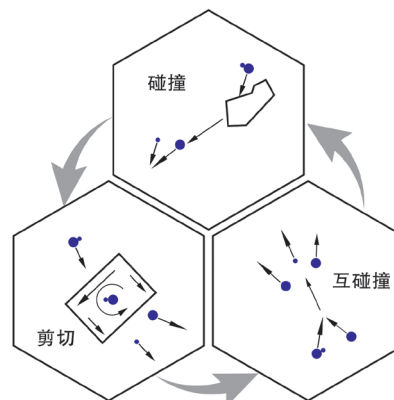
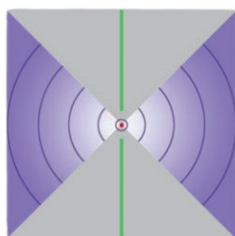
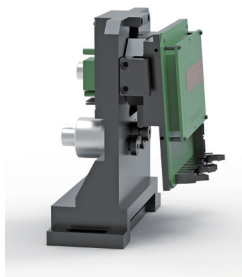

- 一键操作: 启动设备后, 软件点击“启动”按钮, 仪器自动执行在线取样、分散、测试、回收等测试流程, 实现粉体生产粒度在线监控自动化。

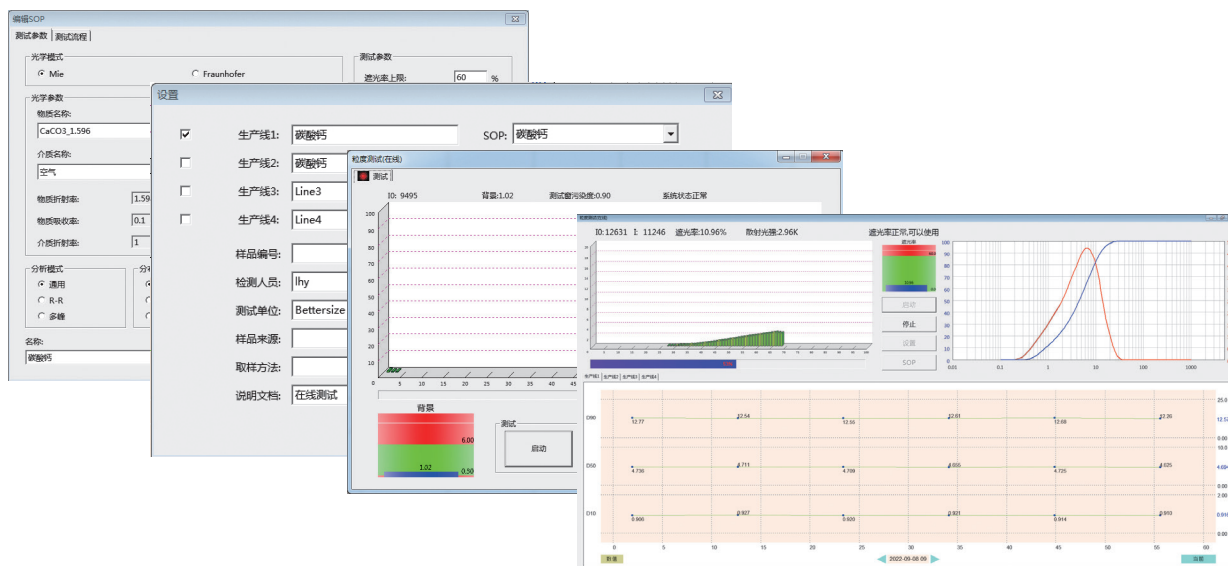



独特技术（之二）

- 多种取样技术: 文丘里负压取样, 可通过笛型取样管直接从管道里取样, 也可通过铰刀取样器取样, 取样系统具有分散、防堵、反吹、防静电和多点取样设计, 代表性好。

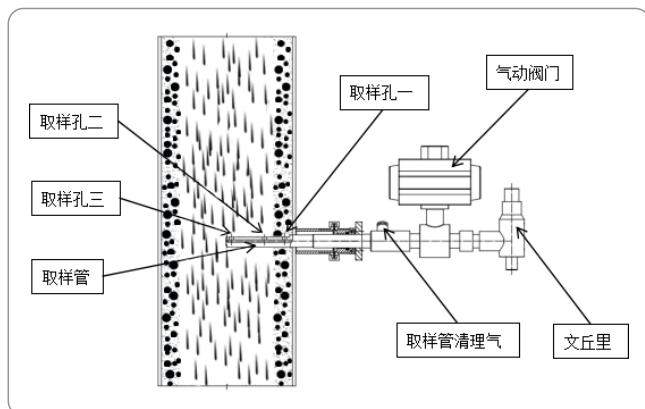

风送取样

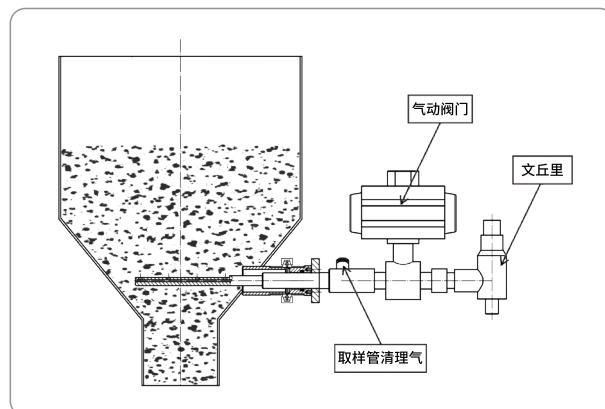

料仓取样

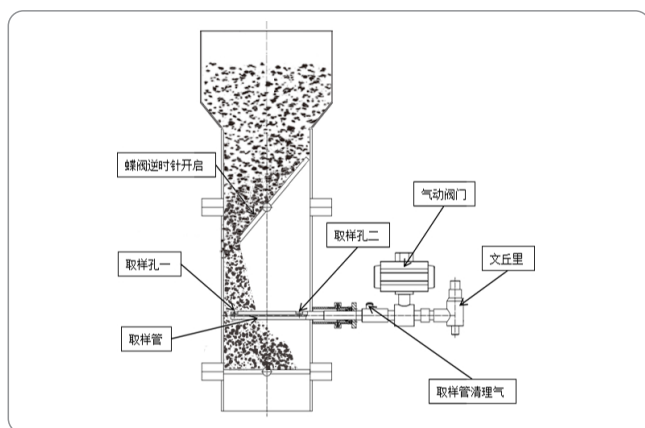

下落取样

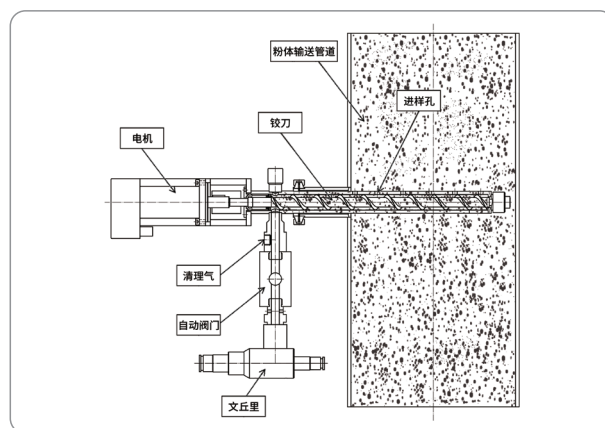

铰刀取样

- 镜头防护技术: 根据空气动力学原理, 在镜头和测试区之间采用双气幕防护, 使镜头免受样品污染, 维护周期 ≥ 180 天。

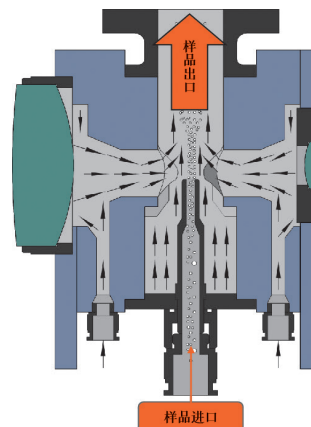

控制系统 BT-Online1A (适用于精细化制粉车间)

- 准确性、重复性、分辨力：结果堪与实验室仪器结果相媲美。

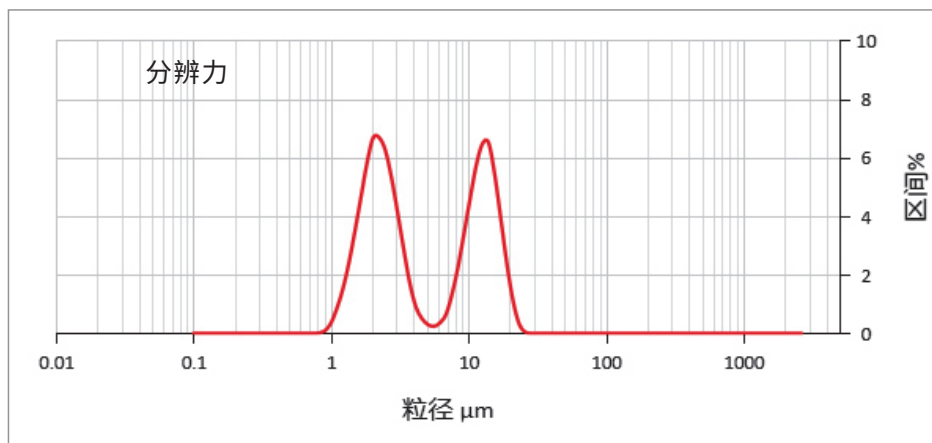
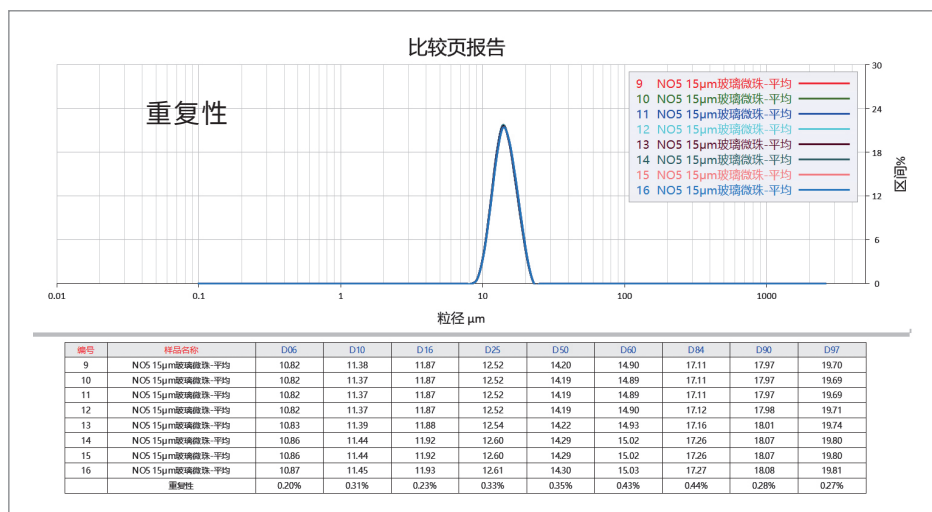
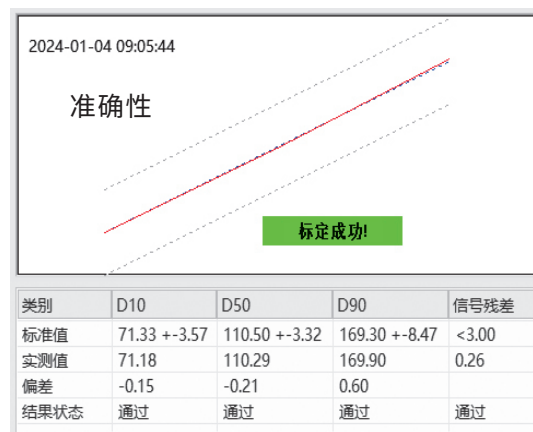
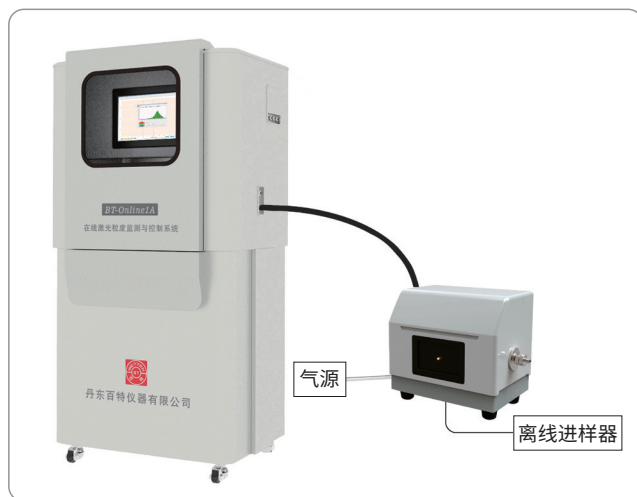



关于在线激光粒度监测与控制系统

生产流程

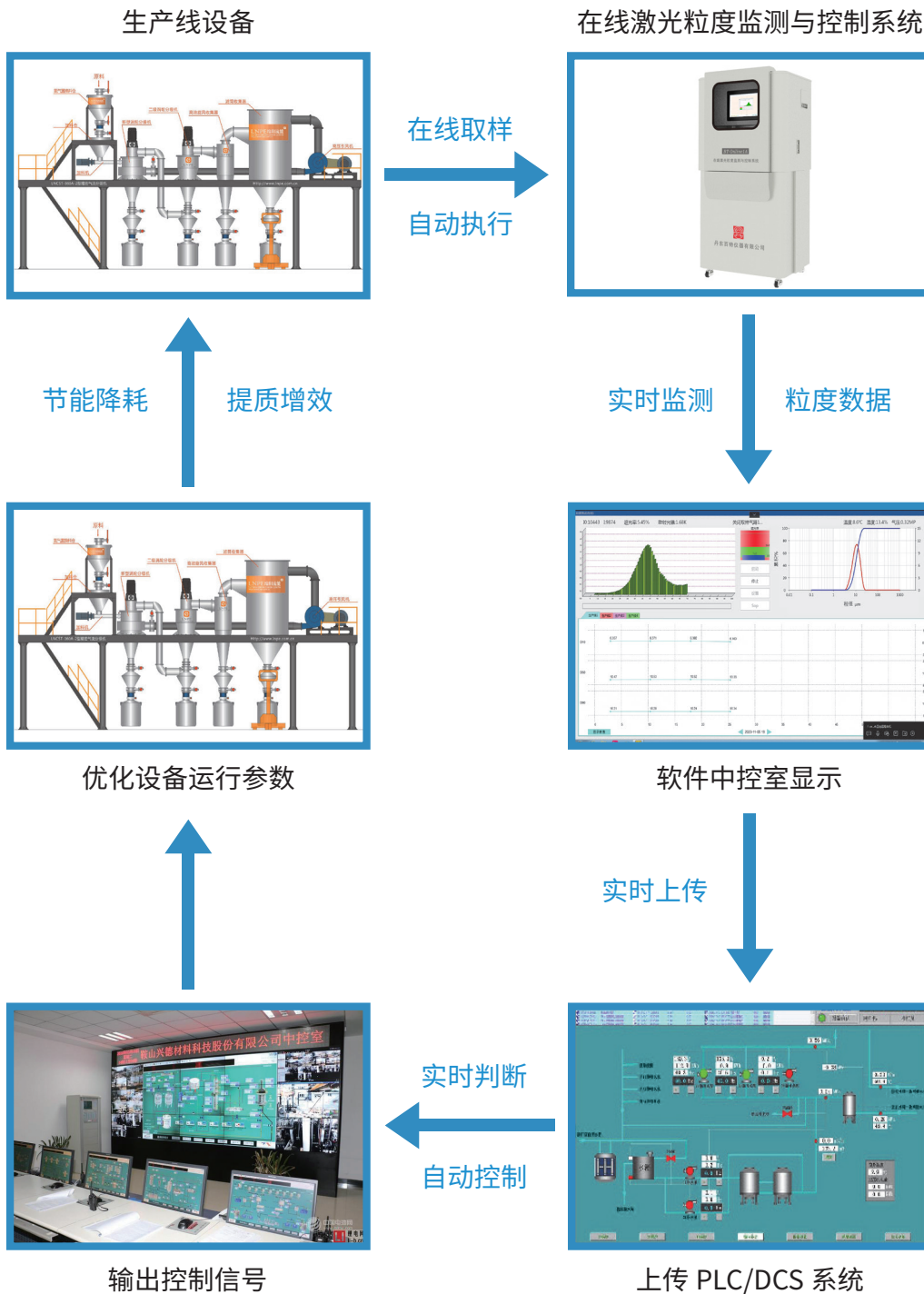



报告单样式



BT-Online1 在线激光粒度分析仪 粒度分析报告

测试范围: 0.10μm - 1000μm

样品名称: NO2 炭素-平均	样品编号:	样品来源: Bettersize
测试人员:	测试时间: 2023-02-218:08:29	测试单位: Bettersize
物质折射率: 2.42	物质吸收率: 1	介质折射率: 1
光学模式: Mie	分析模式: 通用	分布类型: 体积分布
介质名称: 空气	分散剂:	备注: 在线测试

原始信息区

体积平均径D[4,3] 49.68 μm	面积平均径D[3,2] 18.77 μm	数量平均径D[1,0] 3.130 μm	峰值粒径: 66.98 μm
跨度: 2.541	比表面积: 118.3m ² /kg	拟合残差: 5.492 %	遮光率: 0.38 %
D03 = 3.857 μm	D06 = 5.784 μm	D10 = 8.141 μm	D16 = 11.55 μm
D25 = 17.04 μm	D50 = 39.29 μm	D84 = 91.02 μm	D90 = 108.0 μm
D75 = 73.06 μm	D90 = 108.0 μm	D97 = 143.1 μm	

典型数值区

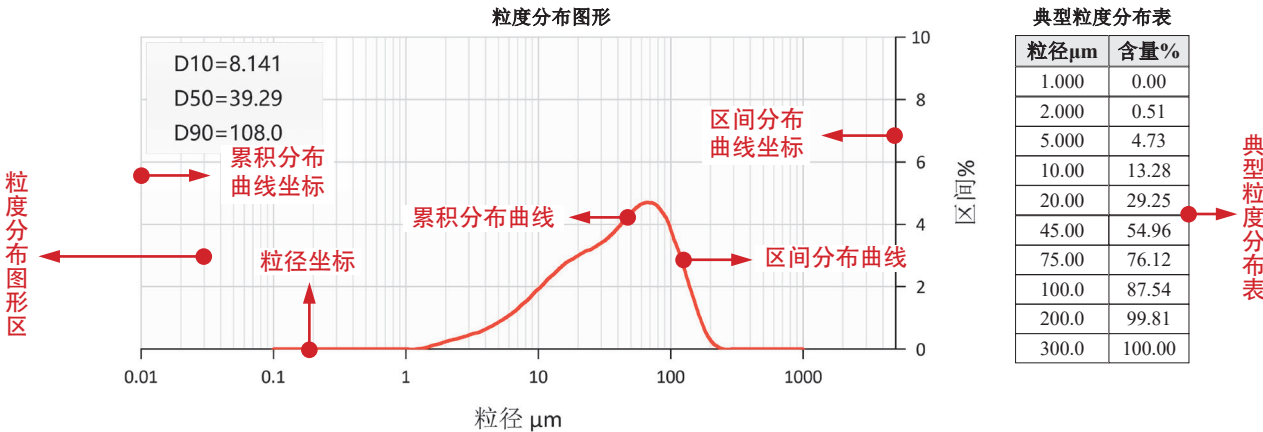

典型粒度分布表

粒度分布详细表

粒径μm	区间%	累积%	粒径μm	区间%	累积%	粒径μm	区间%	累积%	粒径μm	区间%	累积%
0.100-0.111	0.00	0.00	1.000-1.115	0.00	0.00	10.00-11.15	2.02	15.30	100.0-111.5	3.53	91.07
0.111-0.124	0.00	0.00	1.115-1.245	0.00	0.00	11.15-12.45	2.25	17.55	111.5-124.5	2.99	94.06
0.124-0.138	0.00	0.00	1.245-1.389	0.03	0.03	12.45-13.89	2.42	19.97	124.5-138.9	2.32	96.38
0.138-0.155	0.00	0.00	1.389-1.550	0.07	0.10	13.89-15.50	2.62	22.59	138.9-155.0	1.68	98.06
0.155-0.173	0.00	0.00	1.550-1.730	0.14	0.24	15.50-17.30	2.79	25.38	155.0-173.0	1.08	99.14
0.173-0.193	0.00	0.00	1.730-1.930	0.19	0.43	17.30-19.30	2.90	28.28	173.0-193.0	0.56	99.70
0.193-0.215	0.00	0.00	1.930-2.154	0.26	0.69	19.30-21.54	3.03	31.31	193.0-215.4	0.23	99.93
0.215-0.240	0.00	0.00	2.154-2.404	0.31	1.00	21.54-24.04	3.14	34.45	215.4-240.4	0.07	100.00
0.240-0.268	0.00	0.00	2.404-2.682	0.36	1.36	24.04-26.82	3.22	37.67	240.4-268.2	0.00	100.00
0.268-0.299	0.00	0.00	2.682-2.993	0.42	1.78	26.82-29.93	3.35	41.02	268.2-299.3	0.00	100.00
0.299-0.334	0.00	0.00	2.993-3.340	0.49	2.27	29.93-33.40	3.48	44.50	299.3-334.0	0.00	100.00
0.334-0.372	0.00	0.00	3.340-3.727	0.54	2.81	33.40-37.27	3.66	48.16	334.0-372.7	0.00	100.00
0.372-0.415	0.00	0.00	3.727-4.159	0.63	3.44	37.27-41.59	3.87	52.03	372.7-415.9	0.00	100.00
0.415-0.464	0.00	0.00	4.159-4.641	0.73	4.17	41.59-46.41	4.10	56.13	415.9-464.1	0.00	100.00
0.464-0.517	0.00	0.00	4.641-5.179	0.85	5.02	46.41-51.79	4.33	60.46	464.1-517.9	0.00	100.00
0.517-0.577	0.00	0.00	5.179-5.779	0.97	5.99	51.79-57.79	4.53	64.99	517.9-577.9	0.00	100.00
0.577-0.644	0.00	0.00	5.779-6.449	1.11	7.10	57.79-64.48	4.67	69.66	577.9-644.9	0.00	100.00
0.644-0.719	0.00	0.00	6.449-7.196	1.26	8.36	64.48-71.95	4.70	74.36	644.9-719.6	0.00	100.00
0.719-0.803	0.00	0.00	7.196-8.029	1.45	9.81	71.95-80.30	4.65	79.01	719.6-803.0	0.00	100.00
0.803-0.896	0.00	0.00	8.029-8.961	1.62	11.43	80.30-89.61	4.43	83.44	803.0-896.1	0.00	100.00
0.896-1.000	0.00	0.00	8.961-10.00	1.85	13.28	89.61-100.0	4.10	87.54	896.1-1000	0.00	100.00

粒度分布详细表

用户信息区

仪器制造商: 丹东百特仪器有限公司 网址: www.bettersize.com 邮箱: services@bettersize.com 电话: 400-655-8837

系统状态 A:0-0-0-0-0-0-0-0-10-0-25-0-75-0-90-1-1 E:79-0-1-3-0

SW:01.01.08200.0 A6002 打印时间: 2024-04-16 11:16:58 工程名称: 连续运行 记录编号: 8 SOP: 炭素 测试方法: 激光法

百特设在各地的办事处



北京办事处



上海办事处



广州办事处



长沙办事处



深圳分公司



山东办事处



西安办事处



郑州办事处



徐州办事处

丹东百特仪器有限公司

地址：辽宁省丹东市临港产业园区金泉工业区甘泉路9号

销售热线：400-655-8837 服务热线：400-0388-017

邮箱：sales@battersize.com

网址：www.battersize.com



微信公众号：百特粒度仪