

衝壓不銹鋼潛水泵

STAMPING STAINLESS STEEL SUBMERSIBLE PUMP



联系我们

WWW.U-FLO.CN

营销中心 Marketing Center

ADD: 南京市中山东路288号新世纪广场A幢1006室 (210002)
Room 1006, Block A, New Century Plaza, 288# Zhongshan East Road, Nanjing
TEL: (86) 25-52231105 / 52230907 / 52230921 / 84846376 FAX: (86) 25-52230912

生产中心 Production Center

ADD: 南京市溧水经济开发区南区罗马工业园18号 (211200)
18# Rome Industry Park, Southern District, Lishui Economic Development Zone, Nanjing
TEL: (86) 25-56610801 / 56610802 / 56610803 / 56610805 / 56610815 FAX: (86) 25-56610806

销售服务热线: 400-100-8486 售后服务热线: 800-828-9695

南京方卓品牌设计 | www.njfad.com

VS/VN/VL
STAMPING SS
SUBMERSIBLE
PUMP

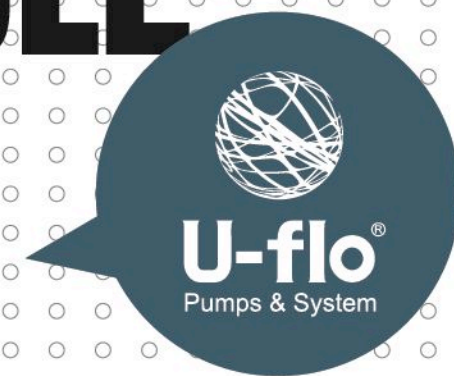

Contents 目录

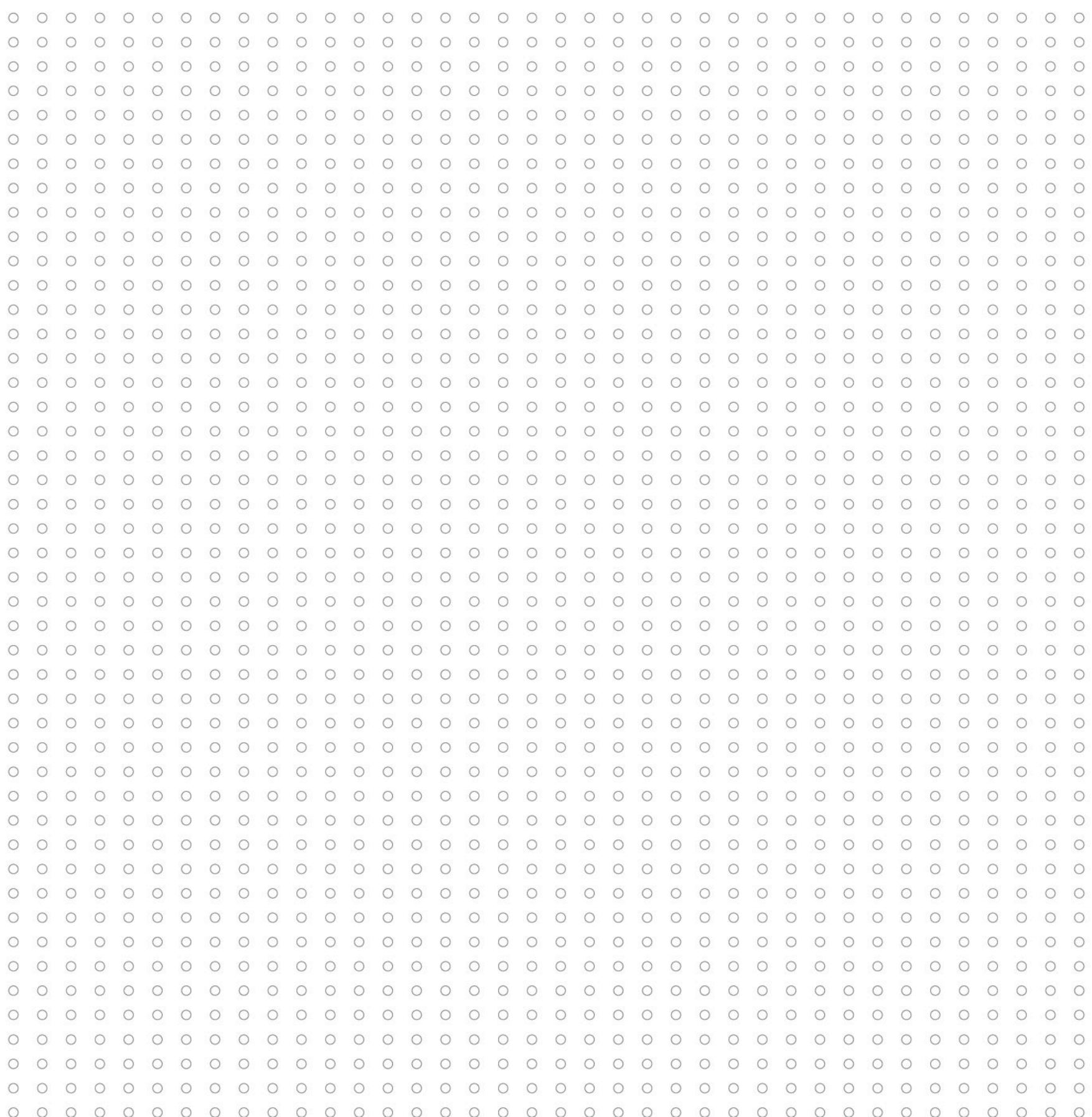

03/04 COMPANY PROFILE 公司介绍

U.S. U-flo
美国尤孚

05/57 PRODUCTS 产品介绍

STAMPING SS SUBMERSIBLE PUMP VS series
冲压不锈钢潜水泵 VS 系列
STAMPING SS SUBMERSIBLE PUMP VN series
冲压不锈钢潜水泵 VN 系列
STAMPING SS SUBMERSIBLE PUMP VL series
冲压不锈钢潜水泵 VL 系列

58/59 OTHERS 其他

TECHNOLOGY INDEX
技术索引

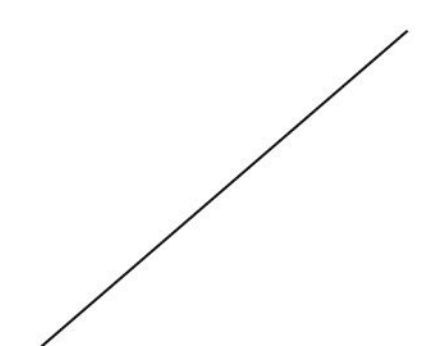



U-flo Pumps International LLC is a global water pump manufacturing and marketing company registered in Washington, USA. Our cooperated facilities are located in Italy, Japan, Taiwan and China. Our primary products include Deep-well Pumps, Above-ground Pumps, Sewage Pumps, Pumping Systems. They are widely used in power plants, paper mills, steel plants, agriculture irrigations, construction trades, industrial applications, mining operations, municipal utilities as well as oil/gas fields.

Integrity, Innovation, International

Since the first U-FLO water pump was manufactured, our people have been making unremitting endeavor to improve designs of the U-FLO water pump products. We apply the best industry practices and the best suitable materials for key components to the design and manufacturing of our pumps.

In addition to our state of art manufacturing facilities, we put a big effort on pump testing. Every product undergoes a rigorous testing and inspection process before being shipped to our customers. Our test facility incorporates a 12000 cubic meter (52,834 gallon) closed loop system with testing capacity of up to 600m³/h (2640GPM) with the maximum head of 200m (656ft), and 250 horsepower (dual voltages of 50Hz and 60Hz). Following a strict quality management system, all of our facilities are ISO 9001 and ISO 4001 certified.

Water is a vital part of our natural resources. While we always pursue the excellence of our products and services, we also take every step to promote environment-friendly and energy-saving solutions.

As a global pump manufacturer and supplier, U-FLO is committed to producing the finest water pumps in the world and continues to lead the way forward in the pumping industry.

U-FLO PUMPS INTERNATIONAL LLC是一家总部注册在美国华盛顿州的全球化水泵制造与销售公司。我们在意大利, 日本, 台湾和中国大陆地区均设有合作工厂。我们主要产品包括深井泵、地面泵、污水泵和供水设备。产品广泛应用于电厂、造纸厂、钢厂、农业灌溉、建筑、工业应用、矿山、市政以及油田领域。

诚信、创新、国际化

自第一台U-flo水泵出厂以来, 我们一直不懈努力, 致力于改进U-flo水泵的设计。我们以最高的行业要求和最佳材料设计和制造水泵。

在严抓工艺水平的同时, 我们还致力于水泵的测试。每一台水泵在出厂前均需要经过严格的测试和检验。我们的测试台含12000立方米(52,834加仑) 闭式循环系统, 最大测试流量达600m³/h(2640GPM),最高扬程为200m(656ft), 250马力(双电压50Hz、60Hz)。按照严格的质量管理体系, 我们所有的工厂均通过ISO9001和ISO14001认证。

水是自然资源的重要组成部分, 我们在追求卓越的产品和服务的同时, 亦在努力推广环保和节能解决方案。

作为全球水泵制造商和供应商, U-flo致力于生产全球最好的水泵, 成为水泵行业的领跑者。



Quality witness responsibility Technology create reliability

品质见证责任 专业成就信赖!



Design & production 设计和制造

Design and production are all made internally at U-flo's facilities, with a quality and process systems in accordance to the ISO9001 standards; as a further results of its environmental orientation, U-flo, in the 2011, got the ambitious ISO14001 Certificate proving that its production processes comply with the very strict rules imposed by the ISO14001 Certificate.

U-flo 自主设计和制造，质量及生产系统符合 ISO9001 标准。更因为 U-flo 准确的环境定位，2011 年获得 ISO14001 认证，充分证明生产过程符合 ISO14001 标准。

Application 产品应用范围

VS

Irrigation / Domestic and industrial applications / Water supply / Pressurizing water systems / Deep well water pumping / Fire-fighting systems / Mining / Water pumping of water works
灌溉 / 民用和工业应用 / 供水 / 增压水系统 / 深井取水 / 消防系统 / 矿山开采
自来水厂取水

VN

Pressure boost for water supply / Rainwater distribution / Agriculture irrigation & sprinkling system / Cleaning system / Fountain / Other industrial applications
供水增压 / 雨水输送 / 农业灌溉和喷洒系统 / 清洗系统 / 喷泉 / 其他工业用途

VL

Boost / Water supply / Deep-well pumping / Rainwater delivery / Cleaning system / Agricultural irrigation & sprinkling system / Fountain and water entertainment project
增压 / 供水 / 深井抽水 / 雨水输送 / 清洗系统 / 农业灌溉喷洒系统 / 喷泉及水娱乐项目

U-FLO reserves the right to make modifications without notice.

U-FLO 有权对产品进行修改，恕不另行通知。



STAMPING SS SUBMERSIBLE PUMP VS SERIES

STAMPING STAINLESS STEEL SUBMERSIBLE PUMP

VS

I、Introduction

The new VS series stamping stainless steel submersible pump are greatly improved in design technique. Adopt advanced laser cutting and welding process ensure high efficiency and compact structure.

最新的VS系列冲压不锈钢潜水泵，在设计技术方面做了很大的改进，采用最先进的激光切割，激光焊接工艺加工制作，水泵效率高，结构更加小巧紧凑。



STAMPING SS SUBMERSIBLE PUMP VS SERIES / 冲压不锈钢潜水泵 VS系列

II、FEATURES VS特点

- 1、All pump parts are made of stainless steel ensure excellent corrosion resistance, wear resistance and a long failure-free service life.
- 2、All pump parts comply with water quality hygiene detection which prevents the pollution of the transferred water.
- 3、The efficiency is up to 84%. High efficiency pump reduces energy consumption, therefore reduce pump operating cost and take less time to recovering initial cost.
- 4、Adopt advanced casing technology ensure stamping, laser welding etc. The durable structure satisfies complicated working environment.
- 5、All wearing parts are easy to replace without special tools.

- 1、所有水泵部件均由不锈钢材料制成，保证了极佳的耐腐蚀性，抗磨性，和长期无故障的工作。
- 2、水泵所有部件均通过水质卫生检测保证输送的水无污染。
- 3、效率可达84%，高效率的水泵意味着更低的能量消耗，从而降低水泵运行成本，以便在更短的时间收回初始成本。
- 4、采用先进的冲压，激光焊接等技术生产壳体。水泵坚固耐用，能够应付复杂的工作状态。
- 5、所有易损件均容易更换，且无需特别工具。

III、TECHNICAL SPECIFICATION 技术参数

Flow up to: 280m ³ /h	流量可达: 280 m ³ /h
Head up to: 550 m	扬程可达: 550 m
Maximum pump diameter: 247 mm	水泵最大直径: 247 mm
Laser welding, high efficiency, energy saving	激光焊接，效率高，节能
T>90℃ available upon request	最大水温: T>90℃可提供
According to the NEMA standard	符合NEMA标准
Maximum starts/hour: 20	每小时最大启动次数: 20
Maximum sand density in water: 50g/m ³	最大含沙量: 50g/m ³

IV、MODEL DESCRIPTION 型号说明

VS N 13 / 17

Number of stages	水泵级数
Nominal flow(m ³ /h)	额定流量(m ³ /h)
316 Material	316材质
304 Material	304材质

VS

VS 1

VS 2

VS 3

VS 5

VS 8

VS 13

VS 17

VS 30

VS 45

VS 60

VS 75

VS 95

VS 125

VS 160

VS 210

VN

VN 3

VN 5

VN 9

VL

VL 3

VL 5

VL 9

OTHERS

STAMPING SS SUBMERSIBLE PUMP

VS SERIES / 冲压不锈钢潜水泵 VS系列

V、PUMP CONSTRUCTION & MATERIAL 水泵结构及材质

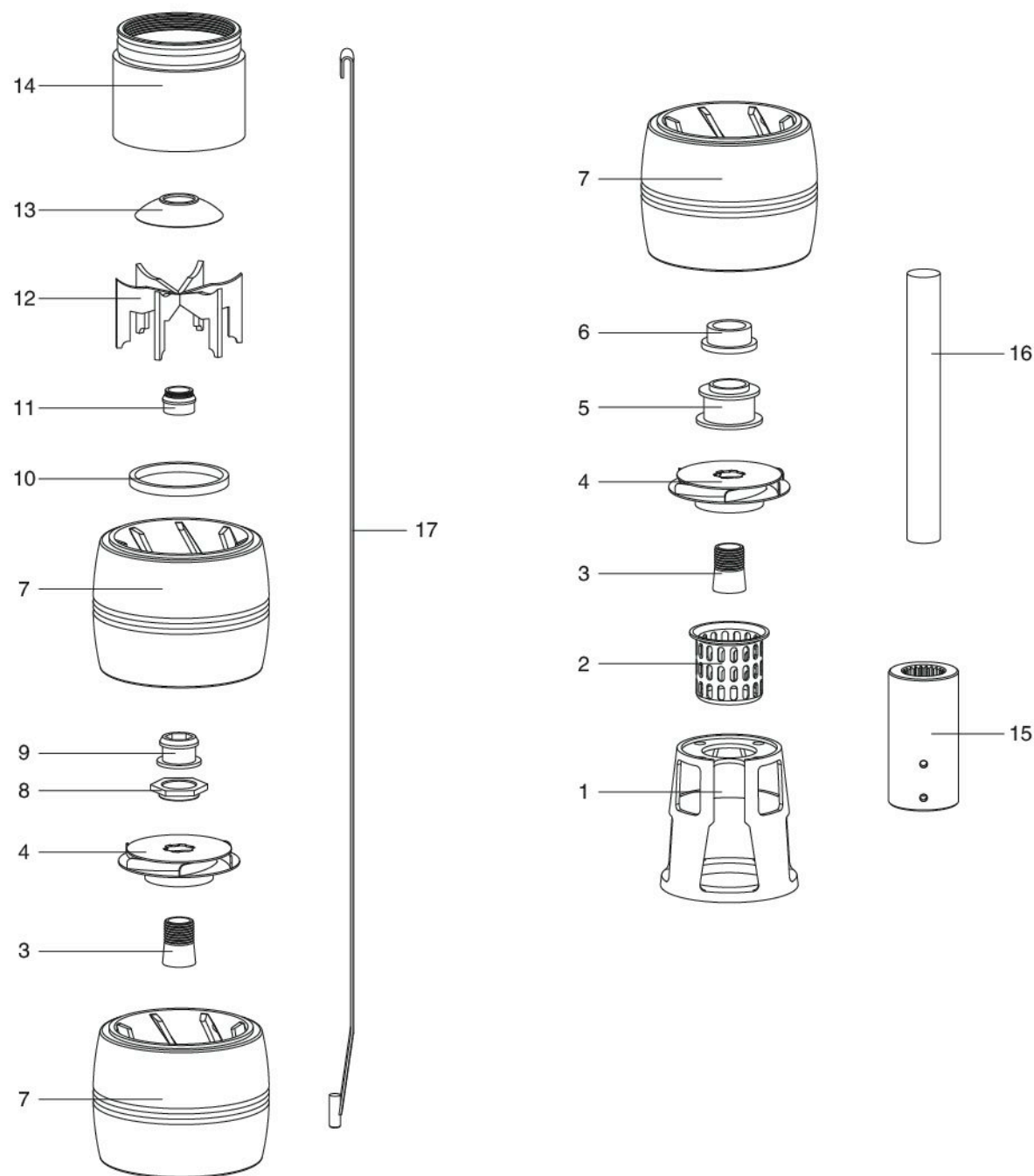

STAMPING SS SUBMERSIBLE PUMP

VS SERIES / 冲压不锈钢潜水泵 VS系列

PUMP CONSTRUCTION & MATERIAL 水泵结构及材质

	DESCRIPTION	MATERIAL	VS/VSN
1	Suction bowl	Stainless steel 304/316	
2	Strainer	Stainless steel 304/316	
3	Impeller lock collet	Stainless steel 304/316	
4	Impeller	Stainless steel 304/316	
5	Thrust nut	Stainless steel 304/316	
6	Up thrust bearing	BRONZE/S.S	
7	Diffuser	Stainless steel 304/316	
8	Impeller nut	Stainless steel 304/316	
9	Bowl Bearing	Stainless steel 304/316	
10	Valve seal	HNBR	
11	Top bearing	HNBR	
12	Valve holder	Stainless steel 304/316	
13	Valve	Stainless steel 304/316	
14	Valve Bowl	Stainless steel 304/316	
15	Shaft coupling	Stainless steel 304/316	
16	Shaft	Stainless steel 304/316	
17	Strap	Stainless steel 304/316	

	组件	材质	VS/VSN
1	吸入口导壳	不锈钢 304/316	
2	滤网	不锈钢 304/316	
3	锁套	不锈钢 304/316	
4	叶轮	不锈钢 304/316	
5	止推螺母	不锈钢 304/316	
6	止推轴承	青铜 / 不锈钢	
7	导叶	不锈钢 304/316	
8	叶轮螺母	不锈钢 304/316	
9	滚转轴承	不锈钢 304/316	
10	阀门密封	HNBR	
11	上轴承	HNBR	
12	阀座	不锈钢 304/316	
13	阀门	不锈钢 304/316	
14	阀箱	不锈钢 304/316	
15	联轴器	不锈钢 304/316	
16	轴	不锈钢 304/316	
17	拉杆	不锈钢 304/316	

VS

VS 1

VS 2

VS 3

VS 5

VS 8

VS 13

VS 17

VS 30

VS 45

VS 60

VS 75

VS 95

VS 125

VS 160

VS 210

VN

VN 3

VN 5

VN 9

VL

VL 3

VL 5

VL 9

OTHERS

STAMPING SS SUBMERSIBLE PUMP

4" VS SERIES / 冲压不锈钢潜水泵 VS系列

TECHNICAL SPECIFICATION 技术参数

MODEL 型号	MOTOR 电机			l/min	0.00	5.00	10.00	15.00	20.00	25.00
	[Kw]	[Hp]	[A]		l/sec	0.00	0.08	0.17	0.25	0.33
				m³/h	0.0	0.3	0.6	0.9	1.2	1.5
VS1/9	0.37	1/2	1.6	"TOTAL	51	51	48	40	30	18
VS1/14	0.37	1/2	1.6	MANOM	80	77	68	56	40	26
VS1/18	0.55	3/4	1.9	ETRIC	102	100	92	78	60	38
VS1/21	0.55	3/4	1.9	HEAD	118	116	105	87	67	42
VS1/28	0.75	1	2.4	HMT扬程	159	152	137	116	89	57
VS1/36	1.1	1.5	3.4	[M]"	207	199	181	150	114	73
VS1/42	1.1	1.5	3.4		240	229	206	171	129	81
VS1/50	1.5	2	4.4		284	268	240	197	132	90

OVERALL DIMENSIONS & WEIGHT 尺寸和重量										
MODEL 型号	A	B	C	DN	H	M	Max	W	P	V
	[mm]	[mm]	[mm]	[mm]	[mm]	[mm]	[mm]	[kg]	[kg]	[m/sec]
VS1/9	596	354	242	1"1/4	600	93	98	8.2	11.3	0.1
VS1/14	701	459	242	1"1/4	600	93	98	8.2	12.2	0.1
VS1/18	813	543	270	1"1/4	600	93	98	9.5	11.2	0.1
VS1/21	876	606	270	1"1/4	600	93	98	9.5	14.7	0.1
VS1/28	1051	753	298	1"1/4	600	93	98	10.9	17.5	0.1
VS1/36	1244	946	298	1"1/4	600	93	98	10.9	19.5	0.1
VS1/42	1370	1072	298	1"1/4	600	93	98	10.9	20.7	0.1
VS1/50	1586	1240	346	1"1/4	600	93	98	12.7	24	0.1

W: Motor weight P: Pump weight(Include motor)
W: 电机重量 P: 水泵总重(含电机)

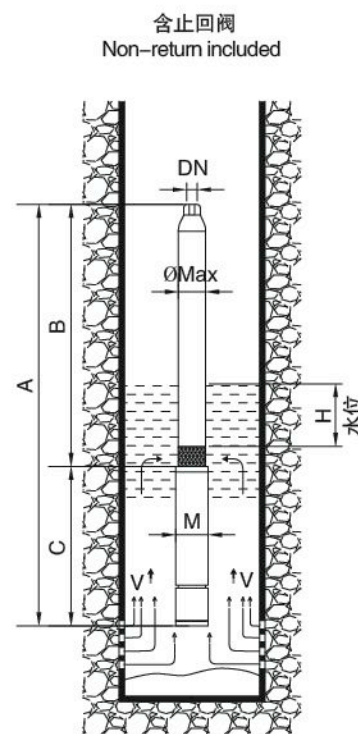

STAMPING SS SUBMERSIBLE PUMP

4" VS SERIES / 冲压不锈钢潜水泵 VS系列

PERFORMANCE CURVE CHART 性能曲线图

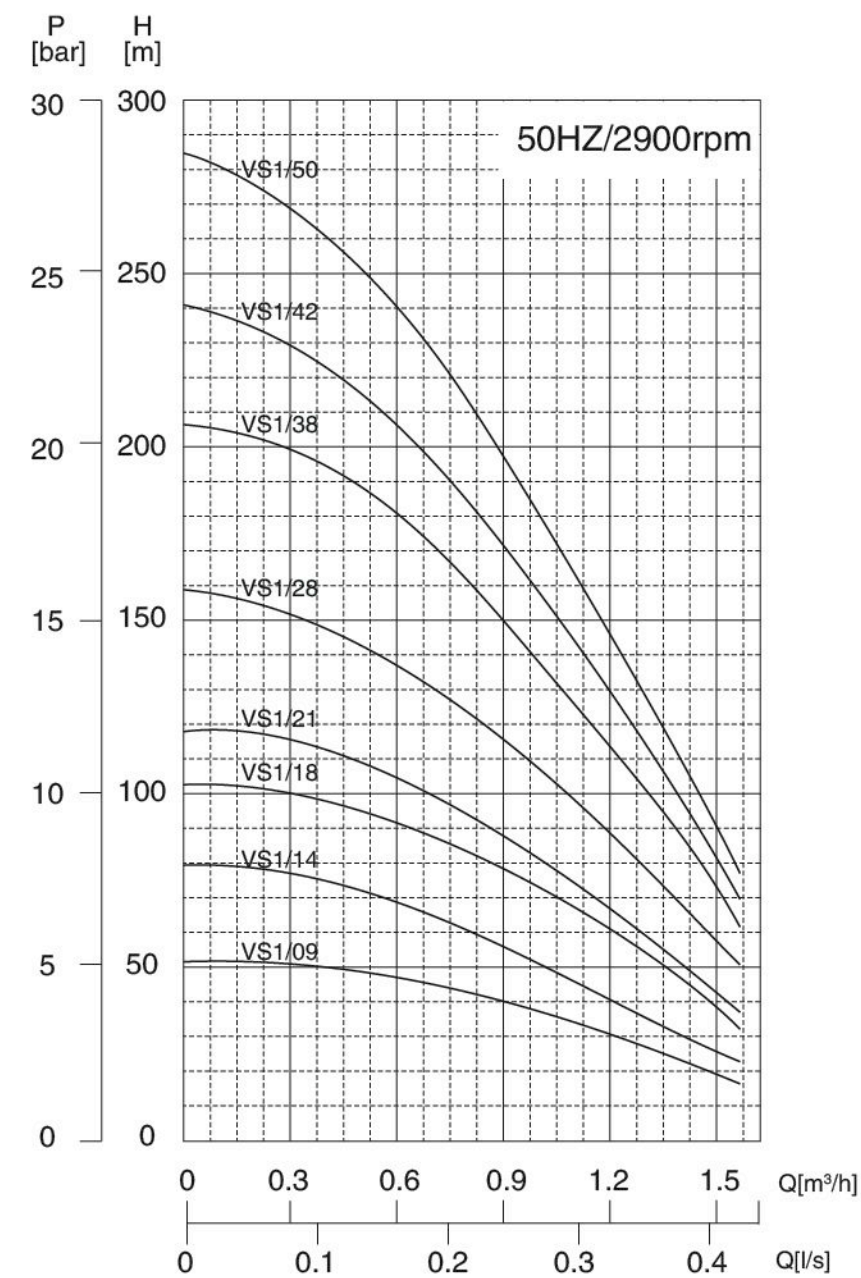

- VS
- VS 1
- VS 2
- VS 3
- VS 5
- VS 8
- VS 13
- VS 17
- VS 30
- VS 45
- VS 60
- VS 75
- VS 95
- VS 125
- VS 160
- VS 210
- VN
- VN 3
- VN 5
- VN 9
- VL
- VL 3
- VL 5
- VL 9
- OTHERS

STAMPING SS SUBMERSIBLE PUMP

4" VS SERIES / 冲压不锈钢潜水泵 VS系列

TECHNICAL SPECIFICATION 技术参数

MODEL 型号	MOTOR 电机			l/min	0.00	10.00	20.00	30.00	40.00	45.00
	[Kw]	[Hp]	[A]		l/sec	0.00	0.17	0.33	0.50	0.67
				m³/h	0.0	0.6	1.2	1.8	2.4	2.7
VS2/6	0.37	1/2	1.6		34	33	31	26	16	9
VS2/9	0.37	1/2	1.6		52	51	46	36	22	13
VS2/13	0.55	3/4	1.9		70	68	60	47	27	16
VS2/18	0.75	1	2.4	TOTAL MANOM ETRIC HEAD HMT 扬程 [M]	107	102	90	72	45	27
VS2/23	1.1	1.5	3.4		133	130	117	95	62	36
VS2/28	1.5	2	4.4		168	162	143	114	73	45
VS2/33	1.5	2	4.4		195	187	165	130	80	49
VS2/40	2.2	3	5.9		239	227	201	160	102	65
VS2/48	2.2	3	5.9		288	272	234	180	110	75

OVERALL DIMENSIONS & WEIGHT 尺寸和重量

MODEL 型号	A	B	C	DN	H	M	Max	W	P	V
	[mm]	[mm]	[mm]	[mm]	[mm]	[mm]	[mm]	[kg]	[kg]	[m/sec]
VS2/6	533	291	242	1"1/4	600	93	98	8.2	10.8	0.1
VS2/9	596	354	242	1"1/4	600	93	98	8.2	11.4	0.1
VS2/13	708	438	270	1"1/4	600	93	98	9.5	13.5	0.1
VS2/18	841	543	298	1"1/4	600	93	98	10.9	16	0.1
VS2/23	956	658	298	1"1/4	600	93	98	10.9	17.1	0.1
VS2/28	1099	753	346	1"1/4	600	93	98	12.7	19.7	0.1
VS2/33	1204	858	346	1"1/4	600	93	98	12.7	20.8	0.1
VS2/40	1437	1030	407	1"1/4	600	93	98	15.9	26.3	0.1
VS2/48	1605	1198	407	1"1/4	600	93	98	15.9	28	0.1

W: Motor weight P: Pump weight(Include motor)
W: 电机重量 P: 水泵总重(含电机)

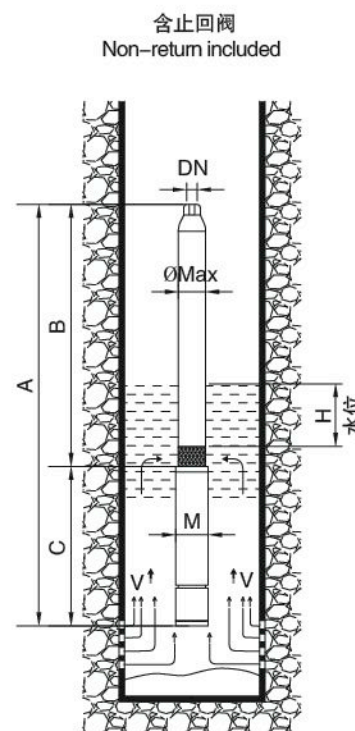

STAMPING SS SUBMERSIBLE PUMP

4" VS SERIES / 冲压不锈钢潜水泵 VS系列

PERFORMANCE CURVE CHART 性能曲线图

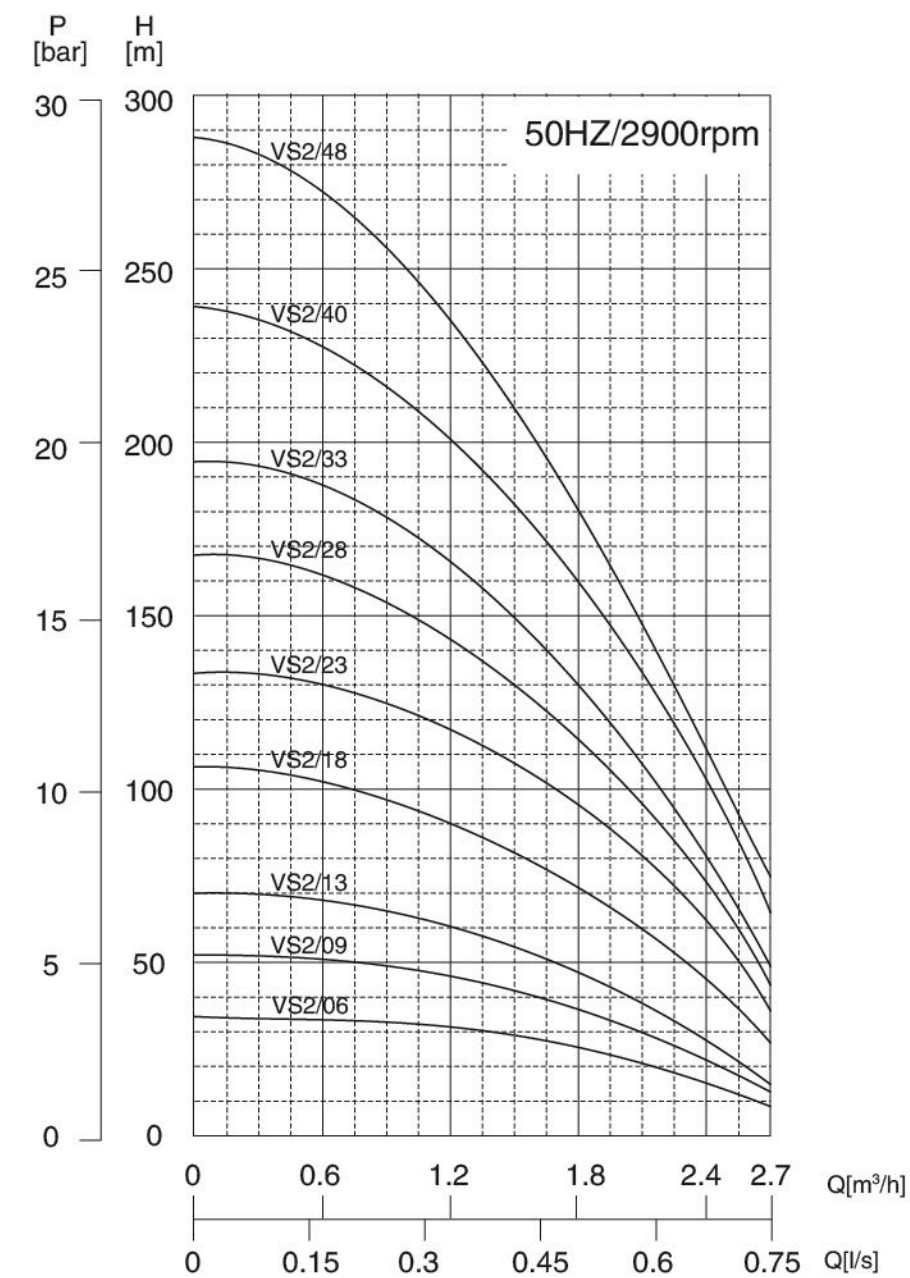

- VS
- VS 1
- VS 2
- VS 3
- VS 5
- VS 8
- VS 13
- VS 17
- VS 30
- VS 45
- VS 60
- VS 75
- VS 95
- VS 125
- VS 160
- VS 210
- VN
- VN 3
- VN 5
- VN 9
- VL
- VL 3
- VL 5
- VL 9
- OTHERS

STAMPING SS SUBMERSIBLE PUMP

4" VS SERIES / 冲压不锈钢潜水泵 VS系列

TECHNICAL SPECIFICATION 技术参数

MODEL 型号	MOTOR 电机			TOTAL MANOMETRIC HEAD HMT 扬程 [M]	l/min	0.00	10.00	20.00	30.00	40.00	50.00	60.00	70.00
	[Kw]	[Hp]	[A]		l/sec	0.00	0.17	0.33	0.50	0.67	0.83	1.00	1.17
					m³/h	0.0	0.6	1.2	1.8	2.4	3.0	3.6	4.2
VS3/6	0.37	0.5	1.6		35	34	32	31	29	25	19	10	
VS3/9	0.55	3/4	1.9		56	53	51	49	45	39	30	17	
VS3/12	0.75	1	2.4		74	70	68	65	60	52	40	26	
VS3/15	1.1	1.5	3.4		92	88	85	83	77	68	54	32	
VS3/18	1.1	1.5	3.4		111	106	102	98	92	81	63	39	
VS3/22	1.5	2	4.4		132	128	124	118	110	95	74	46	
VS3/25	1.5	2	4.4		150	144	138	131	120	103	80	52	
VS3/29	2.2	3	5.9		177	170	164	155	142	122	93	55	
VS3/33	2.2	3	5.9		200	192	184	173	157	135	103	62	
VS3/39	3	4	8.3		238	230	224	214	197	171	132	80	
VS3/45	3	4	8.3		275	266	257	244	224	191	148	92	
VS3/52	4	5.5	10		319	307	294	278	254	216	165	104	

OVERALL DIMENSIONS & WEIGHT 尺寸和重量

MODEL 型号	A [mm]	B [mm]	C [mm]	DN [mm]	H [mm]	M [mm]	Max [mm]	W [kg]	P [kg]	V [m/sec]
VS3/6	533	291	242	1"1/4	600	93	98	8.2	10.8	0.1
VS3/9	624	354	270	1"1/4	600	93	98	9.5	12.6	0.1
VS3/12	715	417	298	1"1/4	600	93	98	10.9	14.6	0.1
VS3/15	778	480	298	1"1/4	600	93	98	10.9	15.2	0.1
VS3/18	841	543	298	1"1/4	600	93	98	10.9	15.8	0.1
VS3/22	973	627	346	1"1/4	600	93	98	12.7	18.4	0.1
VS3/25	1036	690	346	1"1/4	600	93	98	12.7	19	0.1
VS3/29	1181	774	407	1"1/4	600	93	98	15.9	23	0.1
VS3/33	1265	858	407	1"1/4	600	93	98	15.9	23.8	0.1
VS3/39	1573	1009	564	1"1/4	600	93	98	25	34.7	0.1
VS3/45	1699	1135	564	1"1/4	600	93	98	25	35.8	0.1
VS3/52	1915	1282	633	1"1/4	600	93	98	27.7	40.2	0.1

W: Motor weight P: Pump weight(Include motor)
W: 电机重量 P: 水泵总重(含电机)

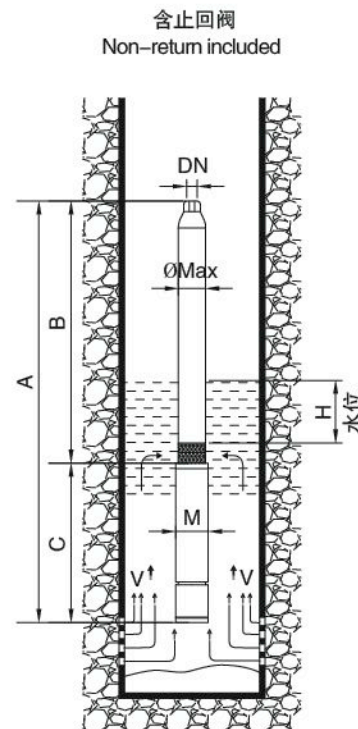

STAMPING SS SUBMERSIBLE PUMP

4" VS SERIES / 冲压不锈钢潜水泵 VS系列

PERFORMANCE CURVE CHART 性能曲线图

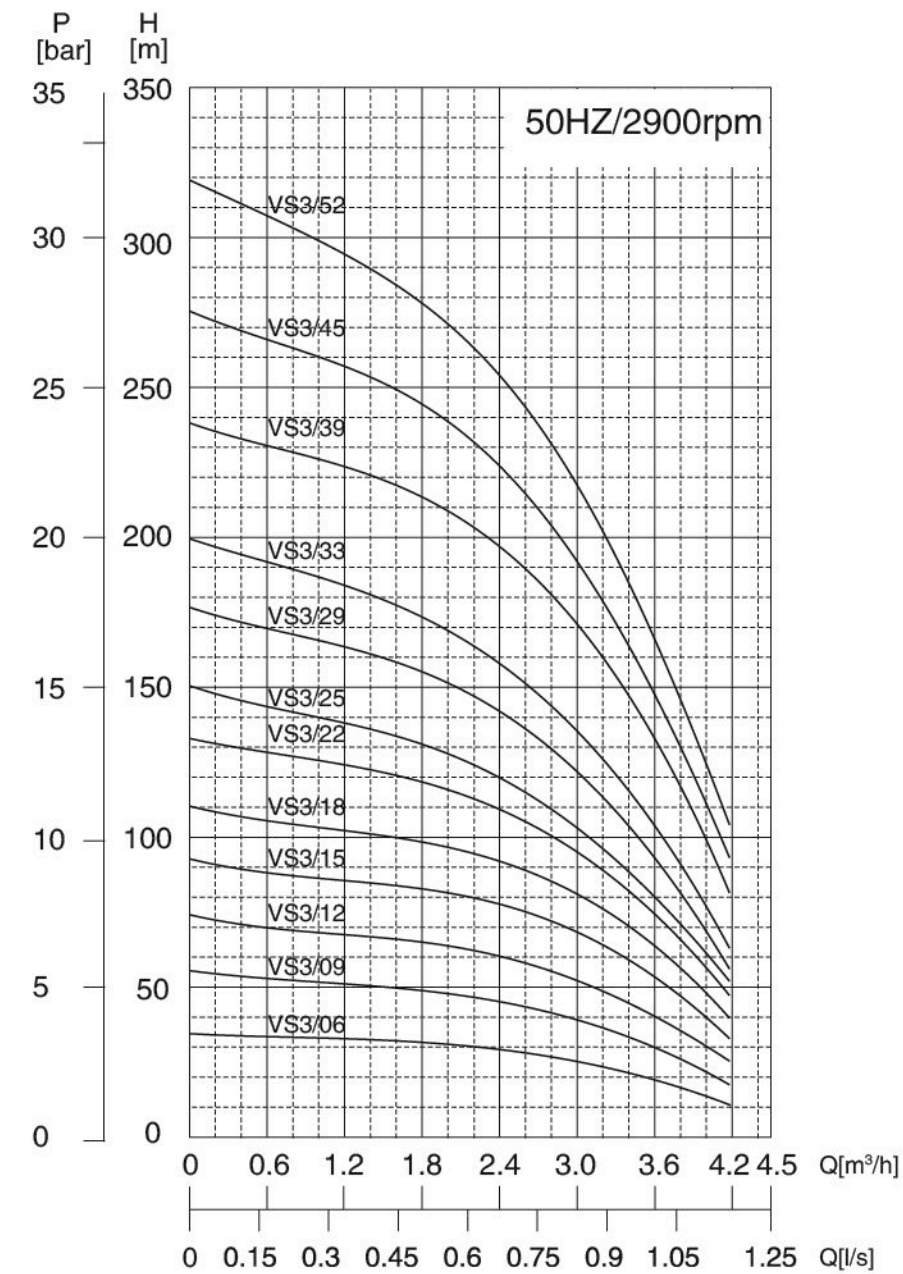

- VS
- VS 1
- VS 2
- VS 3
- VS 5
- VS 8
- VS 13
- VS 17
- VS 30
- VS 45
- VS 60
- VS 75
- VS 95
- VS 125
- VS 160
- VS 210
- VN
- VN 3
- VN 5
- VN 9
- VL
- VL 3
- VL 5
- VL 9
- OTHERS

STAMPING SS SUBMERSIBLE PUMP

4" VS SERIES / 冲压不锈钢潜水泵 VS系列

TECHNICAL SPECIFICATION 技术参数

MODEL 型号	MOTOR 电机			TOTAL MANOMETRIC HEAD HMT 扬程 [M]	0.00	20.00	40.00	60.00	80.00	100.00	
	[Kw]	[Hp]	[A]		l/min	0.00	0.33	0.67	1.00	1.33	1.67
					l/sec	0.00	0.33	0.67	1.00	1.33	1.67
					m³/h	0.0	1.2	2.4	3.6	4.8	6.0
VS5/4	0.37	0.5	1.6			23	22	20	18	16	10
VS5/6	0.55	3/4	1.9			37	34	32	31	28	20
VS5/8	0.75	1	2.4			51	46	44	40	34	24
VS5/12	1.1	1.5	3.4			78	71	67	62	54	40
VS5/17	1.5	2	4.4			108	100	93	83	70	50
VS5/21	2.2	3	5.9			132	124	116	105	89	65
VS5/25	2.2	3	5.9			157	146	135	120	103	76
VS5/33	3	4	8.3			209	193	180	165	140	100
VS5/38	4	5.5	10			241	226	210	189	156	110
VS5/44	4	5.5	10			281	256	234	209	172	120
VS5/52	5.5	7.5	14			331	307	285	258	216	152

OVERALL DIMENSIONS & WEIGHT 尺寸和重量

MODEL 型号	A [mm]	B [mm]	C [mm]	DN [mm]	H [mm]	M [mm]	Max [mm]	W [kg]	P [kg]	V [m/sec]
VS5/4	491	249	242	1"1/2	600	93	98	8.2	10.4	0.2
VS5/6	561	291	270	1"1/2	600	93	98	9.5	12.1	0.2
VS5/8	631	333	298	1"1/2	600	93	98	10.9	13.8	0.2
VS5/12	715	417	298	1"1/2	600	93	98	10.9	14.6	0.2
VS5/17	868	522	346	1"1/2	600	93	98	12.7	17.4	0.2
VS5/21	1013	606	407	1"1/2	600	93	98	15.9	21.5	0.2
VS5/25	1097	690	407	1"1/2	600	93	98	15.9	22.3	0.2
VS5/33	1422	858	564	1"1/2	600	93	98	25	32.8	0.2
VS5/38	1616	988	628	1"1/2	600	93	98	27.7	37.4	0.2
VS5/44	1742	1114	628	1"1/2	600	93	98	27.7	38.7	0.2
VS5/52	1998	1282	716	1"1/2	600	93	98	31.8	44.8	0.2

W: Motor weight P: Pump weight(Include motor)
W: 电机重量 P: 水泵总重(含电机)

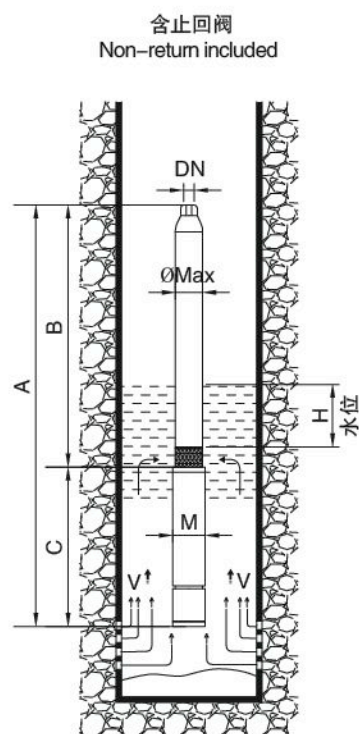

STAMPING SS SUBMERSIBLE PUMP

4" VS SERIES / 冲压不锈钢潜水泵 VS系列

PERFORMANCE CURVE CHART 性能曲线图

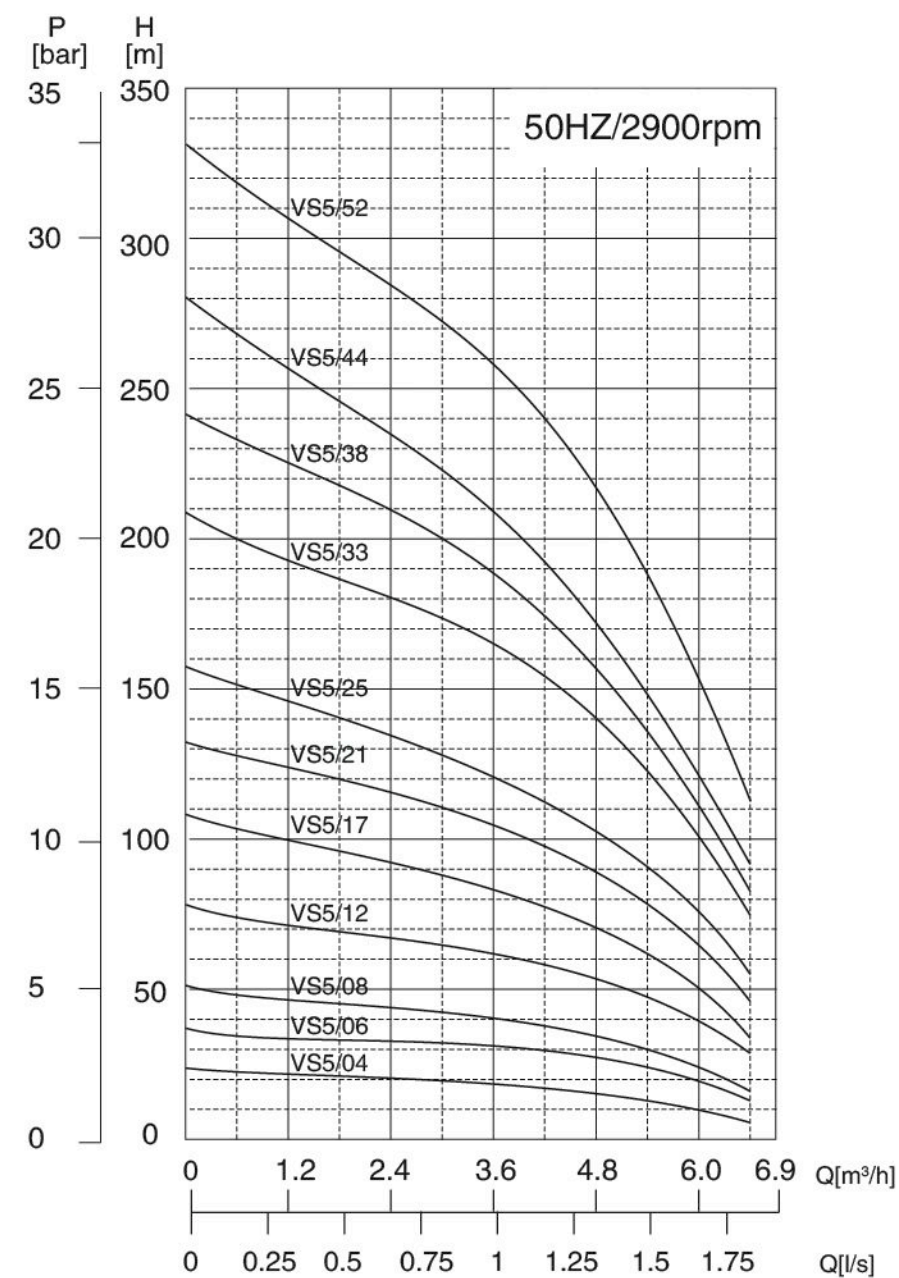

- VS
- VS 1
- VS 2
- VS 3
- VS 5
- VS 8
- VS 13
- VS 17
- VS 30
- VS 45
- VS 60
- VS 75
- VS 95
- VS 125
- VS 160
- VS 210
- VN
- VN 3
- VN 5
- VN 9
- VL
- VL 3
- VL 5
- VL 9
- OTHERS

STAMPING SS SUBMERSIBLE PUMP

4" VS SERIES / 冲压不锈钢潜水泵 VS系列

TECHNICAL SPECIFICATION 技术参数

MODEL 型号	MOTOR 电机			TOTAL MANOMETRIC HEAD HMT 扬程 [M]	0.00	33.33	66.67	100.00	133.33	166.67
	[Kw]	[Hp]	[A]		l/min	l/sec	m ³ /h			
VS8/5	0.75	1	2.4	28	27	25	23	20	14	
VS8/7	1.1	1.5	3.4	40	37	35	32	28	20	
VS8/10	1.5	2	4.4	58	52	48	46	40	29	
VS8/12	2.2	3	5.9	69	63	59	56	48	35	
VS8/15	2.2	3	5.9	84	77	73	68	59	52	
VS8/18	3	4	8.3	100	93	87	83	72	63	
VS8/21	4	5.5	10	117	106	98	92	80	70	
VS8/25	4	5.5	10	141	127	116	108	94	82	
VS8/30	5.5	7.5	14	170	153	145	136	118	104	
VS8/37	5.5	7.5	14	208	187	175	164	142	124	
VS8/44	7.5	10	17.4	250	228	215	202	179	160	
VS8/50	7.5	10	17.4	300	277	258	240	218	201	

OVERALL DIMENSIONS & WEIGHT 尺寸和重量

MODEL 型号	A [mm]	B [mm]	C [mm]	DN [mm]	H [mm]	M [mm]	Max [mm]	W [kg]	P [kg]	V [m/sec]
VS8/5	709	411	298	2"	600	93	98	10.9	15.4	0.2
VS8/7	793	495	298	2"	600	93	98	10.9	16.3	0.2
VS8/10	967	621	346	2"	600	93	98	12.7	19.6	0.2
VS8/12	1112	705	407	2"	600	93	98	15.9	23.6	0.2
VS8/15	1238	831	407	2"	600	93	98	15.9	25.3	0.2
VS8/18	1521	957	564	2"	600	93	98	25	36.1	0.2
VS8/21	1711	1083	628	2"	600	93	98	27.7	40	0.2
VS8/25	1879	1251	628	2"	600	93	98	27.7	41.9	0.2
VS8/30	2177	1461	716	2"	600	93	98	31.8	48.5	0.2
VS8/37	2471	1755	716	2"	600	93	98	31.8	52	0.2
VS8/44	2822	2049	773	2"	600	93	98	34.1	70.5	0.2
VS8/50	3071	2298	773	2"	600	93	98	34.1	86.9	0.2

W: Motor weight P: Pump weight(Include motor)
W: 电机重量 P: 水泵总重(含电机)

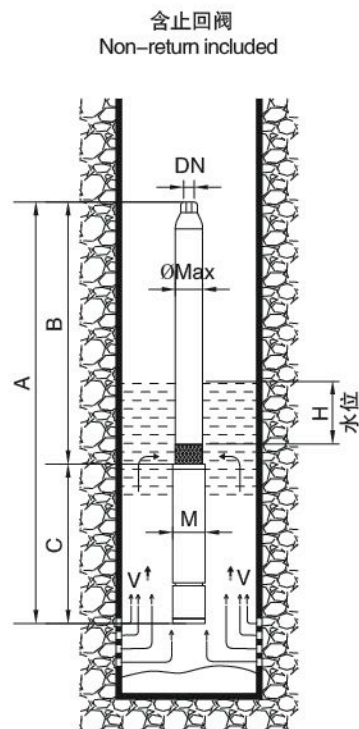

STAMPING SS SUBMERSIBLE PUMP

4" VS SERIES / 冲压不锈钢潜水泵 VS系列

PERFORMANCE CURVE CHART 性能曲线图

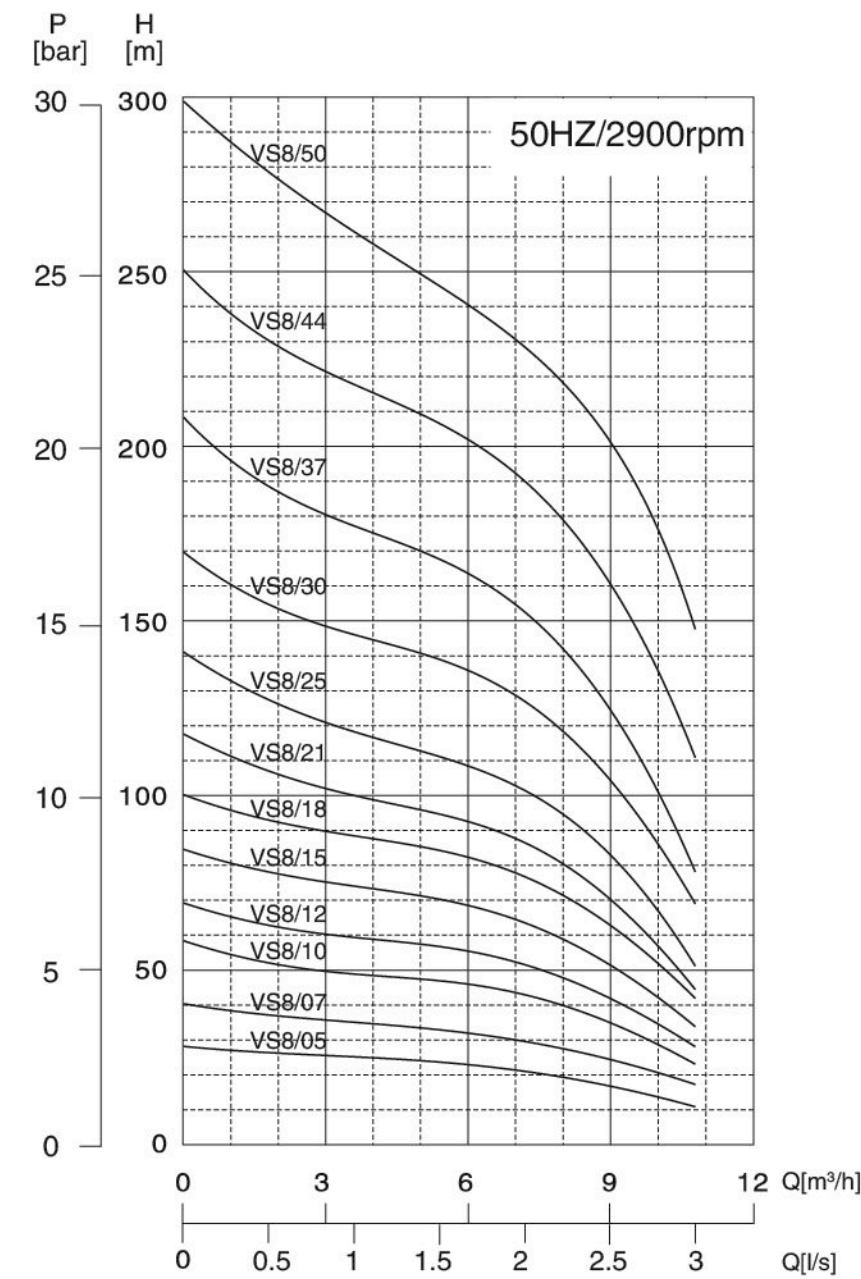

- VS
- VS 1
- VS 2
- VS 3
- VS 5
- VS 8**
- VS 13
- VS 17
- VS 30
- VS 45
- VS 60
- VS 75
- VS 95
- VS 125
- VS 160
- VS 210
- VN
- VN 3
- VN 5
- VN 9
- VL
- VL 3
- VL 5
- VL 9
- OTHERS

STAMPING SS SUBMERSIBLE PUMP

6" VS SERIES / 冲压不锈钢潜水泵 VS系列

TECHNICAL SPECIFICATION 技术参数

MODEL 型号	MOTOR 电机			TOTAL MANOMETRIC HEAD HMT 扬程 [m]	0	100	133	166	200	233	266
	[Kw]	[Hp]	[A]		l/min	100	133	166	200	233	266
VS 13/9	4.0	5.5	9.5	94	88	82	74	70	65	53	
VS 13/12	5.5	7.5	12.8	132	123	115	104	98	91	74	
VS 13/17	7.5	10	16.3	179	167	156	141	133	123	101	
VS 13/21	11	15	24	226	211	197	178	168	155	127	
VS 13/24	11	15	24	263	246	230	208	195	181	148	
VS 13/28	15	20	32	310	290	271	245	230	214	175	
VS 13/33	15	20	32	357	334	312	283	265	246	201	
VS 13/37	18.5	25	40	395	369	345	312	293	272	223	
VS 13/41	18.5	25	40	442	413	386	350	328	304	249	
VS 13/45	22	30	47	489	457	427	387	363	337	276	
VS 13/49	30	40	64.1	527	492	459	416	391	362	297	

OVERALL DIMENSIONS & WEIGHT 尺寸和重量

MODEL 型号	A [mm]	B [mm]	C [mm]	DN [mm]	H [mm]	M [mm]	Max [mm]	W [kg]	P [kg]	V [m/sec]
VS 13/9	1412	798	614	2"1/2	800	93	131	23	36	0.2
VS 13/12	1663	979	684	2"1/2	800	93	131	27	47	0.2
VS 13/17	2062	1298	764	2"1/2	800	93	131	31	54	0.2
VS 13/21	2270	1540	730	2"1/2	800	145	142	53	72	0.2
VS 13/24	2451	1721	730	2"1/2	800	145	142	53	78	0.2
VS 13/28	2748	1963	785	2"1/2	800	145	142	59	88	0.2
VS 13/33	3051	2266	785	2"1/2	800	145	142	59	99	0.2
VS 13/37	3368	2508	860	2"1/2	800	145	142	66	109	0.2
VS 13/41	3978	3118	860	2"1/2	800	145	142	66	114	0.2
VS 13/45	4278	3358	920	2"1/2	800	145	142	73	124	0.2
VS 13/49	4648	3598	1050	2"1/2	800	145	142	85	137	0.2

W: Motor weight P: Pump weight(Include motor)
W: 电机重量 P: 水泵总重(含电机)

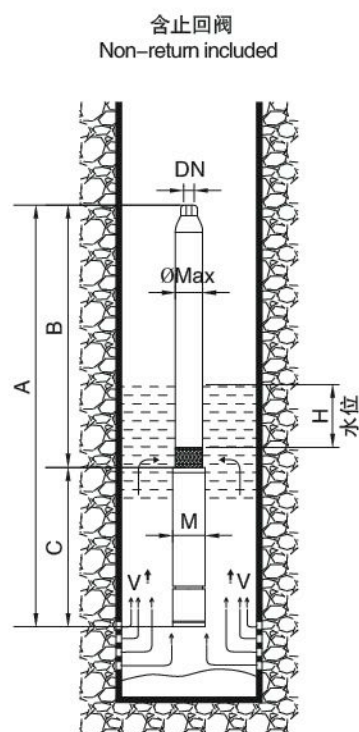

STAMPING SS SUBMERSIBLE PUMP

6" VS SERIES / 冲压不锈钢潜水泵 VS系列

PERFORMANCE CURVE CHART 性能曲线图

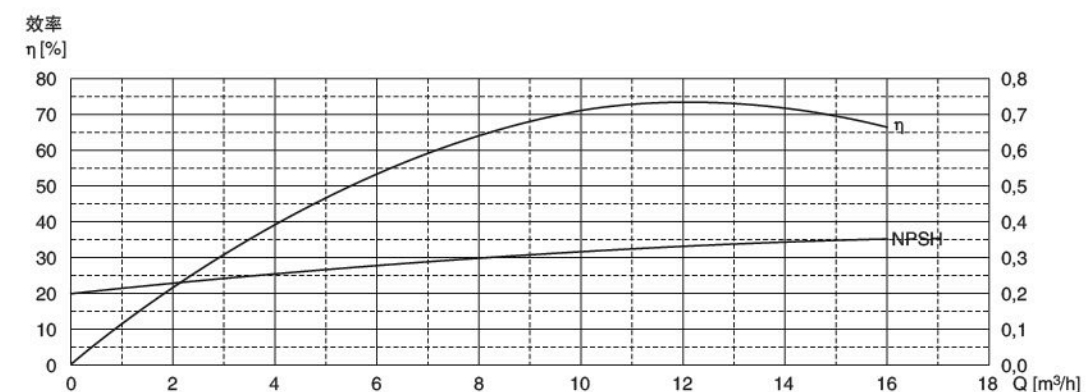
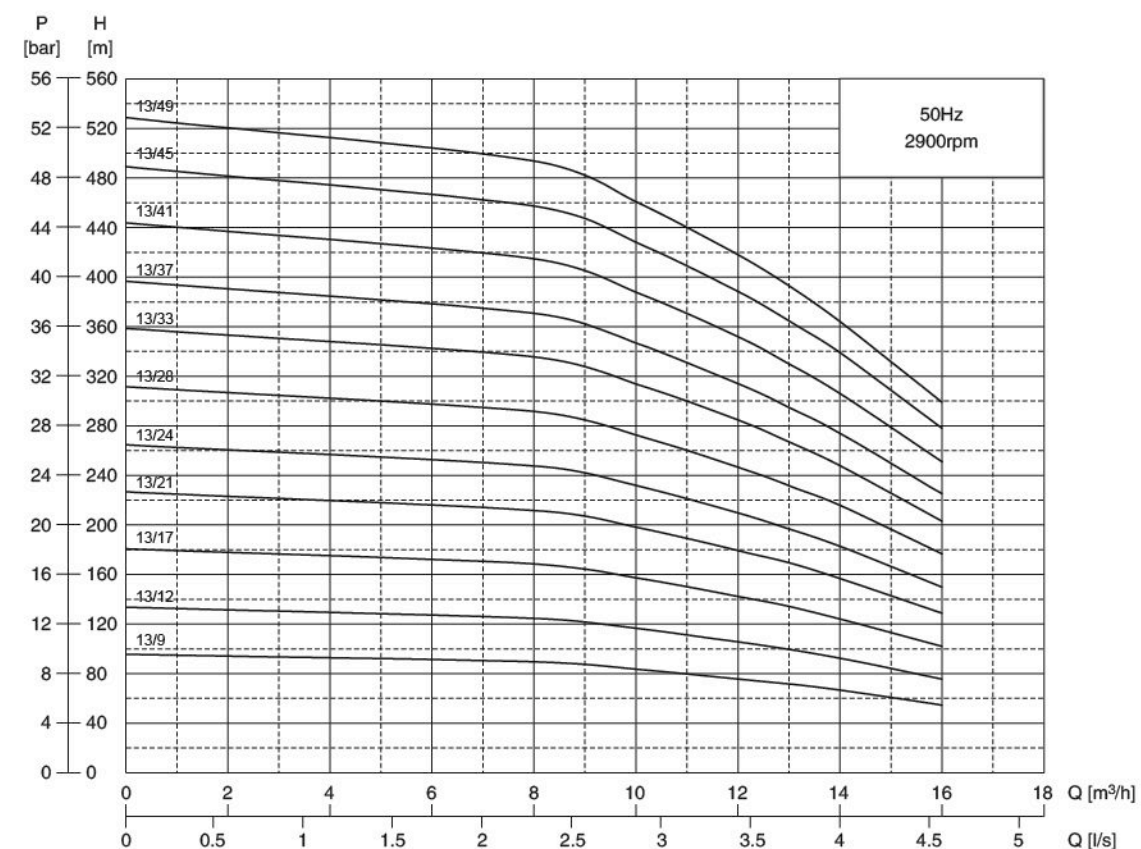

- VS
- VS 1
- VS 2
- VS 3
- VS 5
- VS 8
- VS 13**
- VS 17
- VS 30
- VS 45
- VS 60
- VS 75
- VS 95
- VS 125
- VS 160
- VS 210
- VN
- VN 3
- VN 5
- VN 9
- VL
- VL 3
- VL 5
- VL 9
- OTHERS

STAMPING SS SUBMERSIBLE PUMP

6" VS SERIES / 冲压不锈钢潜水泵 VS系列

TECHNICAL SPECIFICATION 技术参数

MODEL 型号	MOTOR 电机			TOTAL MANOMETRIC HEAD HMT 扬程 [m]	Flow Rate												
	[Kw]	[Hp]	[A]		l/min	0	34	67	100	133	166	200	233	266	300	333	366
				l/sec	0	0.56	1.11	1.67	2.2	2.8	3.3	3.89	4.4	5	5.56	6.11	
				m³/h	0	2	4	6	8	10	12	14	16	18	20	22	
VS 17/6	4	5.5	9.5	68	67	66.5	66	65	63	59	56	50	46	38	31		
VS 17/8	5.5	7.5	12.8	90	90	90	88	86	84	80	74	68	60	51	42		
VS 17/10	5.5	7.5	12.8	112	112	112	110	107	103	98	90	80	70	60	50		
VS 17/13	7.5	10	16.3	145	145	145	143	140	136	130	120	109	95	80	65		
VS 17/15	11	15	24	167	167	167	165	162	158	148	138	128	115	95	73		
VS 17/17	11	15	24	189	188	188	186	182	175	165	153	140	125	108	85		
VS 17/20	11	15	24	222	222	221	220	218	213	198	182	163	145	123	100		
VS 17/22	15	20	32	243	243	243	243	240	235	220	202	184	163	143	115		
VS 17/24	15	20	32	264	264	264	262	258	249	237	220	201	179	157	130		
VS 17/27	15	20	32	301	301	300	298	292	280	268	245	224	200	170	139		
VS 17/30	18.5	25	40	337	337	336	335	328	315	300	280	258	230	198	160		
VS 17/33	18.5	25	40	369	369	368	365	355	342	325	308	280	245	212	166		
VS 17/36	22	30	47	403	403	402	398	392	378	358	338	310	275	235	182		
VS 17/40	22	30	47	443	443	441	439	430	415	395	370	335	298	255	205		

OVERALL DIMENSIONS & WEIGHT 尺寸和重量

MODEL 型号	A [mm]	B [mm]	C [mm]	DN [mm]	H [mm]	M [mm]	Max [mm]	W [kg]	P [kg]	V [m/sec]
VS 17/6	1230	616	614	2"1/2	800	93	131	23	40	0.2
VS 17/8	1421	737	684	2"1/2	800	93	131	27	50	0.2
VS 17/10	1542	858	684	2"1/2	800	93	131	27	56	0.2
VS 17/13	1820	1056	764	2"1/2	800	93	131	31	69	0.2
VS 17/15	1907	1177	730	2"1/2	800	145	142	53	85	0.2
VS 17/17	2028	1298	730	2"1/2	800	145	142	53	90	0.2
VS 17/20	2209	1479	730	2"1/2	800	145	142	53	101	0.2
VS 17/22	2385	1600	785	2"1/2	800	145	142	59	110	0.2
VS 17/24	2506	1721	785	2"1/2	800	145	142	59	116	0.2
VS 17/27	2688	1903	785	2"1/2	800	145	142	59	127	0.2
VS 17/30	2944	2084	860	2"1/2	800	145	142	66	141	0.2
VS 17/33	3126	2266	860	2"1/2	800	145	142	66	149	0.2
VS 17/36	3367	2447	920	2"1/2	800	145	142	73	163	0.2
VS 17/40	3609	2689	920	2"1/2	800	145	142	73	173	0.5

W: Motor weight P: Pump weight(Include motor)
W: 电机重量 P: 水泵总重(含电机)

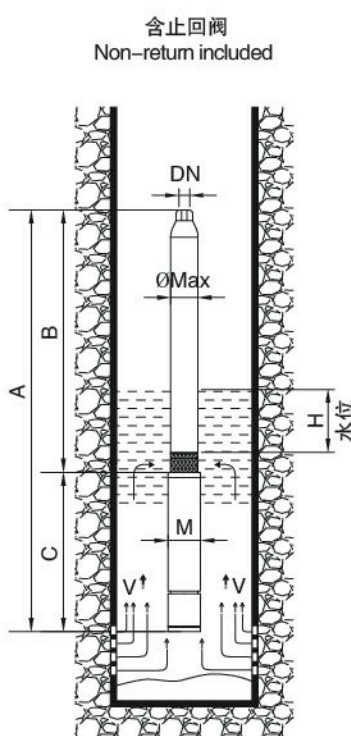

STAMPING SS SUBMERSIBLE PUMP

6" VS SERIES / 冲压不锈钢潜水泵 VS系列

PERFORMANCE CURVE CHART 性能曲线图

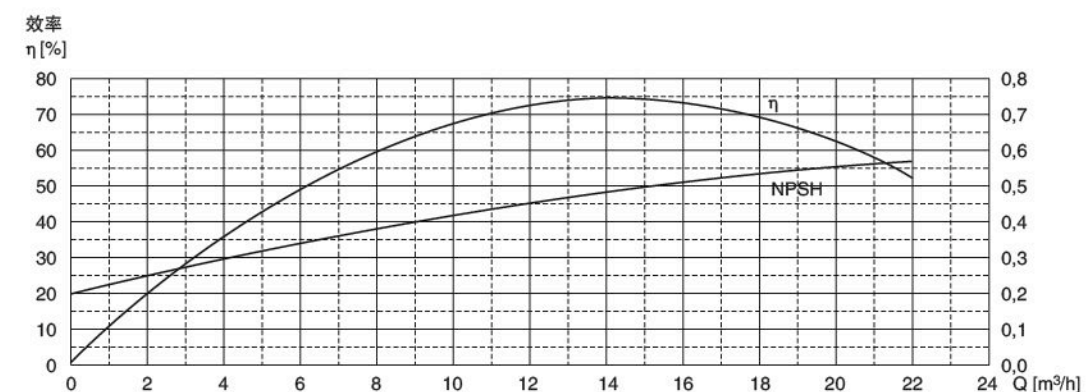
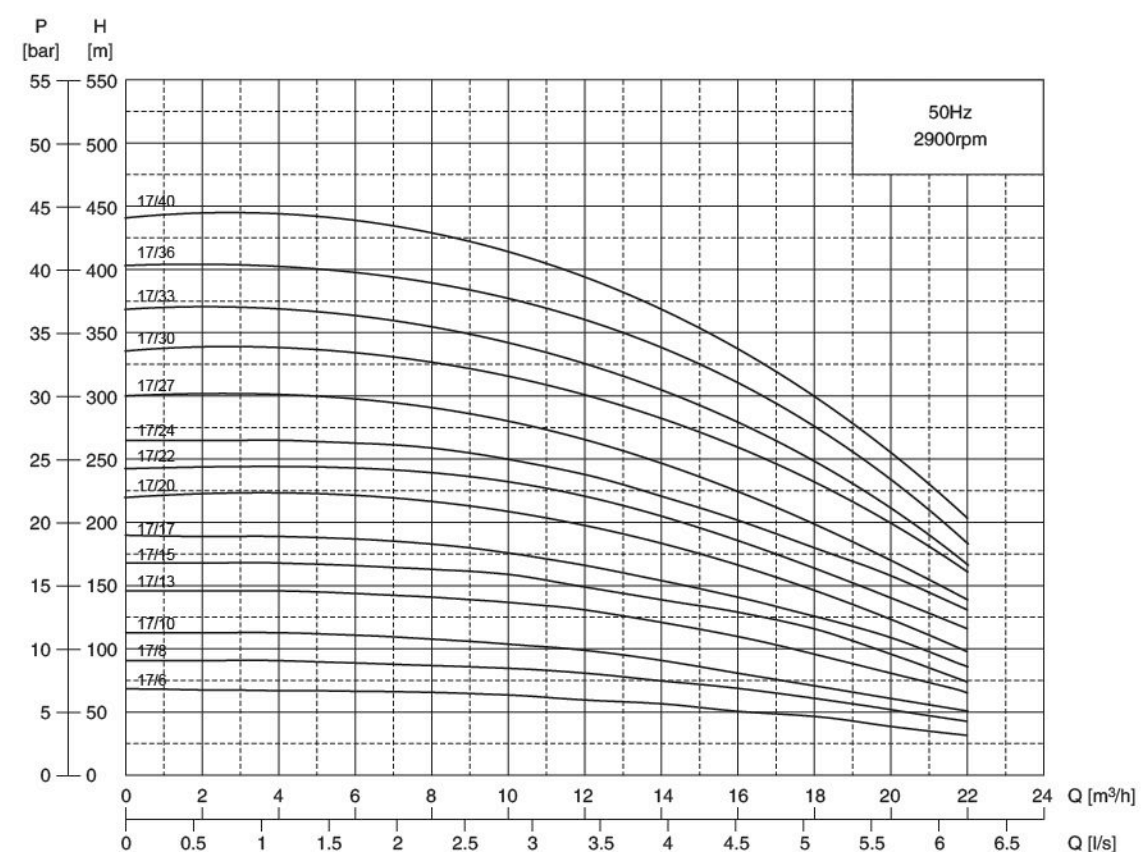

- VS
- VS 1
- VS 2
- VS 3
- VS 5
- VS 8
- VS 13
- VS 17**
- VS 30
- VS 45
- VS 60
- VS 75
- VS 95
- VS 125
- VS 160
- VS 210
- VN
- VN 3
- VN 5
- VN 9
- VL
- VL 3
- VL 5
- VL 9
- OTHERS

STAMPING SS SUBMERSIBLE PUMP

6" VS SERIES / 冲压不锈钢潜水泵 VS系列

TECHNICAL SPECIFICATION 技术参数

MODEL 型号	MOTOR 电机			TOTAL MANOMETRIC HEAD HMT 扬程 [m]							
	[Kw]	[Hp]	[A]	0	120	240	360	480	600	720	
				l/min	0	120	240	360	480	600	720
				l/sec	0	2	4	6	8	10	12
				m³/h	0	7.2	14.4	21.6	28.8	36	43.2
VS 30/4	4	5.5	9.5		47	44	41	37	31	23	11
VS 30/6	5.5	7.5	12.8		70	66	61	55	47	34	16
VS 30/8	7.5	10	16.3		94	87	82	73	63	46	22
VS 30/11	11	15	24		128	120	112	101	86	63	30
VS 30/13	11	15	24		151	142	133	119	102	74	35
VS 30/15	15	20	32		174	164	153	137	118	86	41
VS 30/17	15	20	32		199	186	174	156	133	97	46
VS 30/19	18.5	25	40		225	208	194	174	149	109	52
VS 30/21	18.5	25	40		245	229	215	192	165	120	57
VS 30/24	22	30	47		283	264	245	192	187	139	67
VS 30/28	22	30	47		330	308	286	221	218	162	78
VS 30/31	30	40	64.1		364	341	318	258	240	178	85
VS 30/34	30	40	64.1		388	384	350	317	270	190	94
VS 30/39	37	50	80.1		446	440	405	365	310	220	102
VS 30/46	45	60	96.8		531	526	484	450	382	275	118
VS 30/49	45	60	96.8		565	559	515	470	406	290	132

OVERALL DIMENSIONS & WEIGHT 尺寸和重量

MODEL 型号	A	B	C	DN	H	M	Max	W	P	V
	[mm]	[mm]	[mm]	[mm]	[mm]	[mm]	[mm]	[kg]	[kg]	[m/sec]
VS 30/4	1251	637	614	3"	800	93	131	23	36	0.2
VS 30/6	1513	829	684	3"	800	93	131	27	48	0.2
VS 30/8	1785	1021	764	3"	800	93	131	31	59	0.2
VS 30/11	2055	1325	730	3"	800	145	142	53	81	0.2
VS 30/13	2247	1517	730	3"	800	145	142	53	90	0.2
VS 30/15	2494	1709	785	3"	800	145	142	59	100	0.2
VS 30/17	2686	1901	785	3"	800	145	142	59	110	0.2
VS 30/19	2953	2093	860	3"	800	145	142	66	122	0.5
VS 30/21	3145	2285	860	3"	800	145	142	66	129	0.5
VS 30/24	3393	2573	920	3"	800	145	142	73	145	0.5
VS 30/28	3877	2957	920	3"	800	145	142	73	164	0.5
VS 30/31	4295	3245	1050	3"	800	145	142	85	181	0.5
VS 30/34	4583	3533	1050	3"	800	145	142	85	191	0.5
VS 30/39	5440	4260	1180	3"	800	145	142	98	271	0.5
VS 30/46	6151	4881	1270	3"	800	192	188	177	310	0.5
VS 30/49	6439	5169	1270	3"	800	192	188	177	320	0.5

W: Motor weight P: Pump weight(Include motor)
W: 电机重量 P: 水泵总重(含电机)

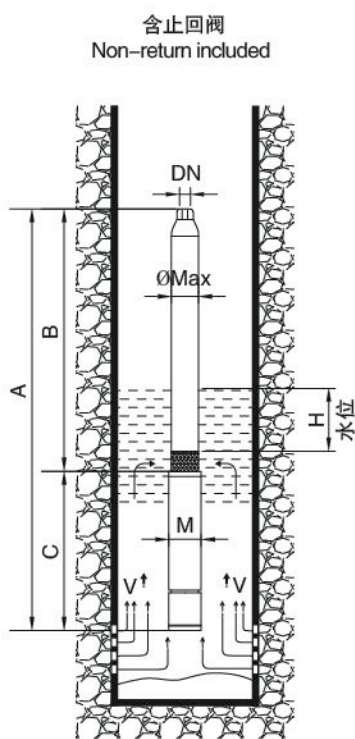

STAMPING SS SUBMERSIBLE PUMP

6" VS SERIES / 冲压不锈钢潜水泵 VS系列

PERFORMANCE CURVE CHART 性能曲线图

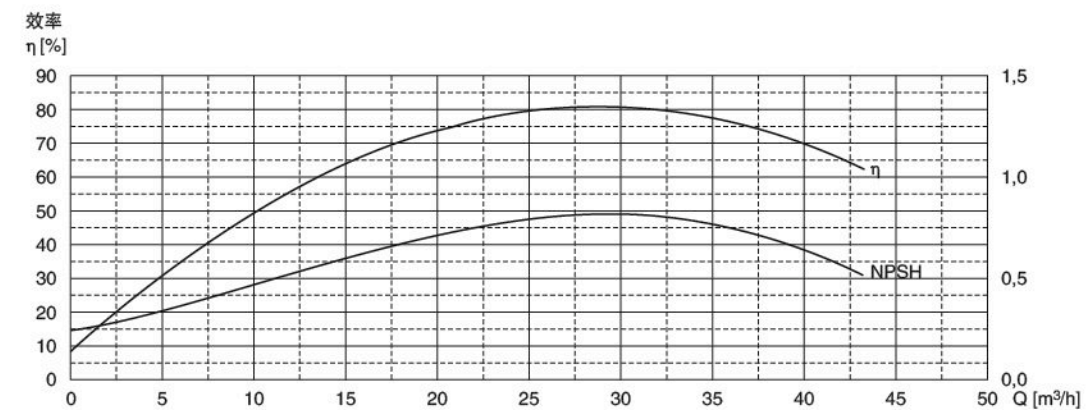
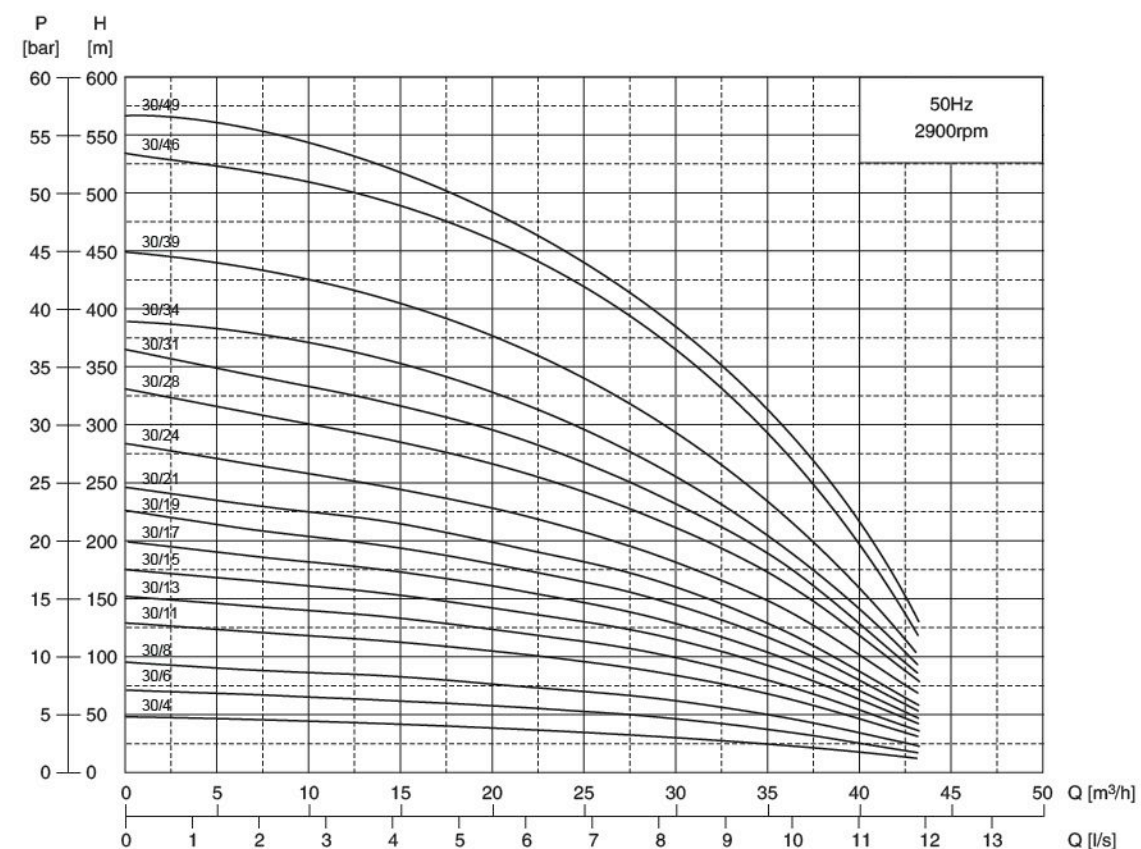

- VS
- VS 1
- VS 2
- VS 3
- VS 5
- VS 8
- VS 13
- VS 17
- VS 30**
- VS 45
- VS 60
- VS 75
- VS 95
- VS 125
- VS 160
- VS 210
- VN
- VN 3
- VN 5
- VN 9
- VL
- VL 3
- VL 5
- VL 9
- OTHERS

STAMPING SS SUBMERSIBLE PUMP

6" VS SERIES / 冲压不锈钢潜水泵 VS系列

TECHNICAL SPECIFICATION 技术参数

MODEL 型号	MOTOR 电机			TOTAL MANOMETRIC HEAD HMT 扬程 [m]	0	360	480	600	720	840	960	
	[Kw]	[Hp]	[A]		0	6	8	10	12	14	16	
					l/min	l/sec	m ³ /h	0	21.6	28.8	36	43.2
VS 45/3	5.5	7.5	12.8	47	38	34	31	29	26	21		
VS 45/5	7.5	10	16.3	78	63	57	52	48	41	36		
VS 45/6	11	15	24	94	75	69	63	57	51	43		
VS 45/7	11	15	24	109	88	80	73	67	59	50		
VS 45/8	15	20	32	117	101	92	83	76	68	57		
VS 45/9	15	20	32	140	113	103	94	86	76	64		
VS 45/11	18.5	25	40	156	138	126	115	105	93	78		
VS 45/14	22	30	47	203	176	161	145	134	119	100		
VS 45/16	30	40	66.4	250	201	183	167	153	136	114		
VS 45/18	30	40	66.4	265	226	206	188	172	153	128		
VS 45/21	37	50	82	328	264	241	219	200	179	150		
VS 45/23	37	50	82	359	289	264	240	220	195	164		
VS 45/26	45	60	96.8	406	327	298	271	248	221	186		

OVERALL DIMENSIONS & WEIGHT 尺寸和重量

MODEL 型号	A [mm]	B [mm]	C [mm]	DN [mm]	H [mm]	M [mm]	Max [mm]	W [kg]	P [kg]	V [m/sec]
VS 45/3	1274	590	684	4"	800	93	144	27	42	0.2
VS 45/5	1596	832	764	4"	800	93	144	31	62	0.2
VS 45/6	1675	945	730	4"	800	145	144	53	73	0.2
VS 45/7	1788	1058	730	4"	800	145	144	53	79	0.2
VS 45/8	1956	1171	785	4"	800	145	144	59	88	0.2
VS 45/9	2069	1284	785	4"	800	145	144	59	96	0.2
VS 45/11	2370	1510	860	4"	800	145	144	66	111	0.5
VS 45/14	2769	1849	920	4"	800	145	144	73	131	0.5
VS 45/16	3125	2075	1050	4"	800	145	144	85	145	0.5
VS 45/18	3351	2301	1050	4"	800	145	144	85	194	0.5
VS 45/21	3900	2720	1180	4"	800	145	144	98	239	0.5
VS 45/23	4126	2946	1180	4"	800	145	144	98	248	0.5
VS 45/26	4673	3403	1270	4"	800	192	188	177	278	0.5

W: Motor weight P: Pump weight(Include motor)
W: 电机重量 P: 水泵总重(含电机)

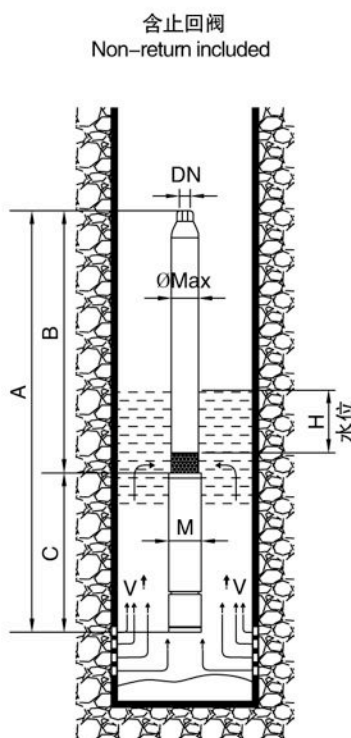

STAMPING SS SUBMERSIBLE PUMP

6" VS SERIES / 冲压不锈钢潜水泵 VS系列

PERFORMANCE CURVE CHART 性能曲线图

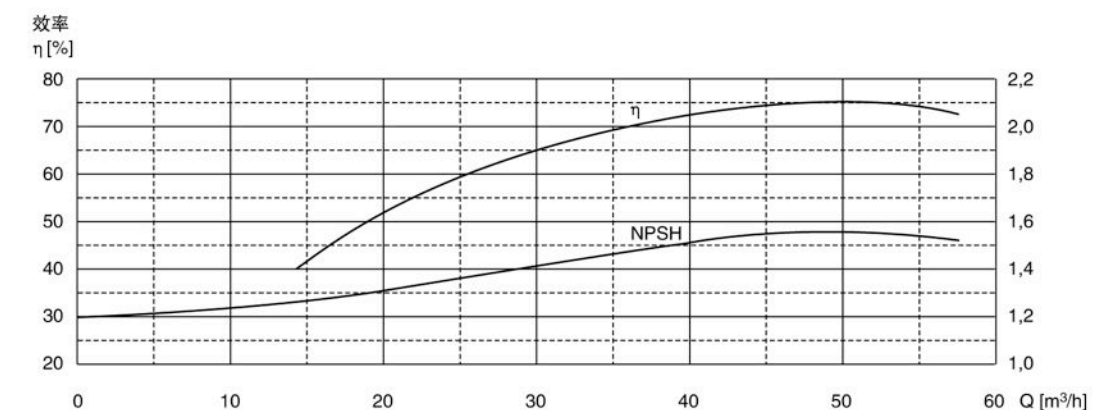
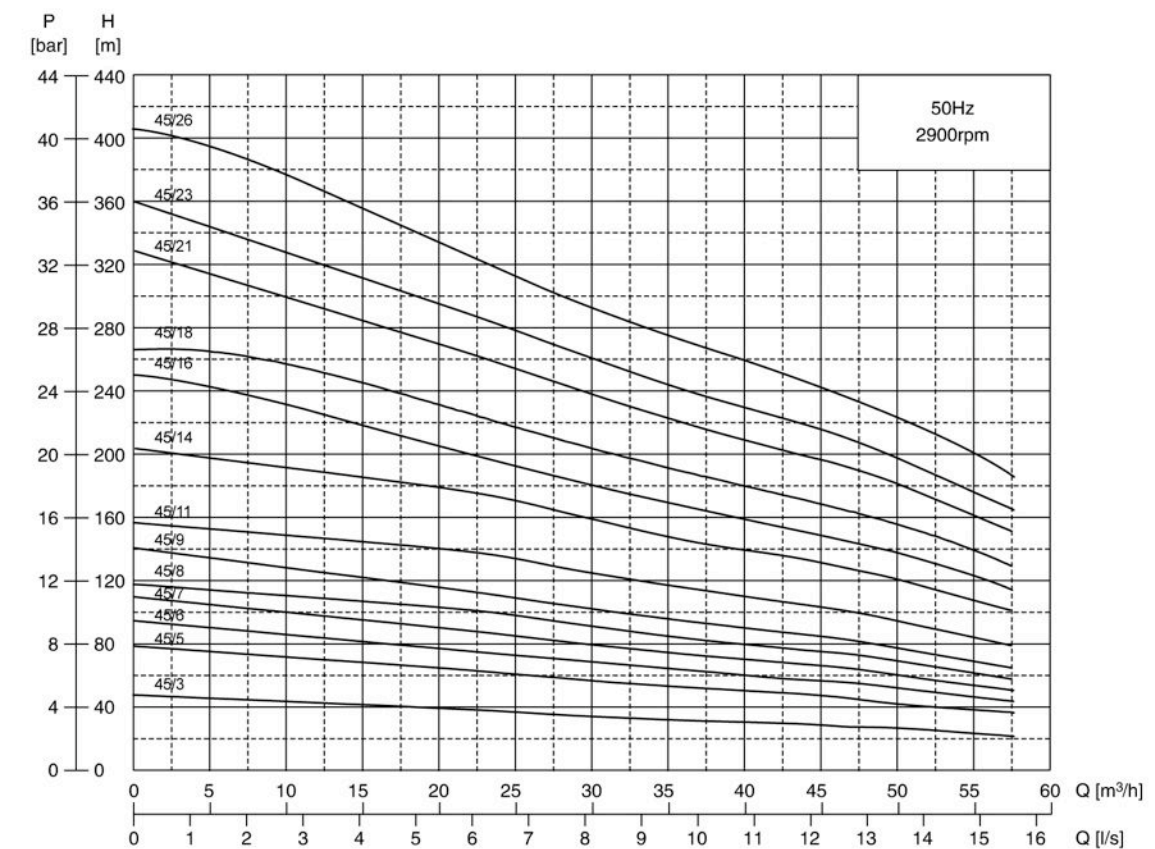

- VS
- VS 1
- VS 2
- VS 3
- VS 5
- VS 8
- VS 13
- VS 17
- VS 30
- VS 45**
- VS 60
- VS 75
- VS 95
- VS 125
- VS 160
- VS 210
- VN
- VN 3
- VN 5
- VN 9
- VL
- VL 3
- VL 5
- VL 9
- OTHERS

STAMPING SS SUBMERSIBLE PUMP

6" VS SERIES / 冲压不锈钢潜水泵 VS系列

TECHNICAL SPECIFICATION 技术参数

MODEL 型号	MOTOR 电机			TOTAL MANOMETRIC HEAD HMT 扬程 [m]	0	720	960	1020	1080	1140	1200	
	[Kw]	[Hp]	[A]		l/min	l/sec	m ³ /h	0	12	16	17	18
VS 60/2	4	5.5	10.2	29	19	16	15	13	12	11		
VS 60/3	5.5	7.5	13.6	44	29	24	22	20	17	15		
VS 60/4	7.5	10	17.2	58	38	32	29	26	23	20		
VS 60/5	11	15	24	73	48	40	37	33	29	26		
VS 60/6	11	15	24	88	58	48	45	39	35	34		
VS 60/7	15	20	33.1	103	67	56	52	46	41	38		
VS 60/8	15	20	33.1	117	77	64	60	52	47	44		
VS 60/10	18.5	25	41.8	146	96	80	75	66	58	50		
VS 60/12	22	30	47	175	115	96	90	79	70	62		
VS 60/14	30	40	66.4	205	135	112	105	92	81	75		
VS 60/17	30	40	66.4	248	164	135	128	113	99	90		
VS 60/19	37	50	82	274	185	151	138	124	110	99		
VS 60/21	37	50	82	307	202	167	156	138	123	110		
VS 60/24	45	60	96.8	346	233	191	175	157	139	126		

OVERALL DIMENSIONS & WEIGHT 尺寸和重量

MODEL 型号	A [mm]	B [mm]	C [mm]	DN [mm]	H [mm]	M [mm]	Max [mm]	W [kg]	P [kg]	V [m/sec]
VS 60/2	1091	477	614	4"	800	93	144	23	39	0.2
VS 60/3	1274	590	684	4"	800	93	144	27	42	0.2
VS 60/4	1467	703	764	4"	800	93	144	31	50	0.2
VS 60/5	1562	832	730	4"	800	145	144	53	68	0.2
VS 60/6	1675	945	730	4"	800	145	144	53	73	0.2
VS 60/7	1843	1058	785	4"	800	145	144	59	84	0.2
VS 60/8	1956	1171	785	4"	800	145	144	59	89	0.2
VS 60/10	2257	1397	860	4"	800	145	144	66	100	0.5
VS 60/12	2543	1623	920	4"	800	145	144	73	114	0.5
VS 60/14	2899	1849	1050	4"	800	145	144	85	137	0.5
VS 60/17	3238	2188	1050	4"	800	145	144	85	107	0.5
VS 60/19	3674	2494	1180	4"	800	145	144	98	201	0.5
VS 60/21	3902	2722	1180	4"	800	145	144	98	220	0.5
VS 60/24	4447	3177	1270	800	192	188	177	260	0.5	

W: Motor weight P: Pump weight(Include motor)
W: 电机重量 P: 水泵总重(含电机)

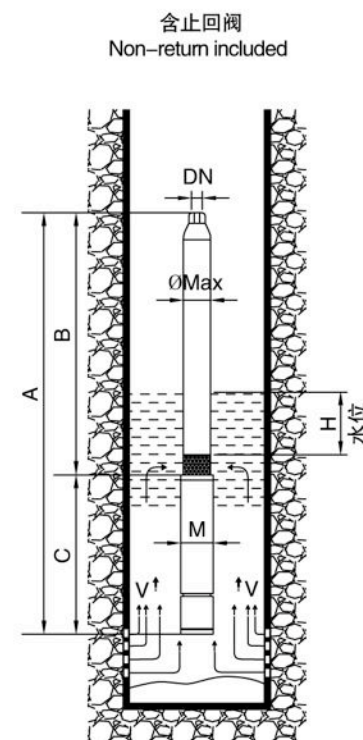

STAMPING SS SUBMERSIBLE PUMP

6" VS SERIES / 冲压不锈钢潜水泵 VS系列

PERFORMANCE CURVE CHART 性能曲线图

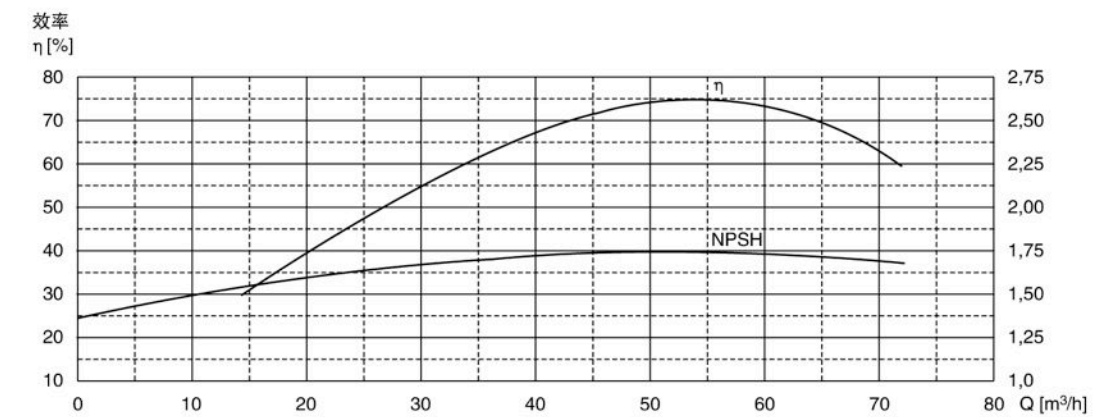
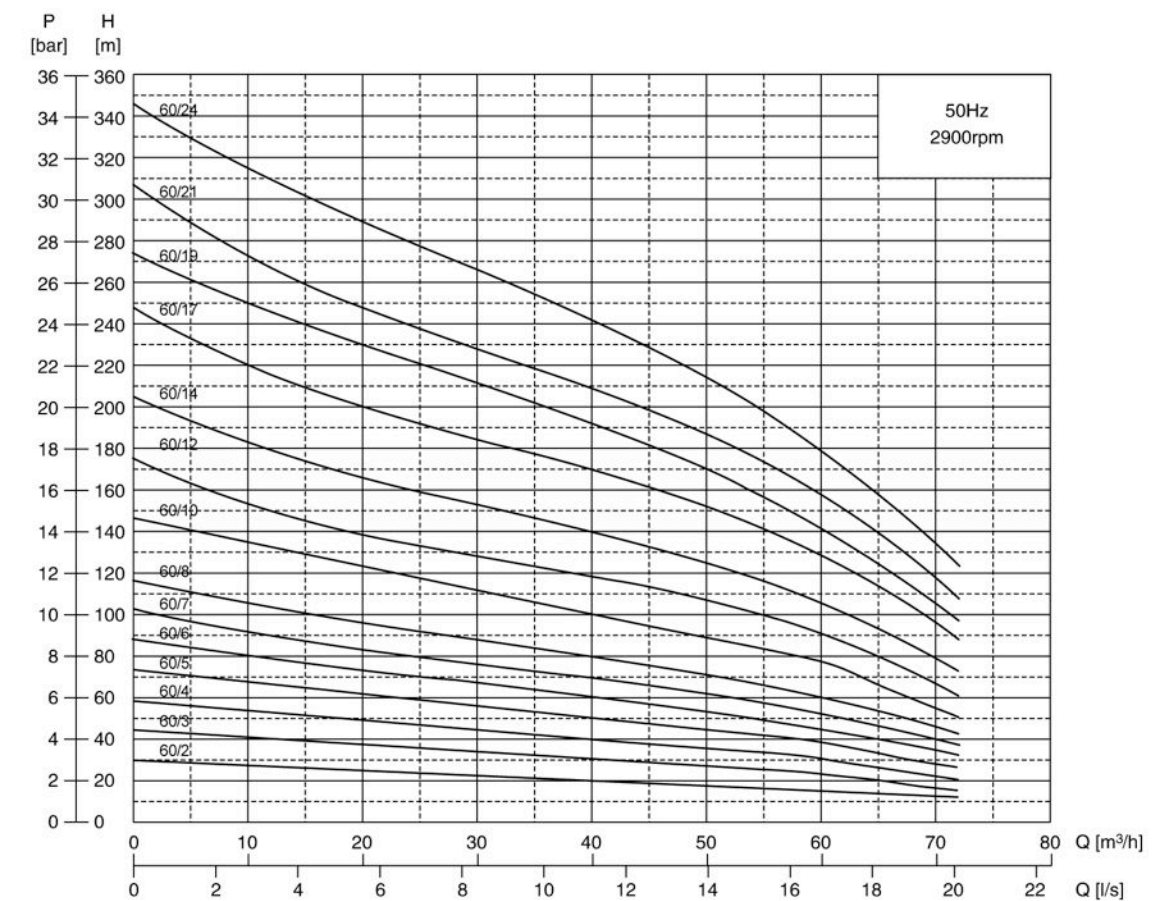

- VS
- VS 1
- VS 2
- VS 3
- VS 5
- VS 8
- VS 13
- VS 17
- VS 30
- VS 45
- VS 60**
- VS 75
- VS 95
- VS 125
- VS 160
- VS 210
- VN
- VN 3
- VN 5
- VN 9
- VL
- VL 3
- VL 5
- VL 9
- OTHERS

STAMPING SS SUBMERSIBLE PUMP

8" VS SERIES / 冲压不锈钢潜水泵 VS系列

TECHNICAL SPECIFICATION 技术参数

MODEL 型号	MOTOR 电机			l/min l/sec m³/h	0	960	1080	1200	1320	1440	1560
	[Kw]	[Hp]	[A]		0	16	18	20	22	24	26
VS 75/1	5.5	7.5	13.6	22	16	15	14	13	12	10	
VS 75/2	7.5	10	16.3	43	32	30	28	26	24	20	
VS 75/3	11	15	24	65	47	45	43	40	35	30	
VS 75/4	15	20	32	86	63	61	57	53	47	40	
VS 75/5	18.5	25	40	108	79	76	71	66	59	50	
VS 75/6	22	30	49.1	129	95	91	85	79	71	60	
VS 75/7	30	40	66.4	151	111	106	100	93	83	70	
VS 75/8	30	40	66.4	172	127	121	114	106	94	80	
VS 75/9	37	50	82	194	142	136	128	119	106	90	
VS 75/10	45	60	93	215	158	151	142	132	118	100	
VS 75/11	45	60	93	237	174	167	156	145	130	110	
VS 75/12	45	60	93	258	190	182	171	159	141	120	
VS 75/13	55	75	114	280	206	197	185	172	153	130	
VS 75/14	55	75	114	302	222	212	199	185	165	140	
VS 75/15	55	75	122	323	237	227	213	198	177	150	
VS 75/17	75	100	154	366	269	257	242	225	200	170	
VS 75/18	75	100	154	390	285	273	256	238	212	180	
VS 75/20	75	100	154	431	316	303	284	264	236	200	
VS 75/21	93	125	188	452	332	318	299	278	248	210	
VS 75/22	93	125	188	474	348	333	313	291	259	220	
VS 75/23	93	125	188	495	364	348	327	304	271	230	
VS 75/24	93	125	188	517	380	363	341	317	283	240	
VS 75/25	93	125	188	538	396	379	355	330	295	250	
VS 75/26	110	150	235	560	411	394	370	344	306	260	
VS 75/27	110	150	235	581	427	409	384	357	318	270	
VS 75/28	110	150	235	603	443	424	398	370	330	280	

OVERALL DIMENSIONS & WEIGHT 尺寸和重量

MODEL 型号	A [mm]	B [mm]	C [mm]	DN [mm]	H [mm]	M [mm]	Max [mm]	W [kg]	P [kg]	V [m³/sec]
VS 75/1	1249	618	631	5"	300	145	172	44	58	0.5
VS 75/2	1406	746	660	5"	300	145	172	46	66	0.5
VS 75/3	1604	874	730	5"	300	145	172	53	79	0.5
VS 75/4	1788	1003	785	5"	300	145	172	59	91	0.5
VS 75/5	1991	1131	860	5"	300	145	172	66	104	0.5
VS 75/6	2179	1259	920	5"	300	145	172	73	127	0.5
VS 75/7	2437	1387	1050	5"	300	145	172	85	139	0.5
VS 75/8	2565	1515	1050	5"	300	145	172	85	148	0.5
VS 75/9	2823	1643	1180	5"	300	145	172	98	160	0.5
VS 75/10	3041	1771	1270	5"	300	192	200	177	245	0.5
VS 75/11	3184	1914	1270	5"	300	192	200	177	251	0.5
VS 75/12	3313	2043	1270	5"	300	192	200	177	257	0.5
VS 75/13	3522	2172	1350	5"	300	192	200	192	278	0.5
VS 75/14	3650	2300	1350	5"	300	192	200	192	284	0.5
VS 75/15	3779	2429	1350	5"	300	192	200	192	290	0.5
VS 75/17	4275	2685	1590	5"	300	192	200	237	347	0.5
VS 75/18	4404	2814	1590	5"	300	192	200	237	353	0.5
VS 75/20	4954	3364	1590	5"	300	192	200	237	365	0.5
VS 75/21	5322	3492	1830	5"	300	192	200	283	417	0.5
VS 75/22	5510	3680	1830	5"	300	192	200	283	423	0.5
VS 75/23	5638	3808	1830	5"	300	192	200	283	429	0.5
VS 75/24	5766	3936	1830	5"	300	192	200	283	435	0.5
VS 75/25	5894	4064	1830	5"	300	192	200	283	441	0.5
VS 75/26	6252	4192	2060	5"	300	192	200	333	497	0.5
VS 75/27	6380	4320	2060	5"	300	192	200	333	503	0.5
VS 75/28	6856	4448	2408	5"	300	192	200	333	509	0.5

W: Motor weight P: Pump weight(Include motor)
W: 电机重量 P: 水泵总重(含电机)

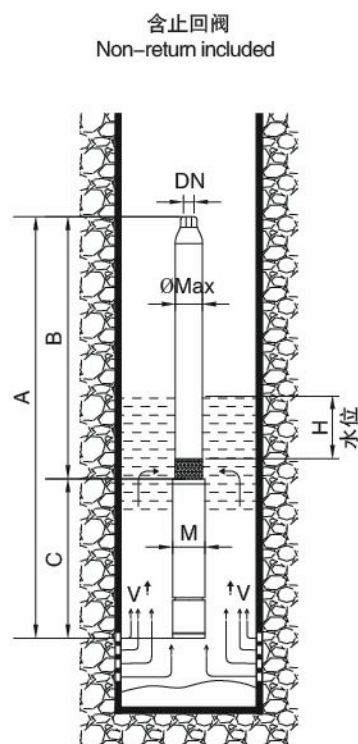

STAMPING SS SUBMERSIBLE PUMP

8" VS SERIES / 冲压不锈钢潜水泵 VS系列

PERFORMANCE CURVE CHART 性能曲线图

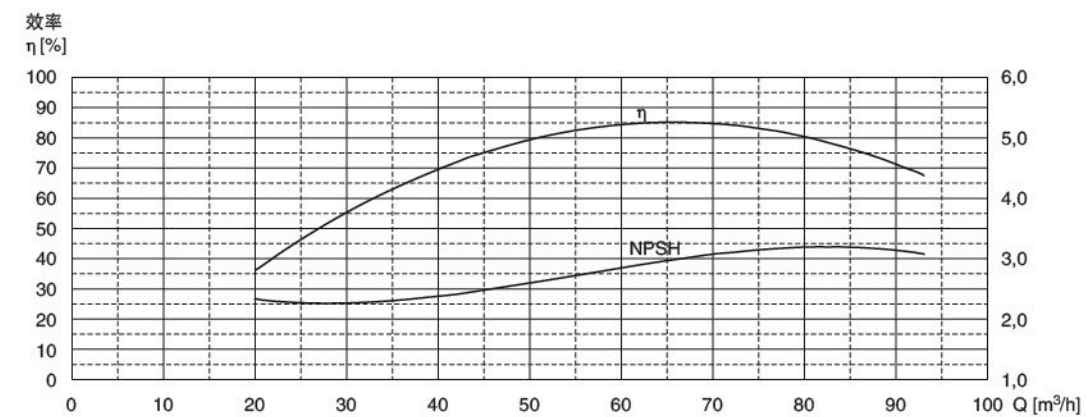
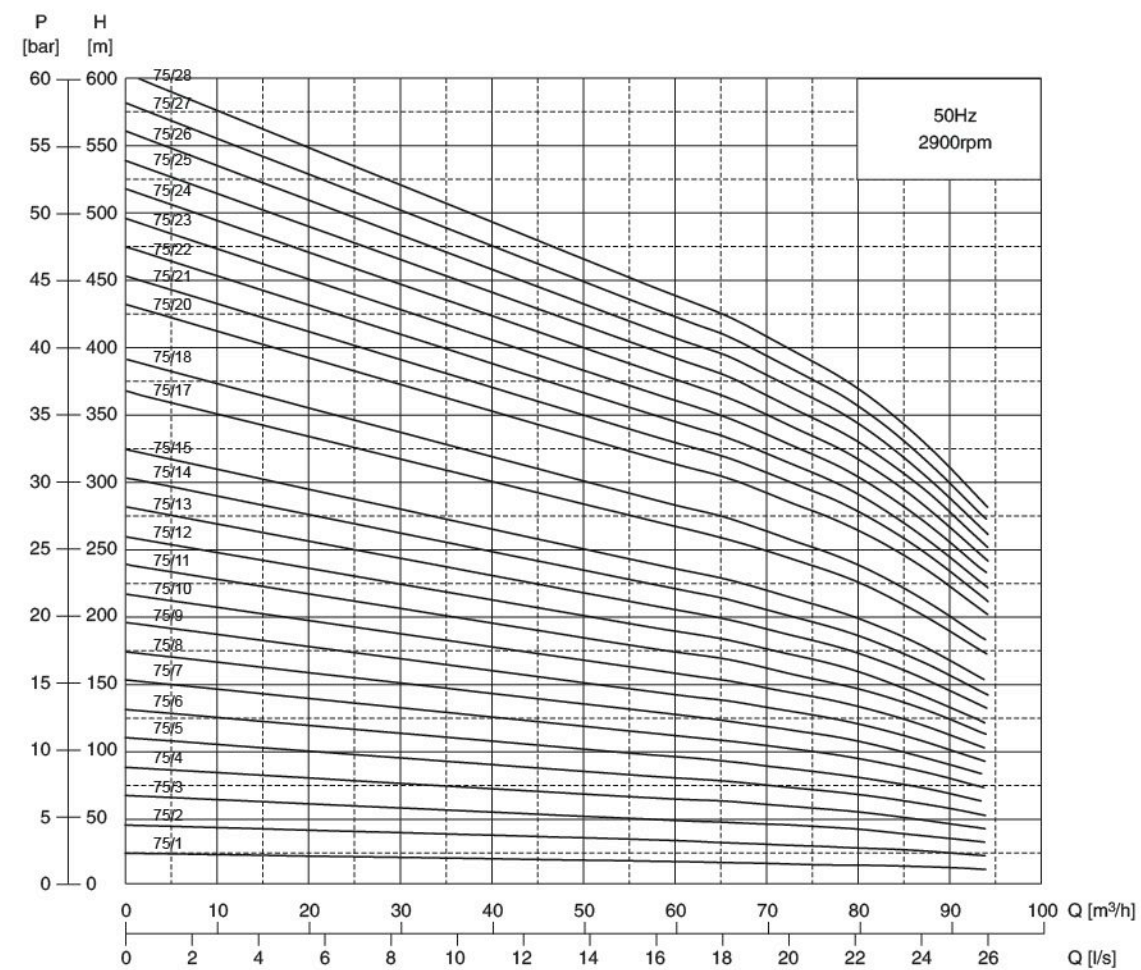

- VS
- VS 1
- VS 2
- VS 3
- VS 5
- VS 8
- VS 13
- VS 17
- VS 30
- VS 45
- VS 60
- VS 75
- VS 95
- VS 125
- VS 160
- VS 210
- VN
- VN 3
- VN 5
- VN 9
- VL
- VL 3
- VL 5
- VL 9
- OTHERS

STAMPING SS SUBMERSIBLE PUMP

8" VS SERIES / 冲压不锈钢潜水泵 VS系列

TECHNICAL SPECIFICATION 技术参数

MODEL 型号	MOTOR 电机			l/min l/sec m³/h	0	1200	1320	1440	1560	1680	1800
	[Kw]	[Hp]	[A]		0	20	22	24	22	26	28
VS 95/1	5.5	7.5	12.8	19	15	14	13	13	12	10	9
VS 95/2	11	15	24	38	29	28	26	26	24	20	17
VS 95/3	15	20	32	57	44	42	39	40	36	30	26
VS 95/4	18.5	25	40	77	59	57	53	53	48	40	34
VS 95/5	22	30	47	96	73	71	66	66	60	50	43
VS 95/6	30	40	66.4	115	88	85	79	79	71	60	52
VS 95/7	30	40	66.4	134	103	99	92	93	83	70	60
VS 95/8	37	50	82.2	153	118	113	105	106	95	80	69
VS 95/9	37	50	82.2	172	132	127	118	119	107	90	77
VS 95/10	45	60	93	192	147	141	131	132	119	100	86
VS 95/11	55	75	107	211	162	155	145	145	131	110	94
VS 95/12	55	75	107	230	176	170	158	159	143	120	103
VS 95/13	55	75	107	249	191	184	171	172	155	131	112
VS 95/14	55	75	107	268	206	198	184	185	167	141	120
VS 95/15	75	100	154	287	220	212	197	198	179	151	129
VS 95/16	75	100	154	306	235	226	210	225	190	161	137
VS 95/17	75	100	154	326	250	240	223	238	202	171	146
VS 95/18	93	125	188	345	265	254	237	364	214	181	155
VS 95/19	93	125	188	364	279	268	250	278	226	191	163
VS 95/20	93	125	188	383	294	283	263	291	238	201	172
VS 95/21	93	125	188	402	309	297	276	304	250	211	180
VS 95/22	110	150	235	421	323	311	289	317	262	221	189

OVERALL DIMENSIONS & WEIGHT 尺寸和重量

MODEL 型号	A [mm]	B [mm]	C [mm]	DN [mm]	H [mm]	M [mm]	Max [mm]	W [kg]	P [kg]	V [m³/sec]
VS 95/1	1249	618	631	5"	300	145	172	44	69	0.5
VS 95/2	1476	746	730	5"	300	145	172	53	82	0.5
VS 95/3	1659	874	785	5"	300	145	172	59	92	0.5
VS 95/4	1863	1003	860	5"	300	145	172	66	103	0.5
VS 95/5	2051	1131	920	5"	300	145	172	73	113	0.5
VS 95/6	2309	1259	1050	5"	300	145	172	85	128	0.5
VS 95/7	2437	1387	1050	5"	300	145	172	85	132	0.5
VS 95/8	2695	1515	1180	5"	300	145	172	98	149	0.5
VS 95/9	2822	1642	1180	5"	300	145	172	98	152	0.5
VS 95/10	3055	1785	1270	5"	300	192	200	177	236	0.5
VS 95/11	3264	1914	1350	5"	300	192	200	192	242	0.5
VS 95/12	3393	2043	1350	5"	300	192	200	192	258	0.5
VS 95/13	3522	2172	1350	5"	300	192	200	192	262	0.5
VS 95/14	3650	2300	1350	5"	300	192	200	192	266	0.5
VS 95/15	4019	2429	1590	5"	300	192	200	237	270	0.5
VS 95/16	4147	2557	1590	5"	300	192	200	237	274	0.5
VS 95/17	4275	2685	1590	5"	300	192	200	237	278	0.5
VS 95/18	4938	3108	1830	5"	300	192	200	283	328	0.5
VS 95/19	5066	3236	1830	5"	300	192	200	283	332	0.5
VS 95/20	5194	3364	1830	5"	300	192	200	283	336	0.5
VS 95/21	5322	3492	1830	5"	300	192	200	283	340	0.5
VS 95/22	5680	3620	2060	5"	300	192	200	283	394	0.5

W: Motor weight P: Pump weight(Include motor)
W: 电机重量 P: 水泵总重(含电机)

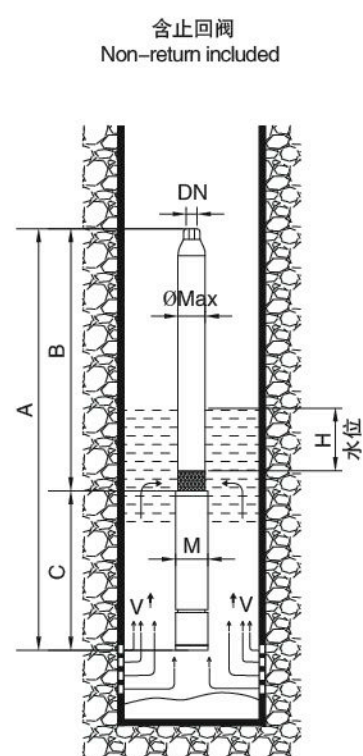

STAMPING SS SUBMERSIBLE PUMP

8" VS SERIES / 冲压不锈钢潜水泵 VS系列

PERFORMANCE CURVE CHART 性能曲线图

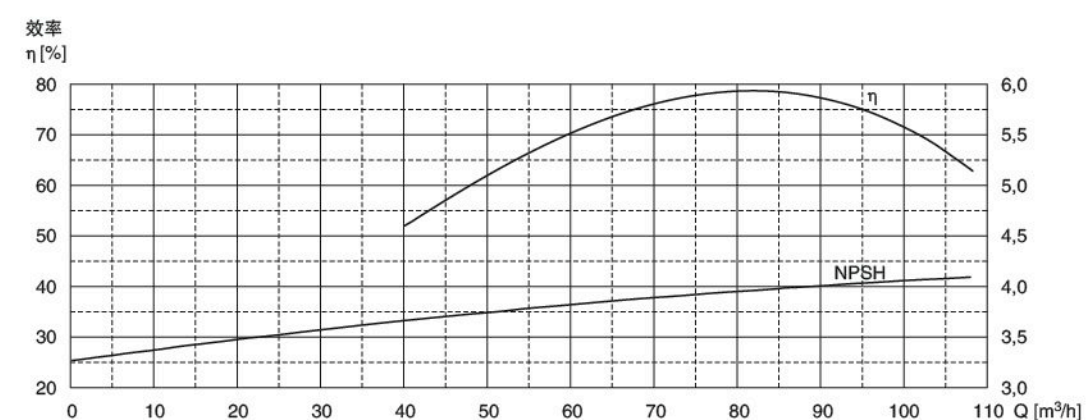
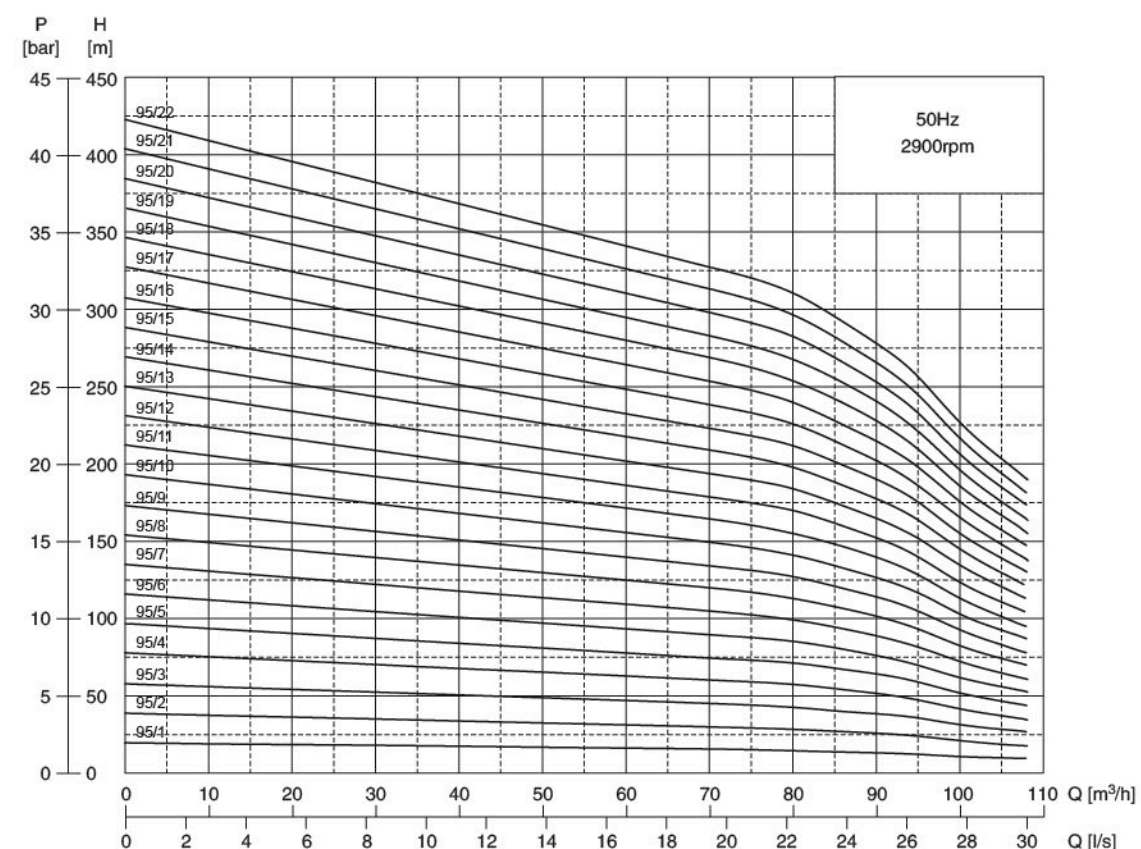

- VS
- VS 1
- VS 2
- VS 3
- VS 5
- VS 8
- VS 13
- VS 17
- VS 30
- VS 45
- VS 60
- VS 75
- VS 95
- VS 125
- VS 160
- VS 210
- VN
- VN 3
- VN 5
- VN 9
- VL
- VL 3
- VL 5
- VL 9
- OTHERS

STAMPING SS SUBMERSIBLE PUMP

10" VS SERIES / 冲压不锈钢潜水泵 VS系列

TECHNICAL SPECIFICATION 技术参数

MODEL 型号	MOTOR 电机			l/min	0	667	1000	1333	1667	2000	2333	2667
	[Kw]	[Hp]	[A]		l/sec	0	11.1	16.67	22.22	27.78	33.33	38.89
				m³/h	0	40	60	80	100	120	140	160
VS 125/1	11	15	20.5		32	31	28	26	24	22	18	14
VS 125/2	22	30	48.5		64	62	56	52	49	44	37	28
VS 125/3	30	40	61.7		96	94	84	78	73	66	55	42
VS 125/4	37	50	82.2		128	125	112	104	97	87	73	56
VS 125/5	55	75	107		160	158	139	131	121	109	92	70
VS 125/6	75	100	150.7	TOTAL MANOM ETRIC HEAD HMT 扬程 [m]	192	187	167	157	146	131	110	84
VS 125/7	75	100	150.7		224	218	195	183	170	153	129	98
VS 125/8	75	100	150.7		257	250	223	209	194	175	147	112
VS 125/9	93	125	184.8		289	281	251	235	218	197	165	126
VS 125/10	93	125	184.8		321	312	279	261	243	219	184	140
VS 125/11	110	150	215.9		353	343	307	287	267	240	202	154
VS 125/12	132	175	247.6		358	374	335	313	291	262	220	168
VS 125/13	132	175	247.6		417	405	363	339	316	284	239	182
VS 125/14	147	200	282.1		449	437	391	366	340	306	257	197
VS 125/15	147	200	282.1		481	468	418	392	364	328	275	211

OVERALL DIMENSIONS & WEIGHT 尺寸和重量

MODEL 型号	A	B	C	DN	H	M	Max	W	P	V
	[mm]	[mm]	[mm]	[mm]	[mm]	[mm]	[mm]	[kg]	[kg]	[m/sec]
VS 125/1	1381	651	730	6"	1200	145	218	53	79	0.5
VS 125/2	1727	807	920	6"	1200	145	218	73	103	0.5
VS 125/3	2013	963	1050	6"	1200	145	218	85	123	0.5
VS 125/4	2299	1119	1180	6"	1200	145	218	98	176	0.5
VS 125/5	2625	1275	1350	6"	1200	192	227	192	251	0.5
VS 125/6	3021	1431	1590	6"	1200	192	227	237	289	0.5
VS 125/7	3177	1587	1590	6"	1200	192	227	237	308	0.5
VS 125/8	3333	1743	1590	6"	1200	192	227	237	314	0.5
VS 125/9	3729	1899	1830	6"	1200	192	227	283	366	0.5
VS 125/10	3885	2055	1830	6"	1200	192	227	283	372	0.5
VS 125/11	4567	2507	2060	6"	1200	192	227	333	438	0.5
VS 125/12	4584	2714	1870	6"	1200	232	237	435	556	0.5
VS 125/13	4740	2870	1870	6"	1200	232	237	435	562	0.5
VS 125/14	5095	3025	2070	6"	1200	232	237	500	633	0.5
VS 125/15	5251	3181	2070	6"	1200	232	237	500	639	0.5

W: Motor weight P: Pump weight(Include motor)
W: 电机重量 P: 水泵总重(含电机)

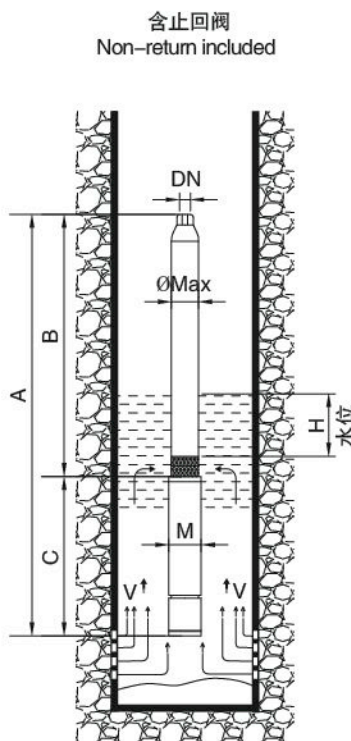

STAMPING SS SUBMERSIBLE PUMP

10" VS SERIES / 冲压不锈钢潜水泵 VS系列

PERFORMANCE CURVE CHART 性能曲线图

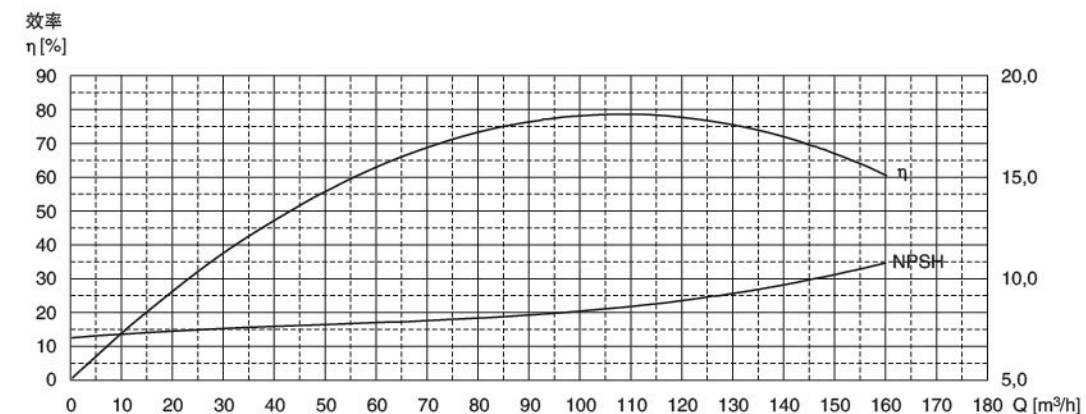
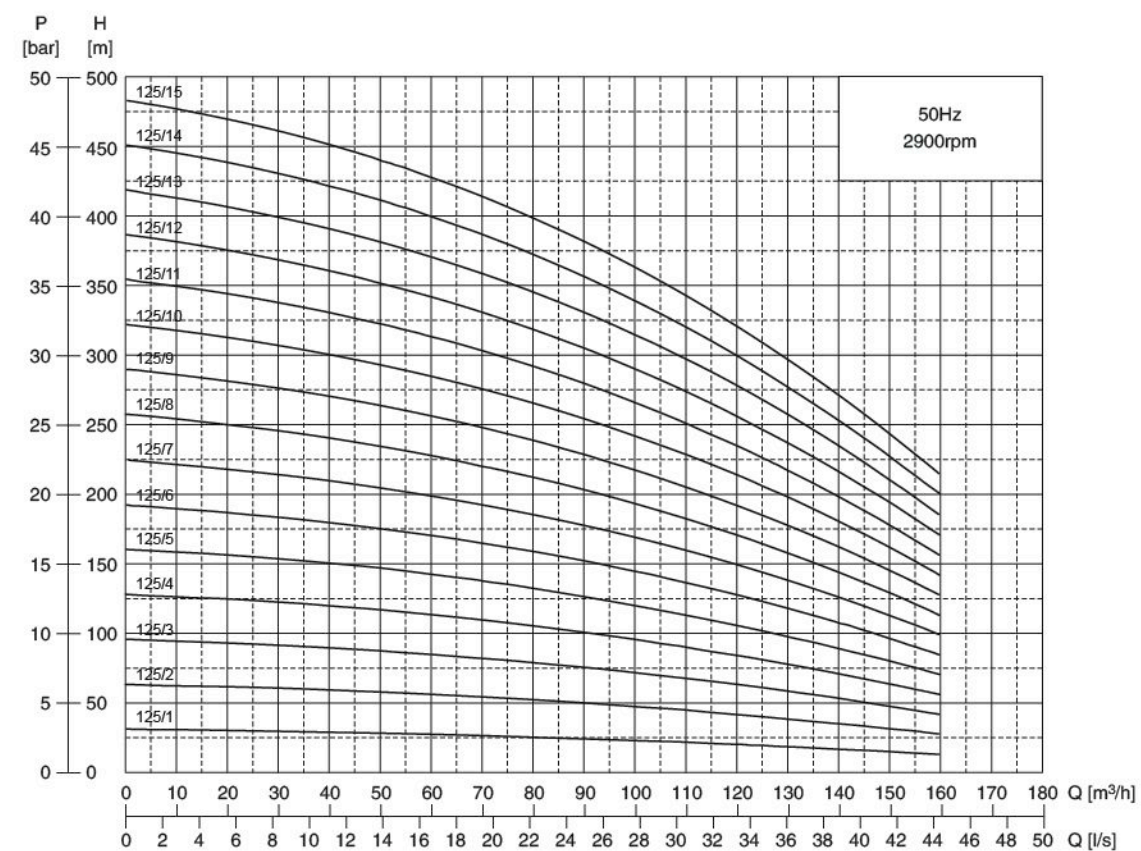

- VS
- VS 1
- VS 2
- VS 3
- VS 5
- VS 8
- VS 13
- VS 17
- VS 30
- VS 45
- VS 60
- VS 75
- VS 95
- VS 125
- VS 160
- VS 210
- VN
- VN 3
- VN 5
- VN 9
- VL
- VL 3
- VL 5
- VL 9
- OTHERS

STAMPING SS SUBMERSIBLE PUMP

10" VS SERIES / 冲压不锈钢潜水泵 VS系列

TECHNICAL SPECIFICATION 技术参数

MODEL 型号	MOTOR 电机			TOTAL MANOMETRIC HEAD HMT 扬程 [m]												
	[Kw]	[Hp]	[A]	l/min	0	333	667	1000	1333	1667	2000	2333	2667	3000	3333	3500
				l/sec	0	6	11	17	22	28	33	39	44	50	56	58
				m³/h	0	20	40	60	80	100	120	140	160	180	200	210
VS 160/1	15	20	32		32	32	32	30	28	26	24	22	20	18	15	13
VS 160/2	30	40	66.4		64	64	63	61	56	52	48	44	41	36	30	26
VS 160/3	37	50	82.2		97	96	95	91	84	78	72	67	61	54	44	38
VS 160/4	55	75	114		129	128	126	121	112	104	96	89	82	72	59	51
VS 160/5	75	100	150.7		161	160	158	152	140	129	120	111	102	89	74	64
VS 160/7	93	125	188		193	192	189	182	168	155	144	133	123	107	89	77
VS 160/9	110	150	226		258	256	252	243	224	207	192	178	164	143	118	102
VS 160/11	132	175	260		354	352	347	334	308	285	264	244	225	197	163	141
VS 160/12	147	200	294		387	384	379	364	336	311	288	267	245	215	177	153
VS 160/14	170	225	322.3		451	448	442	425	392	362	336	311	285	250	207	179
VS 160/15	190	250	390		483	480	473	455	420	388	360	333	307	268	222	192

OVERALL DIMENSIONS & WEIGHT 尺寸和重量

MODEL 型号	A [mm]	B [mm]	C [mm]	DN [mm]	H [mm]	M [mm]	Max [mm]	W [kg]	P [kg]	V [m³/sec]
VS 160/1	1436	651	785	6"	1200	145	218	59	82	0.5
VS 160/2	1857	807	1050	6"	1200	145	218	85	109	0.5
VS 160/3	2143	963	1180	6"	1200	145	218	98	170	0.5
VS 160/4	2469	1119	1350	6"	1200	192	227	192	245	0.5
VS 160/5	2865	1275	1590	6"	1200	192	227	237	287	0.5
VS 160/7	3417	1587	1830	6"	1200	192	227	283	354	0.5
VS 160/9	3959	1899	2060	6"	1200	192	227	333	416	0.5
VS 160/11	4429	2559	1870	6"	1200	232	237	435	550	0.5
VS 160/12	4784	2714	2070	6"	1200	232	237	500	621	0.5
VS 160/14	5245	3025	2220	6"	1200	232	237	540	673	0.5
VS 160/15	5929	3529	2400	6"	1200	232	237	580	781	0.5

W: Motor weight P: Pump weight(Include motor)
W: 电机重量 P: 水泵总重(含电机)

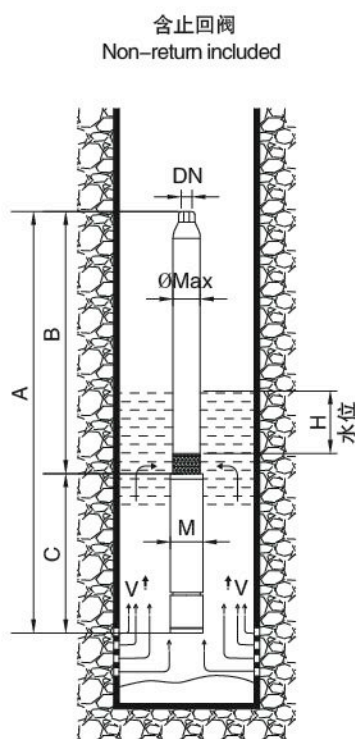

STAMPING SS SUBMERSIBLE PUMP

10" VS SERIES / 冲压不锈钢潜水泵 VS系列

PERFORMANCE CURVE CHART 性能曲线图

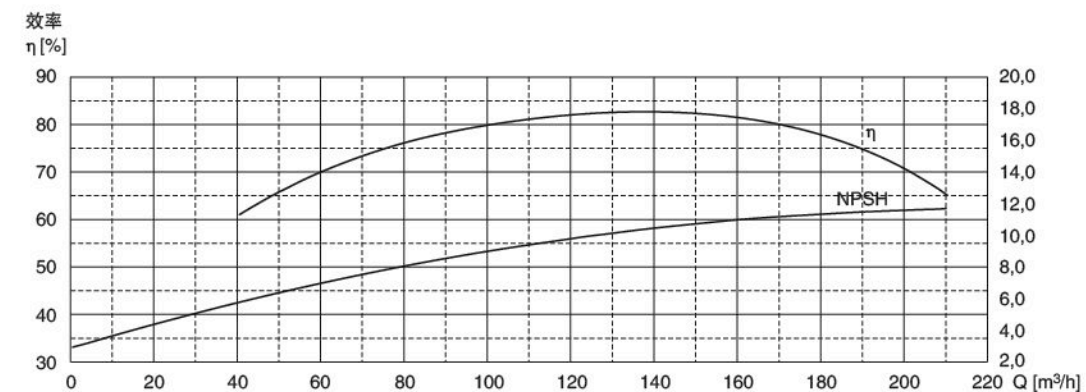
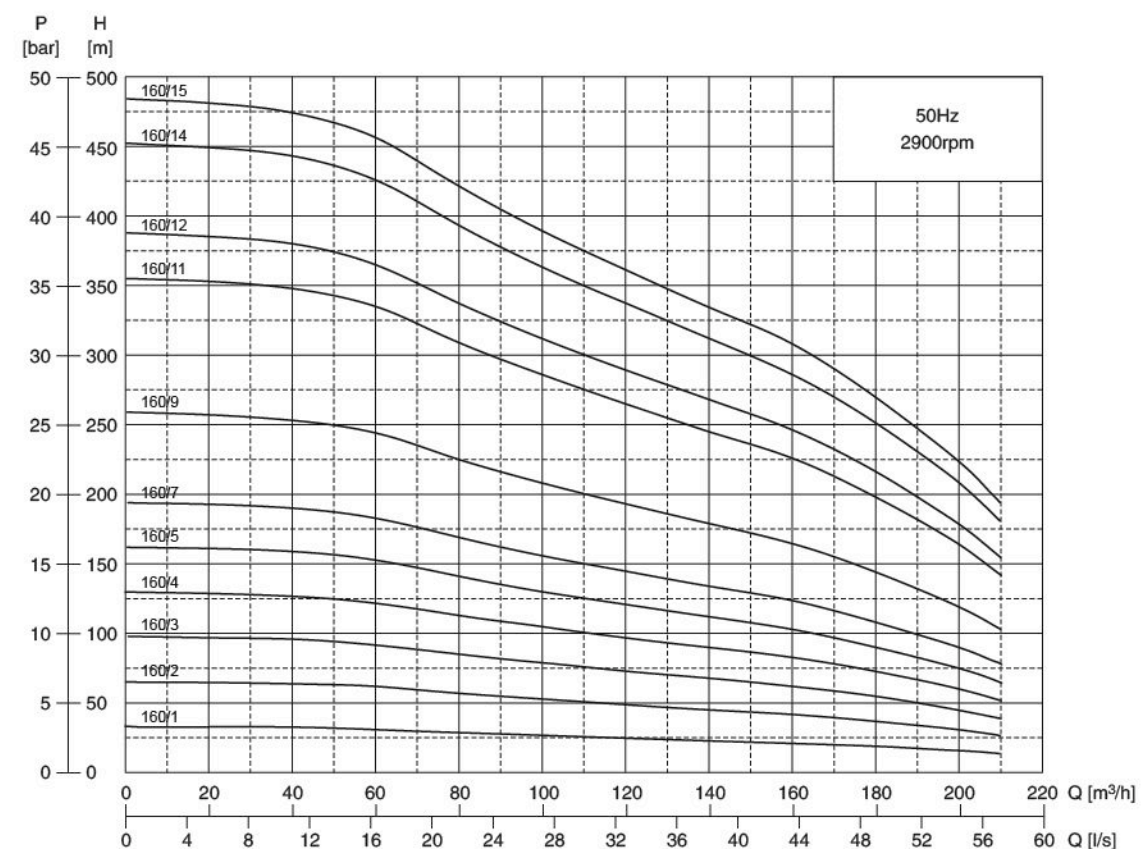

- VS
- VS 1
- VS 2
- VS 3
- VS 5
- VS 8
- VS 13
- VS 17
- VS 30
- VS 45
- VS 60
- VS 75
- VS 95
- VS 125
- VS 160
- VS 210
- VN
- VN 3
- VN 5
- VN 9
- VL
- VL 3
- VL 5
- VL 9
- OTHERS

STAMPING SS SUBMERSIBLE PUMP

10" VS SERIES / 冲压不锈钢潜水泵 VS系列

TECHNICAL SPECIFICATION 技术参数

MODEL 型号	MOTOR 电机			TOTAL MANOMETRIC HEAD HMT 扬程 [m]	0	1320	1680	1980	2340	2640	3000	3360	3660	4020	4320	4680		
	[Kw]	[Hp]	[A]		l/min	l/sec	m ³ /h	0	22	28	33	39	44	50	56	61	67	72
VS 210/1	18.5	25	40	40	36	34	33	31	29	27	26	24	21	18	14			
VS 210/2	45	60	93	80	72	68	65	61	58	55	51	47	42	35	28			
VS 210/3	75	100	154	120	108	103	98	92	86	82	77	71	62	53	42			
VS 210/4	75	100	154	160	144	137	130	122	115	110	102	94	83	70	56			
VS 210/5	93	125	188	200	180	171	163	153	144	137	128	118	104	88	70			
VS 210/6	110	150	226	240	216	205	195	183	173	164	154	141	125	106	84			
VS 210/7	132	175	260	280	252	239	228	214	202	192	179	165	146	123	98			
VS 210/8	147	200	294	320	288	274	260	244	230	219	205	188	166	141	112			
VS 210/9	170	225	322.3	360	324	308	293	275	259	247	230	212	187	158	126			
VS 210/10	190	250	390	400	360	342	325	305	288	274	256	235	208	176	140			

OVERALL DIMENSIONS & WEIGHT 尺寸和重量

MODEL 型号	A [mm]	B [mm]	C [mm]	DN [mm]	H [mm]	M [mm]	Max [mm]	W [kg]	P [kg]	V [m ³ /sec]
VS 210/1	1650	790	860	6"	1200	145	247	66	97	0.5
VS 210/2	2236	966	1270	6"	1200	192	247	177	228	0.5
VS 210/3	2732	1142	1590	6"	1200	192	247	237	279	0.5
VS 210/4	2908	1318	1590	6"	1200	192	247	237	308	0.5
VS 210/5	3324	1494	1830	6"	1200	192	247	283	364	0.5
VS 210/6	3730	1670	2060	6"	1200	192	247	333	424	0.5
VS 210/7	4016	2146	1870	6"	1200	232	247	435	536	0.5
VS 210/8	4392	2322	2070	6"	1200	232	247	500	611	0.5
VS 210/9	5718	2498	3220	6"	1200	232	247	540	661	0.5
VS 210/10	5074	2674	2400	6"	1200	232	247	580	717	0.5

W: Motor weight P: Pump weight(Include motor)
W: 电机重量 P: 水泵总重(含电机)

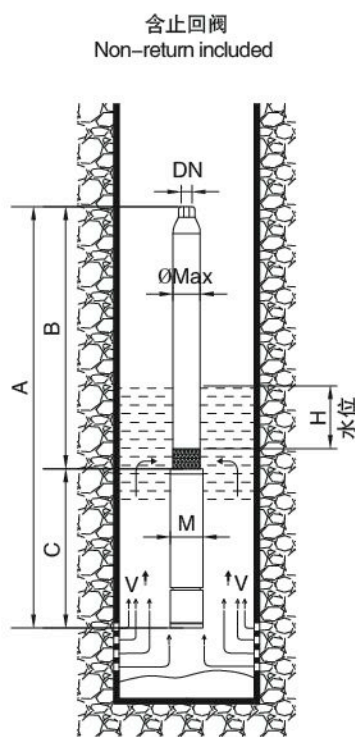

STAMPING SS SUBMERSIBLE PUMP

10" VS SERIES / 冲压不锈钢潜水泵 VS系列

PERFORMANCE CURVE CHART 性能曲线图

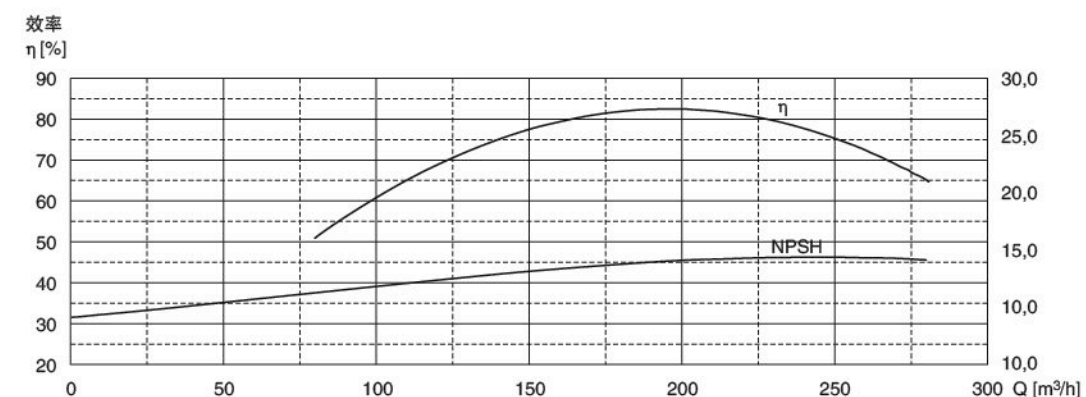
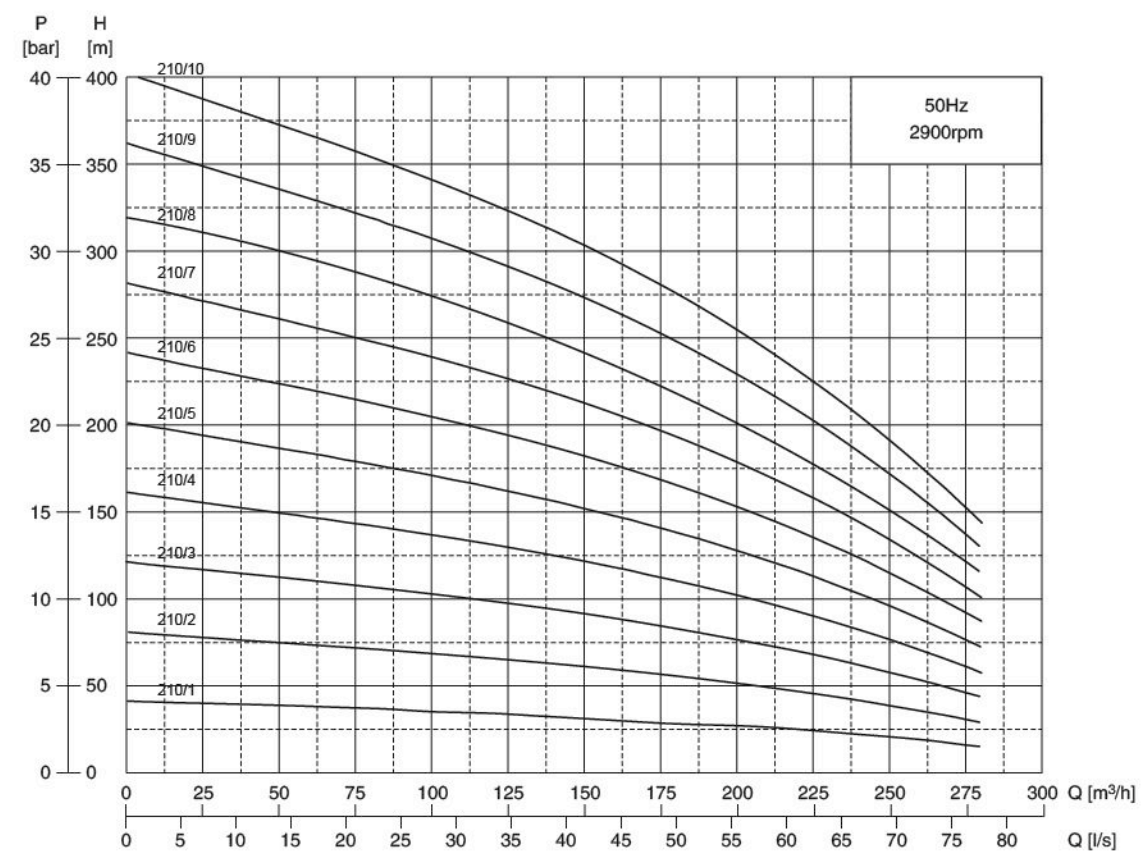

- VS
- VS 1
- VS 2
- VS 3
- VS 5
- VS 8
- VS 13
- VS 17
- VS 30
- VS 45
- VS 60
- VS 75
- VS 95
- VS 125
- VS 160
- VS 210
- VN
- VN 3
- VN 5
- VN 9
- VL
- VL 3
- VL 5
- VL 9
- OTHERS

STAMPING SS SUBMERSIBLE PUMP VN SERIES



I、Introduction

VN series stainless steel direct-connected multi-stage submersible pump, apply to 5" and above deep well, water pool, water tank and boost. VN series have a wide application range and adopt advanced laser cutting and welding process.

VN 系列不锈钢直联多级潜水泵，适用于 5 寸和较大深井、水池、水箱增压。该系列水泵应用范围较广，且采用了最先进的激光切割和激光焊接工艺技术制造而成。

AVAILABLE ON REQUEST 根据要求可提供

Single-phase pump equipped with floater	带浮球的单相水泵
Various voltages and frequencies	不同电压和频率
Various cable lengths	不同的电缆长度

STAMPING SS SUBMERSIBLE PUMP

VN SERIES / 冲压不锈钢潜水泵 VN系列

II、FEATURES 特点

- 1、Compact and closed structure design ensures durability, solidity and rust protection.
- 2、Impellers and diffusers are made of stainless steel in order to achieve durability, superior efficiency and the highest performances.
- 3、Double mechanical seal separated by an oil chamber for maximum motor protection.
- 4、Plug-in type power cable and floating ball(floater) for easy replacement.
- 5、Motor shaft can bear bigger axial load.
- 6、Stainless steel waterproof casing for maximum motor protection.
- 7、The motor is cooled by the pumped liquid.

- 1、紧凑密闭的设计，坚固耐用且防锈。
- 2、叶轮和导叶均由不锈钢材料制造，耐磨高效。
- 3、双机械密封被油室隔开在最大程度上保护了电机。
- 4、电缆和浮球均易更换。
- 5、电机轴可承受较大轴向力。
- 6、不锈钢防水外壳充分保护电机。
- 7、电机由水泵本身抽取水冷却。

III、TECHNICAL SPECIFICATION 技术参数

Capacities up to 14m ³ /h(50Hz) 70GPM(60Hz)	最大流量可达14m ³ /h(50Hz) 70GPM(60Hz)
Heads up to 11bar(50Hz) 370 foot (60Hz)	最大扬程达11bar(50Hz) 370英尺 (60Hz)
Maximum working pressure: 15 Bar	最大工作压力15 bar
Maximum submergeel depth: 20 m	最大入水深度20m
Maximum sediment concentration:50g/m ³	最大含沙量50g/m ³
Maximum solid particle diameter:2mm	最大固体颗粒直径2mm
Liquid temperature range: from -5℃ to +40℃	水温范围-5℃-40℃
Protection Grade IP 68	防护等级IP68

IV、MODEL DESCRIPTION 型号说明

VN 3 8 T 6		
	60Hz(None for 50Hz)	60Hz (没有即为50Hz)
	Three phase (none for single phase)	三相 (没有即为单相)
	Number of stages	级数
	Rated capacity: (m ³ /h)	额定流量 (m ³ /h)
	Pump Model	水泵类型

VS

VS 1

VS 2

VS 3

VS 5

VS 8

VS 13

VS 17

VS 30

VS 45

VS 60

VS 75

VS 95

VS 125

VS 160

VS 210

VN

VN 3

VN 5

VN 9

VL

VL 3

VL 5

VL 9

OTHERS

STAMPING SS SUBMERSIBLE PUMP

VN SERIES / 冲压不锈钢潜水泵
VN系列

V、PERFORMANCE CHART 型谱图

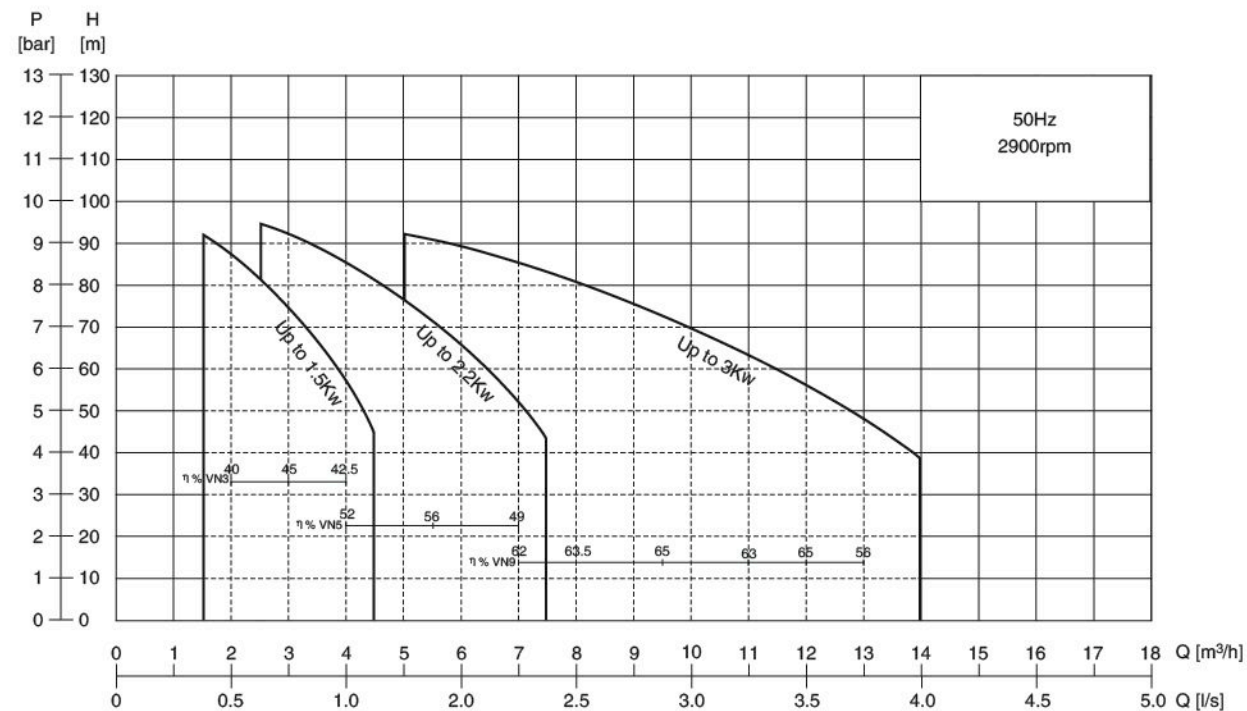

VI、MATERIAL DESCRIPTION 材料说明

部件名称	PART DESCRIPTION	MATERIAL 材质
外壳	Outer case	Stainless steel DIN-EN 1.4301(AISI 304)
滤网	Suction strainer	Stainless steel DIN-EN 1.4301(AISI 304)
电机外壳	Motor housing	Stainless steel DIN-EN 1.4301(AISI 304)
端盖	Covers/flanges motor casing	Stainless steel DIN-EN 1.4301(AISI 304)
泵轴	Pump shaft	Stainless steel DIN-EN 1.4301(AISI 304)
导叶	Diffuser/s	Stainless steel DIN-EN 1.4301(AISI 304)
叶轮	Impeller/s	Stainless steel DIN-EN 1.4301(AISI 304)
螺栓和垫圈	Screws and washers	Stainless steel DIN-EN 1.4301(AISI 304)
出水口	Discharge head	Nickel plated pressed brass alloy (镀镍铜合金) UNI-EN 1265-98
上机械密封	Upper mechanical seal	Ceramic/Carbon/NBR (陶瓷/石墨)
下机械密封	Lower mechanical seal	Ceramic/Carbon/NBR (陶瓷/石墨)

STAMPING SS SUBMERSIBLE PUMP

VN SERIES / 冲压不锈钢潜水泵
VN系列

VII、PUMP CONSTRUCTION 水泵结构

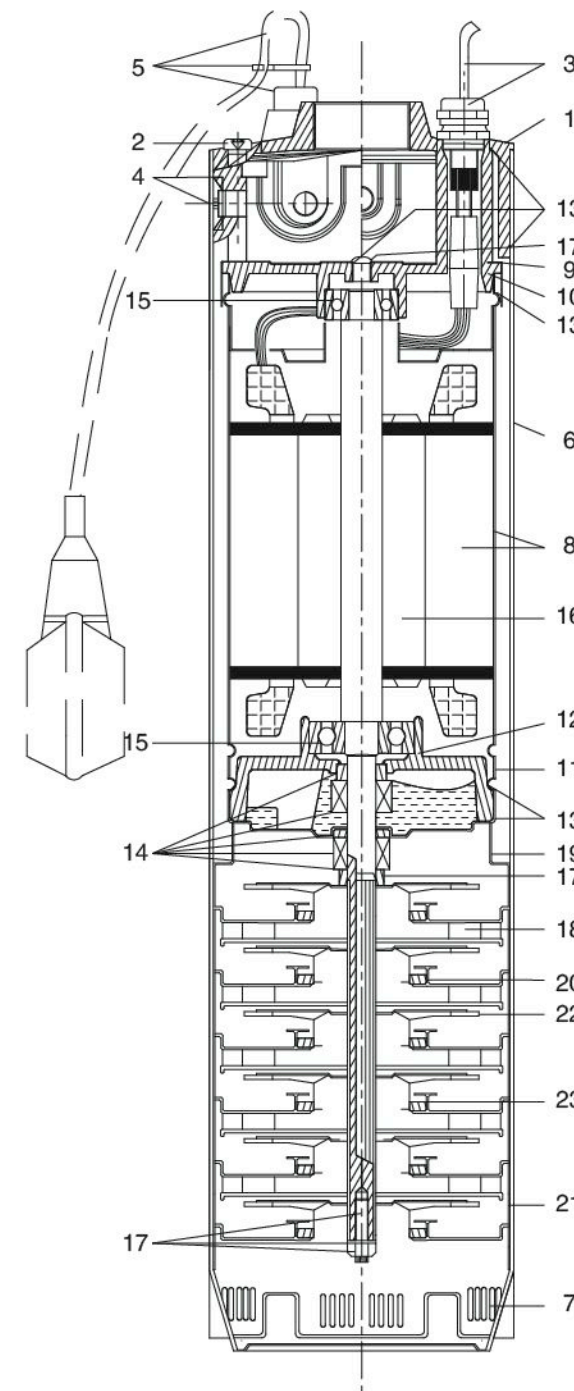

Ref.N.	DESCRIPTION	名称	材质
1	Body	阀体	304SS
2	Nut	螺母	304SS
3	Cable block	电缆座	304SS
4	Screw and bolt	螺丝和插销	304SS
5	Level control device	液体控制装置	304SS
6	Casing	外壳	304SS
7	Suction	吸入口	304SS
8	Suction and stator	电机室和定子	304SS
9	Upper motor cover	上电机盖	304SS
10	Upper shaft cover	上轴承盖	304SS
11	Lower motor cover	下电机盖	304SS
12	Lower shaft cover	下轴承盖	304SS
13	O-ring	O型密封装置 (5个)	NBR
14	Mechanical seal	机械密封装置 (2个)	NBR
15	Shaft (ball)	轴承 (滚珠)	NBR
16	Rotor and pump shaft	转子和泵轴	304SS
17	Impeller Locknut	锁紧螺母	304SS
18	Rotor and defuser	转子和导叶	304SS
19	Sleeve	轴套	304SS
20	Neck ring	颈环装置	304SS
21	Last diffuser	末级导壳	304SS
22	Impeller	叶轮	304SS
23	Impeller sleeve	叶轮轴套 (2件)	304SS

VS
VS 1
VS 2
VS 3
VS 5
VS 8
VS 13
VS 17
VS 30
VS 45
VS 60
VS 75
VS 95
VS 125
VS 160
VS 210
VN
VN 3
VN 5
VN 9
VL
VL 3
VL 5
VL 9
OTHERS

STAMPING SS SUBMERSIBLE PUMP

VN SERIES / 冲压不锈钢潜水泵
VN系列

TECHNICAL SPECIFICATION 技术参数

MODEL 型号	NUMBER OF STAGES 级数	MOTOR POWER 电机功率		INPUT POWER 输入功率	CAPACITOR 电容器		RATED CURRENT 额定电流	
		[Kw]	[Hp]		[μ F]	[V]	Single-phase 单相 220-240V50Hz	Three-phase 三相 380-415V50Hz
VN 3/4	-	0.55	0.75	0.85	16	450	4	-
VN 3/5	-	0.75	1	1	20	450	4.8	-
VN 3/6	-	0.75	1	1.2	20	450	5.6	-
VN 3/7	-	1.1	1.5	1.35	30	450	6.3	-
VN 3/8	VN 3/8T	1.1	1.5	1.55	30	450	7.2	2.75
VN 3/9	VN 3/9T	1.5	2	1.8	35	450	8.7	3.2
VN 3/10	VN 3/10T	1.5	2	2	35	450	9.7	3.5

Single-phase motor :220-240V ± 5%/50Hz. Thermal protection built into the motor up to 1.1Kw. Thermal protection provided into the starter panel from 1.5Kw and above.

Three-phase motors:380-415V ± 5%/50Hz Thermal protection to be provide into the starter panel by the installer.

单相电机：220-240V ± 5%/50Hz，1.1Kw 内热保护电机内置。1.5Kw 以上控制箱提供热保护。

三相电机：380-415V ± 5%/50Hz，控制箱提供热保护。

MODEL 型号	PACKAGING 包装				WEIGHT 重量			
	Single-phase 单相 220-240V50Hz	Three-phase 三相 380-415V50Hz	Lt [mm]	L [mm]	B [mm]	H [mm]	Single-phase 单相 [Kg]	Three-phase 三相 [Kg]
VN 3/4	-	-	456	720	230	175	16.0	-
VN 3/5	-	-	480	720	230	175	18.0	-
VN 3/6	-	-	504	720	230	175	18.5	-
VN 3/7	-	-	528	720	230	175	20.0	-
VN 3/8	-	VN 3/8T	552	720	230	175	20.5	19.5
VN 3/9	-	VN 3/9T	576	800	230	195	23.5	21.5
VN 3/10	-	VN 3/10T	650	800	230	195	24.0	22

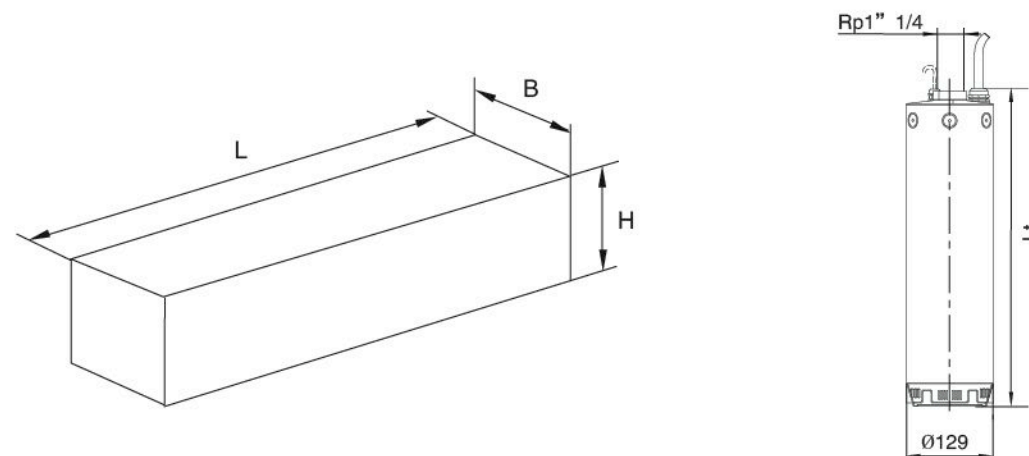

STAMPING SS SUBMERSIBLE PUMP

VN SERIES / 冲压不锈钢潜水泵
VN系列

PERFORMANCE CURVE CHART 性能曲线图

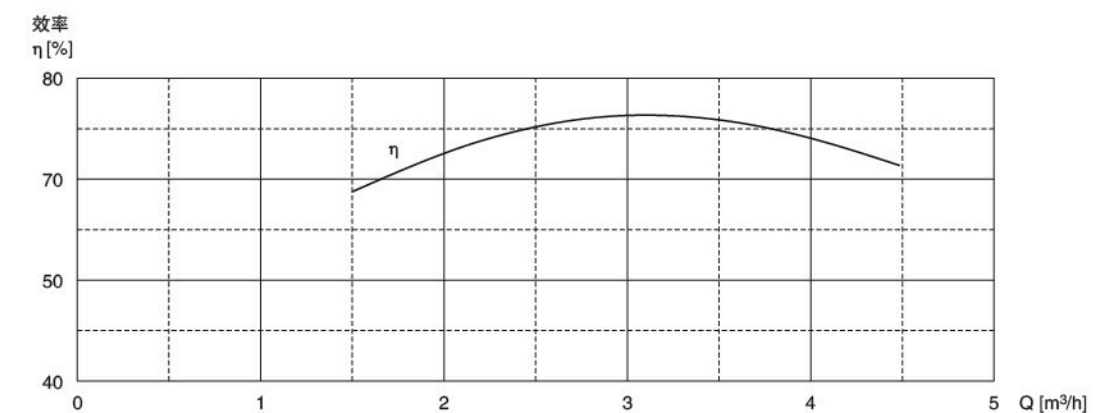
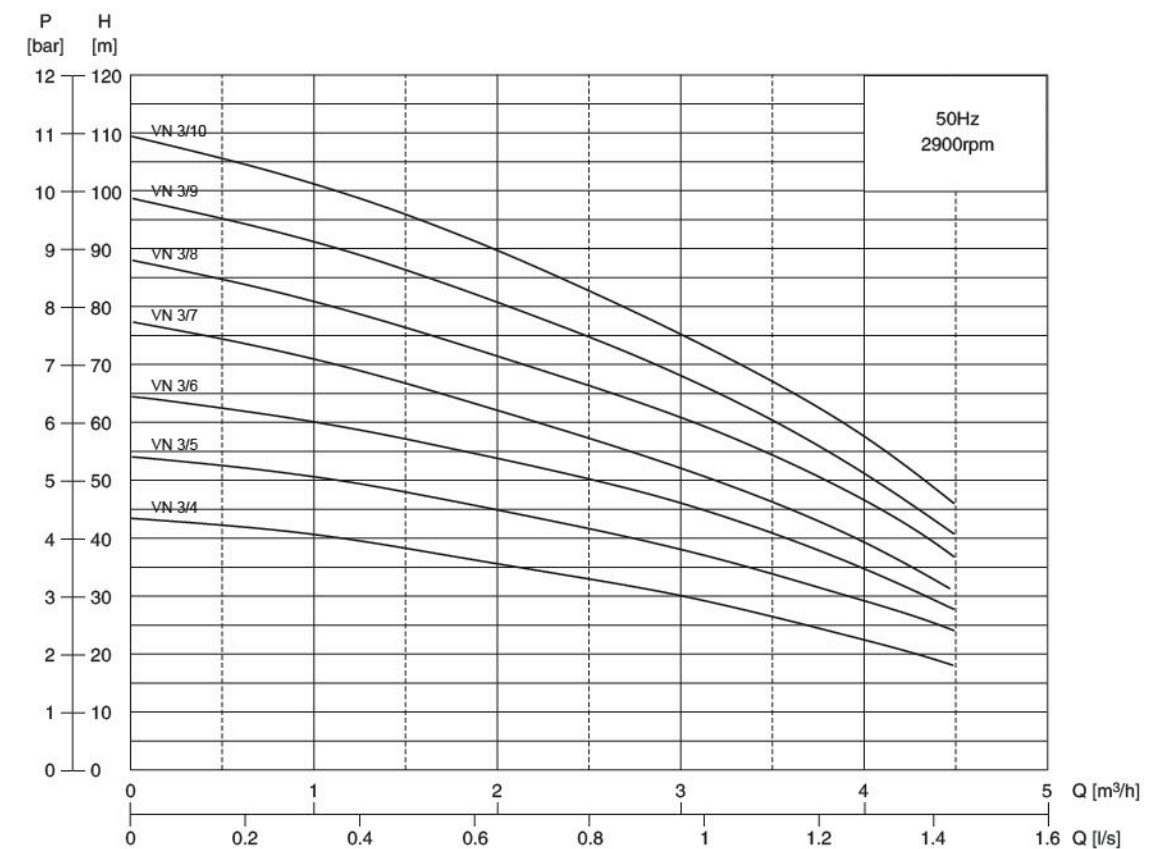

VS

VS 1

VS 2

VS 3

VS 5

VS 8

VS 13

VS 17

VS 30

VS 45

VS 60

VS 75

VS 95

VS 125

VS 160

VS 210

VN

VN 3

VN 5

VN 9

VL

VL 3

VL 5

VL 9

OTHERS

STAMPING SS SUBMERSIBLE PUMP

VN SERIES / 冲压不锈钢潜水泵
VN系列

TECHNICAL SPECIFICATION 技术参数

MODEL 型号	NUMBER OF STAGES 级数		MOTOR POWER 电机功率		INPUT POWER 输入功率	CAPACITOR 电容器		RATED CURRENT 额定电流	
	Single-phase 单相 220-240V50Hz	Three-phase 三相 380-415V50Hz	[Kw]	[Hp]		[μ F]	[V]	Single-phase 单相 220-240V50Hz	Three-phase 三相 380-415V50Hz
VN 5/4	-	4	0.75	1	1.15	20	450	5.4	-
VN 5/5	-	5	1.1	1.5	1.4	30	450	6.5	-
VN 5/6	VN 5/6T	6	1.1	1.5	1.65	30	450	7.6	2.8
VN 5/7	VN 5/7T	7	1.5	2	1.95	35	450	9.5	3.3
VN 5/8	VN 5/8T	8	1.5	2	2.2	35	450	10.5	3.8
VN 5/9	VN 5/9T	9	2	3	2.4	45	450	11.2	4.4
VN 5/10	VN 5/10T	10	2	3	2.65	45	450	12.3	4.8

Single-phase motor :220-240V ± 5%/50Hz. Thermal protection built into the motor up to 1.1Kw. Thermal protection provided into the starter panel from 1.5Kw and above.

Three-phase motors:380-415V ± 5%/50Hz Thermal protection to be provide into the starter panel by the installer.

单相电机：220-240V ± 5%/50Hz，1.1Kw 内热保护电机内置。1.5Kw 以上控制箱提供热保护。

三相电机：380-415V ± 5%/50Hz，控制箱提供热保护。

MODEL 型号	PACKAGING 包装				WEIGHT 重量			
	Single-phase 单相 220-240V50Hz	Three-phase 三相 380-415V50Hz	Lt [mm]	L [mm]	B [mm]	H [mm]	Single-phase 单相 [Kg]	Three-phase 三相 [Kg]
VN 5/4	-	-	480	720	230	175	17.5	-
VN 5/5	-	-	504	720	230	175	19.0	-
VN 5/6	VN 5/6T	-	528	720	230	175	19.5	18.5
VN 5/7	VN 5/7T	-	602	800	230	195	22.5	20.5
VN 5/8	VN 5/8T	-	626	800	230	195	23.0	21.0
VN 5/9	VN 5/9T	-	650	800	230	195	25.0	23.5
VN 5/10	VN 5/10T	-	674	800	230	195	25.5	24.0

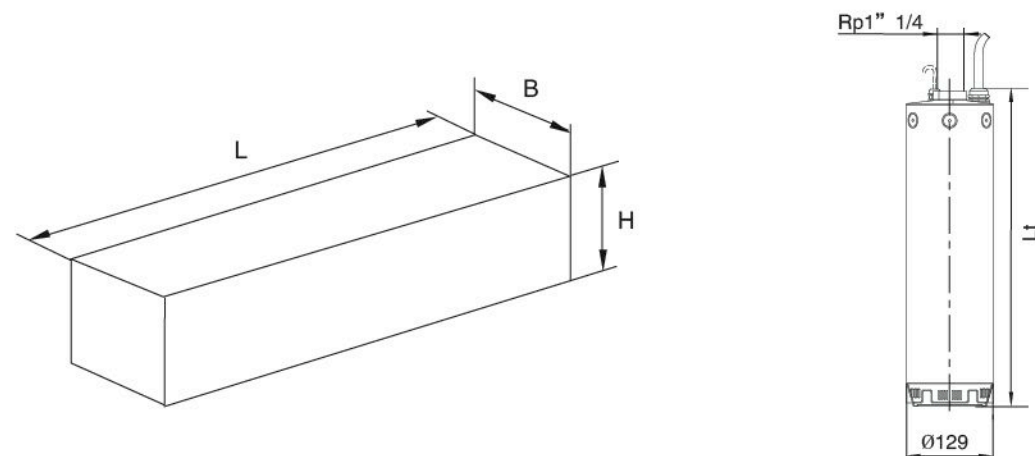

STAMPING SS SUBMERSIBLE PUMP

VN SERIES / 冲压不锈钢潜水泵
VN系列

PERFORMANCE CURVE CHART 性能曲线图

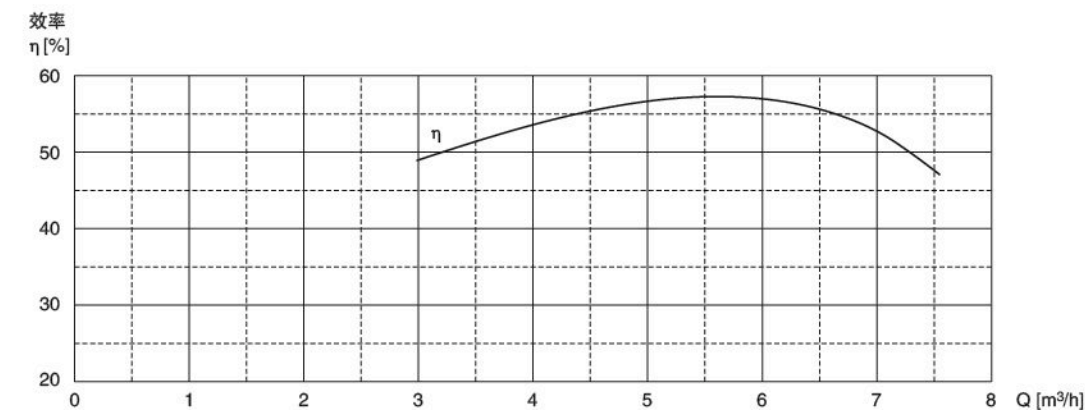
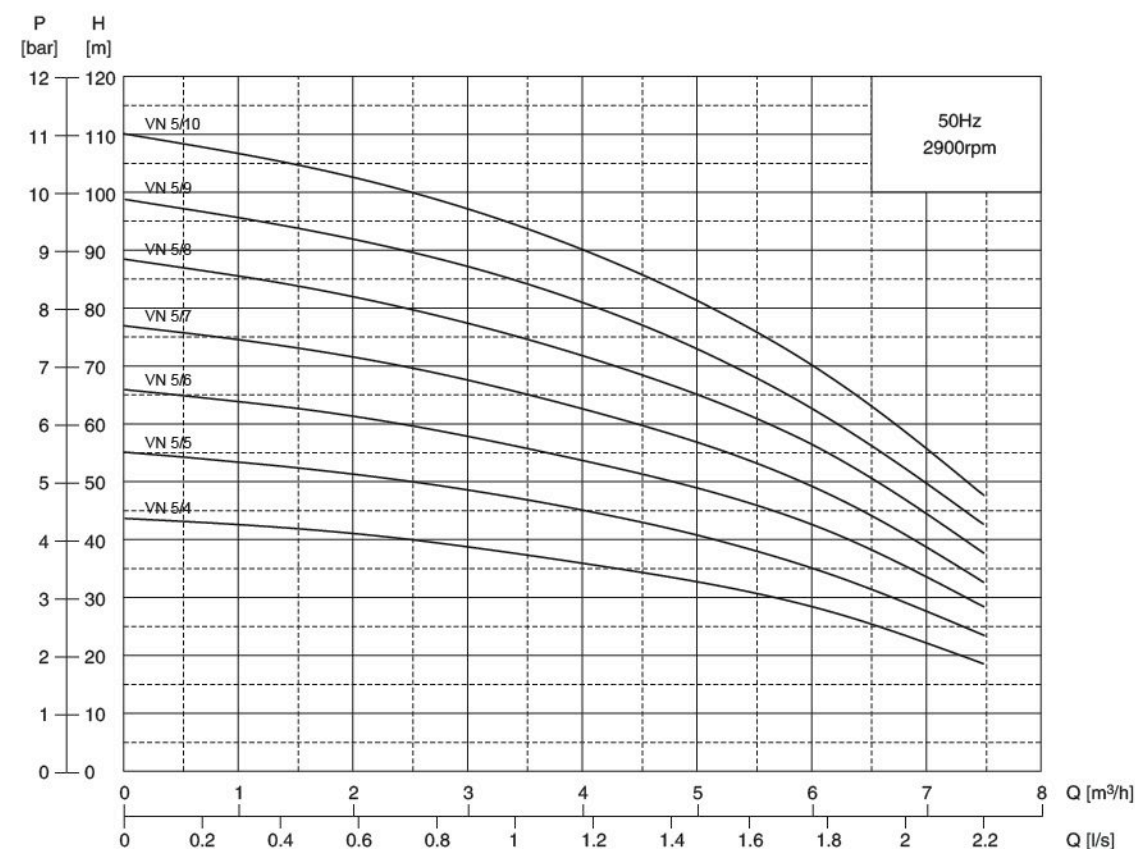

- VS
- VS 1
- VS 2
- VS 3
- VS 5
- VS 8
- VS 13
- VS 17
- VS 30
- VS 45
- VS 60
- VS 75
- VS 95
- VS 125
- VS 160
- VS 210
- VN
- VN 3
- VN 5
- VN 9
- VL
- VL 3
- VL 5
- VL 9
- OTHERS

STAMPING SS SUBMERSIBLE PUMP

VN SERIES / 冲压不锈钢潜水泵
VN系列

TECHNICAL SPECIFICATION 技术参数

MODEL 型号	NUMBER OF STAGES 级数	MOTOR POWER 电机功率		INPUT POWER 输入功率	CAPACITOR 电容器		RATED CURRENT 额定电流	
		[Kw]	[Hp]		[μ F]	[V]	Single-phase 单相 220-240V50Hz	Three-phase 三相 380-415V50Hz
VN 9/3	-	1.1	1.5	1.4	30	450	6.5	-
VN 9/4	VN 9/4T	1.5	2	1.9	35	450	9.2	3.25
VN 9/5	VN 9/5T	2.2	3	2.3	45	450	10.8	4.1
VN 9/6	VN 9/6T	2.2	3	2.6	45	450	12.2	4.7
-	VN 9/7T	3	4	3	-	-	-	5.9
-	VN 9/8T	3	4	3.4	-	-	-	6.5
-	VN 9/9T	3	4	3.8	-	-	-	7

Single-phase motor :220-240V ± 5%/50Hz. Thermal protection built into the motor up to 1.1Kw. Thermal protection provided into the starter panel from 1.5Kw and above.

Three-phase motors:380-415V ± 5%/50Hz Thermal protection to be provide into the starter panel by the installer.

单相电机：220-240V ± 5%/50Hz，1.1Kw 内热保护电机内置。1.5Kw 以上控制箱提供热保护。

三相电机：380-415V ± 5%/50Hz，控制箱提供热保护。

MODEL 型号	PACKAGING 包装	WEIGHT 重量	
		Single-phase 单相 220-240V50Hz	Three-phase 三相 380-415V50Hz
VN 9/3	-	18.5	-
VN 9/4	VN 9/4T	21.5	19.0
VN 9/5	VN 9/5T	23.5	22.0
VN 9/6	VN 9/6T	24.0	22.5
-	VN 9/7T	-	24.5
-	VN 9/8T	-	25.0
-	VN 9/9T	-	25.5

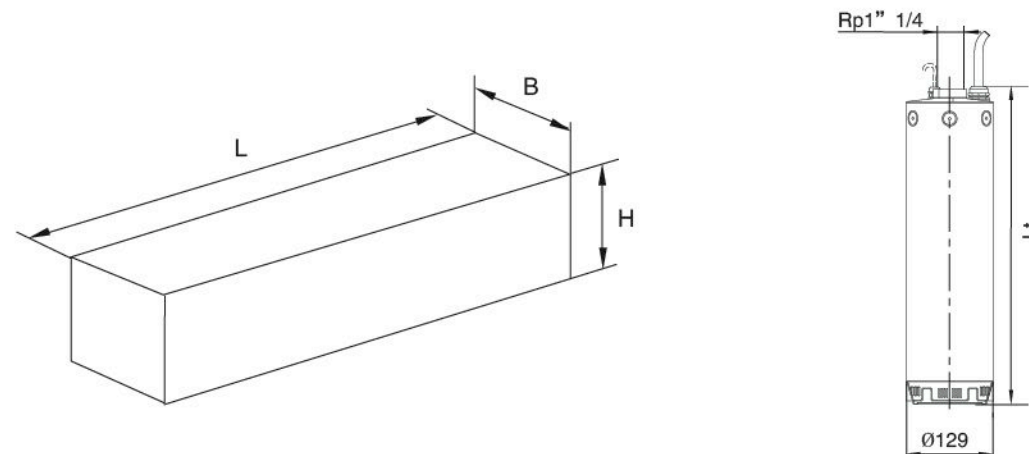

STAMPING SS SUBMERSIBLE PUMP

VN SERIES / 冲压不锈钢潜水泵
VN系列

PERFORMANCE CURVE CHART 性能曲线图

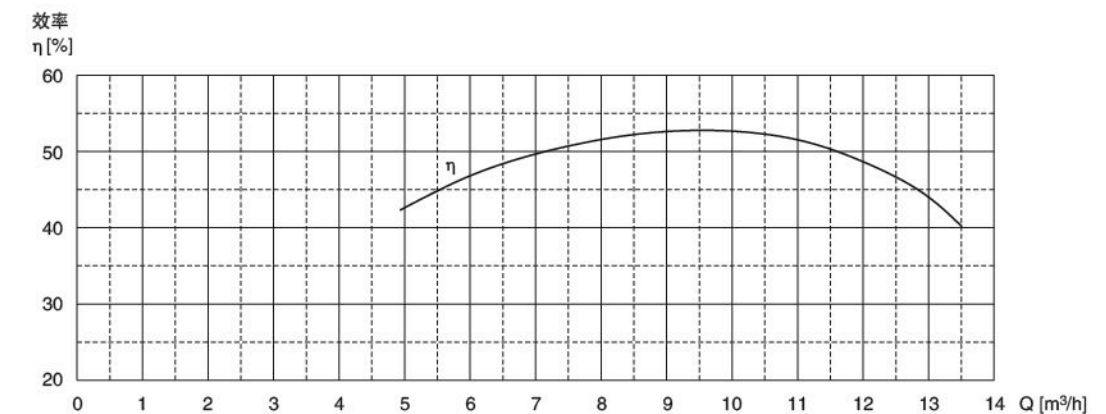
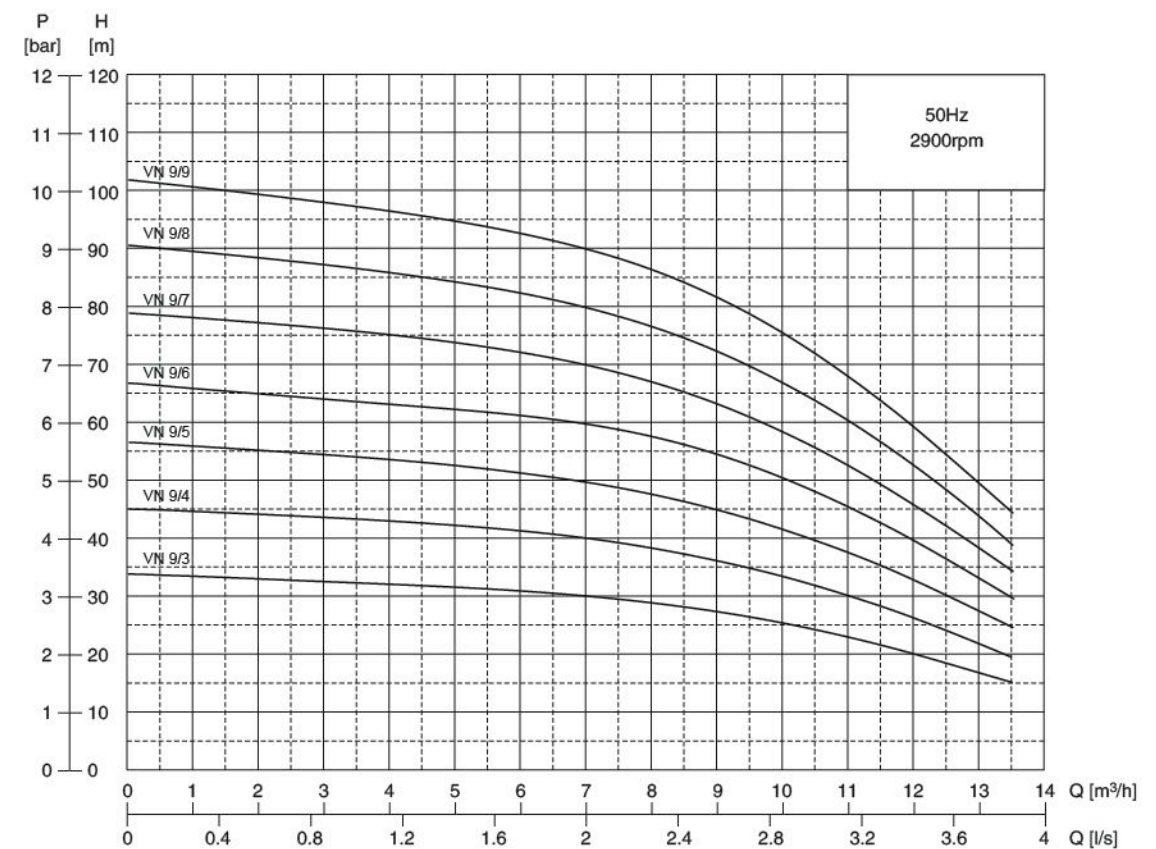

- VS
- VS 1
- VS 2
- VS 3
- VS 5
- VS 8
- VS 13
- VS 17
- VS 30
- VS 45
- VS 60
- VS 75
- VS 95
- VS 125
- VS 160
- VS 210
- VN
- VN 3
- VN 5
- VN 9**
- VL
- VL 3
- VL 5
- VL 9
- OTHERS

STAMPING SS SUBMERSIBLE PUMP VL SERIES

STAMPING SS SUBMERSIBLE PUMP VL SERIES / 冲压不锈钢潜水泵 VL系列



VL

I、Introduction

Based on stainless steel submersible pump, VL integrated pump adopts advanced stainless steel production process, which is designed to widely used in different situations, especially for secondary pressurization in pipeline and narrow space.

VL 一体式电泵在常规不锈钢潜水泵的基础上进行二次开发, 采用最先进的不锈钢生产技术, 能更广泛的运用在各种场合, 特别适用于管道及狭小空间的二次增压。

II、FEATURES 特点

- 1、Improved VL series is a multifunctional pump which applies to water and ground. It adopts stainless steel material, compact in design and durable in use.
- 2、Impeller and defuser are made of stainless steel, wear-resistant and efficient.
- 3、Double mechanical seal is separated by the liquid chamber, which maximizes the motor protection.
- 4、Embedded cable and float are easy to replace.
- 5、The cooling water of the sealed motor is pumped by pump itself that makes no noise.
- 6、Pump adopts flange connection that makes it easier to install in a narrow space.

- 1、经过进一步改进的VL泵是多功能的泵, 水中和地面均适用, 全不锈钢材质, 紧凑设计, 坚固耐用。
- 2、叶轮和导叶均采用不锈钢制造, 耐磨高效。
- 3、双机械密封由液体室隔开, 最大程度上保护了电机。
- 4、嵌入式电缆和浮球均容易更换。
- 5、密封的电机由水泵抽取的水冷却, 无噪音。
- 6、泵采用法兰连接, 从而更容易安装在狭窄的空间。

III、TECHNICAL SPECIFICATION 技术参数

Maximum flow: 14m ³ /h	最大流量可达14m ³ /h
Maximum head: 11Bar	最大扬程达11bar
Outlet is 1" 1/4Rp	出水口为1" 1/4Rp
Inlet is 1" 1/2Rp	吸水口为1" 1/2Rp
Outlet and inlet is connected by elliptical flange which can be connected quickly.	出入口是椭圆法兰, 便于快速连接
Maximum working pressure: 15 Bar	最大工作压力15 bar
Maximum submerge depth: 20 m	最大入水深度20m
Liquid temperature range: from -5°C to +40°C	水温范围-5°C~+40°C
Asynchronous motor, insulation class F, protection grade IP68	异步电机, F级绝缘, 防护等级IP68
Motor range: 0.55Kw-3Kw	电机范围: 0.55Kw-3Kw
Voltage: Single-phase 220V-240V, ±5%, 50HZ;	电压: 单相220V-240V, ±5%, 50HZ;
Three-phase 380V-415V, ±5%, 50HZ	三相380V-415V, ±5%, 50HZ
Maximum starts per hour: 20 times	每小时最多启动次数: 20次
Pump can continuously operate on horizontal or vertical direction.	水泵能在水平或垂直方向连续运转

IV、MODEL DESCRIPTION 型号说明

VL 3 8 T 6

60Hz (None for 50Hz)	60Hz (没有即为50Hz)
Three phase (none for single phase)	三相 (没有即为单相)
Number of stages	级数
Rated capacity: (m ³ /h)	额定流量 (m ³ /h)
Pump Model	水泵型号

VS

VS 1

VS 2

VS 3

VS 5

VS 8

VS 13

VS 17

VS 30

VS 45

VS 60

VS 75

VS 95

VS 125

VS 160

VS 210

VN

VN 3

VN 5

VN 9

VL

VL 3

VL 5

VL 9

OTHERS

STAMPING SS SUBMERSIBLE PUMP

VL SERIES / 冲压不锈钢潜水泵 VL系列

V、PERFORMANCE CHART 型谱图

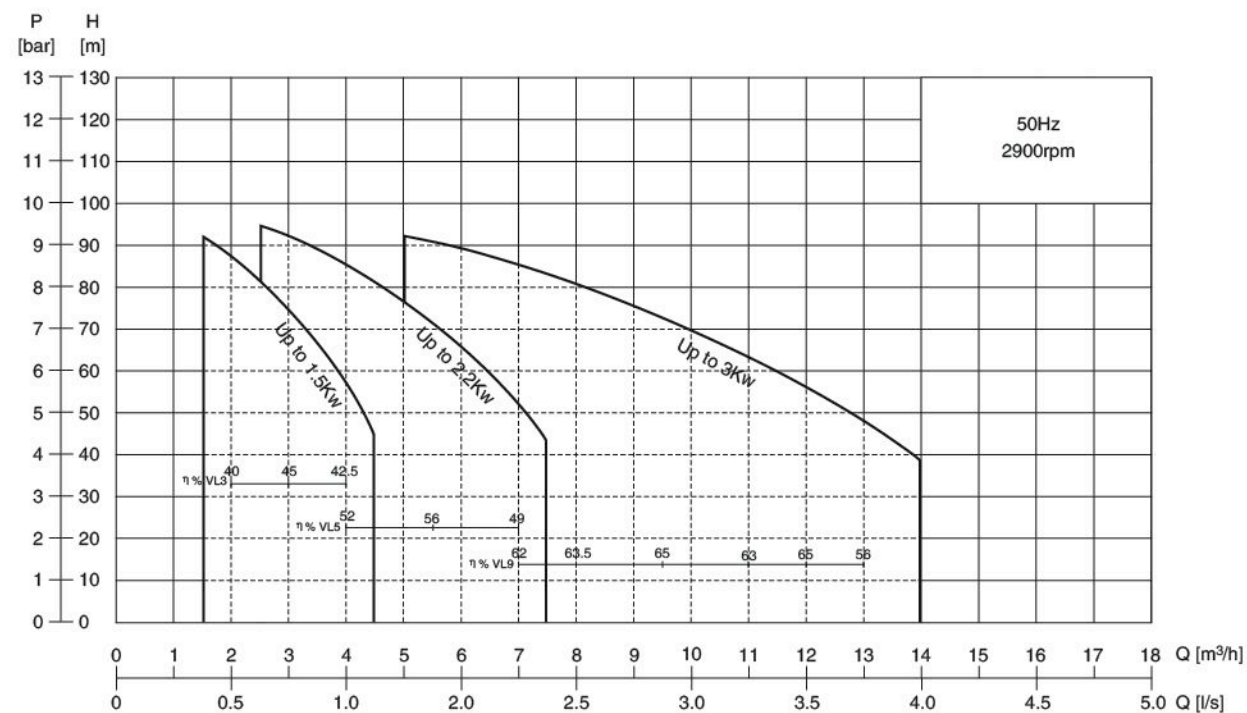

VI、MATERIAL DESCRIPTION 材料说明

部件名称	PART DESCRIPTION	MATERIAL 材质
外壳	Outer case	Stainless steel DIN-EN 1.4301(AISI 304)
滤网	Suction strainer	Stainless steel DIN-EN 1.4301(AISI 304)
电机外壳	Motor housing	Stainless steel DIN-EN 1.4301(AISI 304)
端盖	Covers/flanges motor casing	Stainless steel DIN-EN 1.4301(AISI 304)
泵轴	Pump shaft	Stainless steel DIN-EN 1.4301(AISI 304)
导叶	Diffuser/s	Stainless steel DIN-EN 1.4301(AISI 304)
叶轮	Impeller/s	Stainless steel DIN-EN 1.4301(AISI 304)
螺栓和垫圈	Screws and washers	Stainless steel DIN-EN 1.4301(AISI 304)
出水口	Discharge head	Nickel plated pressed brass alloy (镀镍铜合金) UNI-EN 1265-98
上机械密封	Upper mechanical seal	Ceramic/Carbon/NBR (陶瓷/石墨)
下机械密封	Lower mechanical seal	Ceramic/Carbon/NBR (陶瓷/石墨)

STAMPING SS SUBMERSIBLE PUMP

VL SERIES / 冲压不锈钢潜水泵 VL系列

VII、PUMP CONSTRUCTION 水泵结构

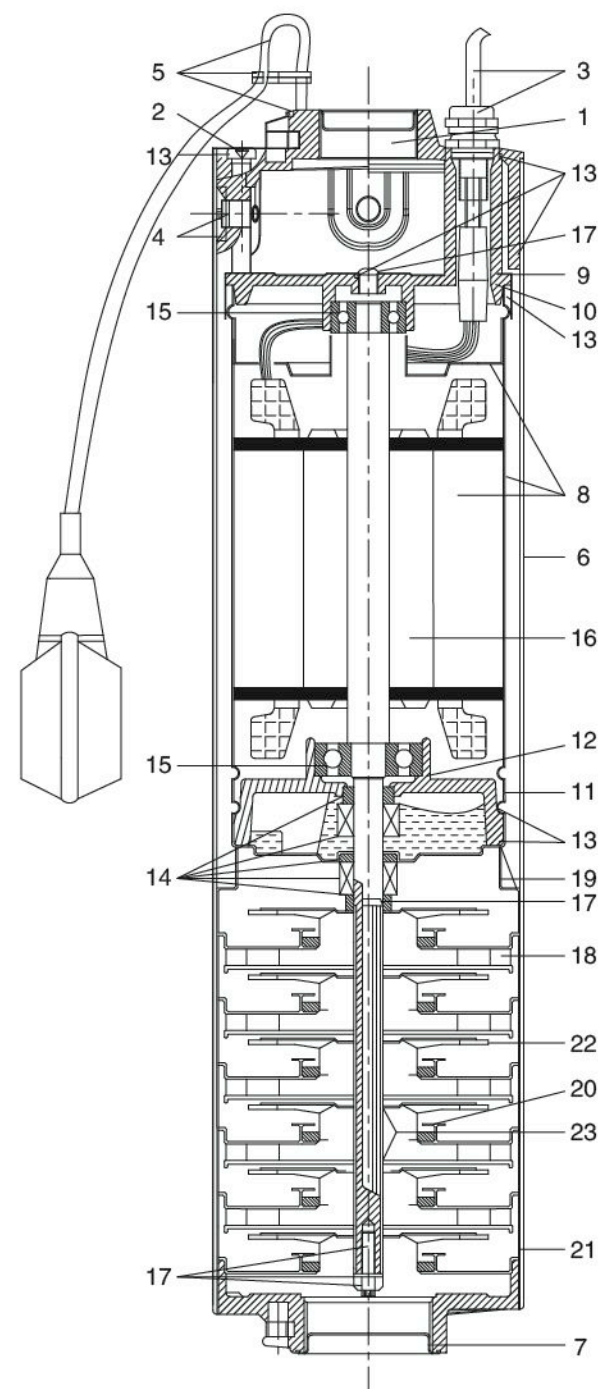

Ref.N.	DESCRIPTION	名称	材质
1	Outlet	出水口	304SS
2	Preloaded nut device	预载螺母装置 (3个)	304SS
3	Power cable assembly	电缆及电缆座	304SS
4	Screws and inserts	螺丝和定位销	304SS
5	Level control assembly	液体控制装置	304SS
6	Outer case with suction head	外壳	304SS
7	Suction inlet	吸入口	304SS
8	Motor housing and stator	电机室和定子	304SS
9	Upper motor cover	上电机盖	304SS
10	Upper bearing housing	上轴承盖	304SS
11	Lower motor cover	下电机盖	304SS
12	Lower bearing cover	下轴承盖	304SS
13	Kit O-Rings(5pcs)	O型密封装置 (5个)	NBR
14	Kit mechanical seal(2pcs)	机械密封装置 (2个)	NBR
15	Kit ball bearings(2pcs)	滚珠轴承 (2个)	NBR
16	Rotor and pump shaft	转子和泵轴	304SS
17	Kit screws,nut and washers	螺杆、螺母、垫圈	304SS
18	Defuser	导叶	304SS
19	Stage housing and diffuser	隔离装置	304SS
20	Floating neck ring assembly	颈环装置	304SS
21	Last diffuser	末级导壳	304SS
22	Impeller	叶轮	304SS
23	Impeller spacers	叶轮轴套	304SS

VS
VS 1
VS 2
VS 3
VS 5
VS 8
VS 13
VS 17
VS 30
VS 45
VS 60
VS 75
VS 95
VS 125
VS 160
VS 210
VN
VN 3
VN 5
VN 9
VL
VL 3
VL 5
VL 9
OTHERS

STAMPING SS SUBMERSIBLE PUMP

VL SERIES / 冲压不锈钢潜水泵 VL系列

PERFORMANCE CURVE CHART 性能曲线图

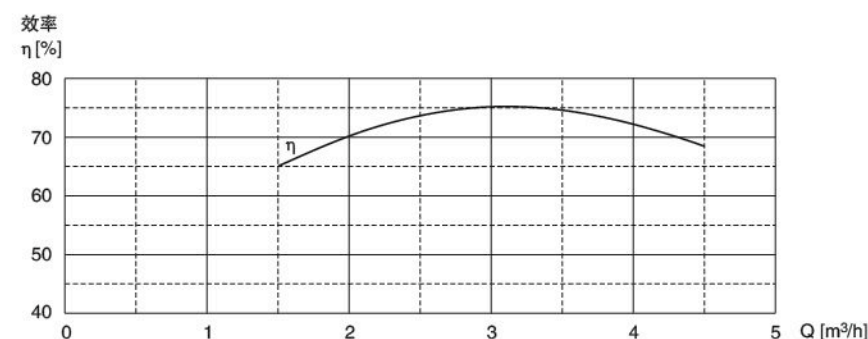
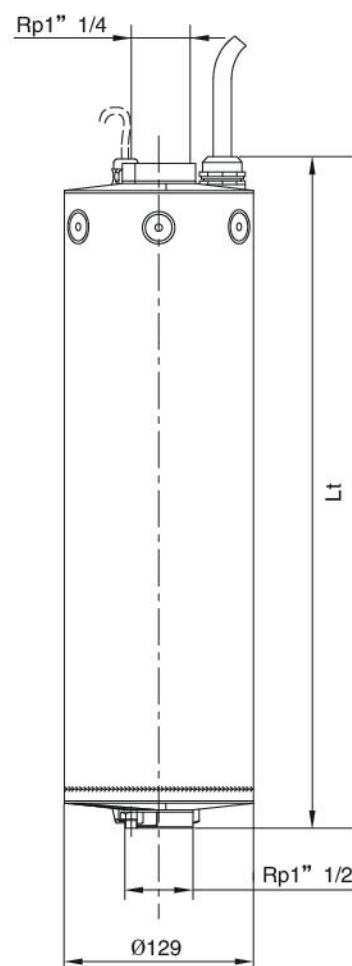
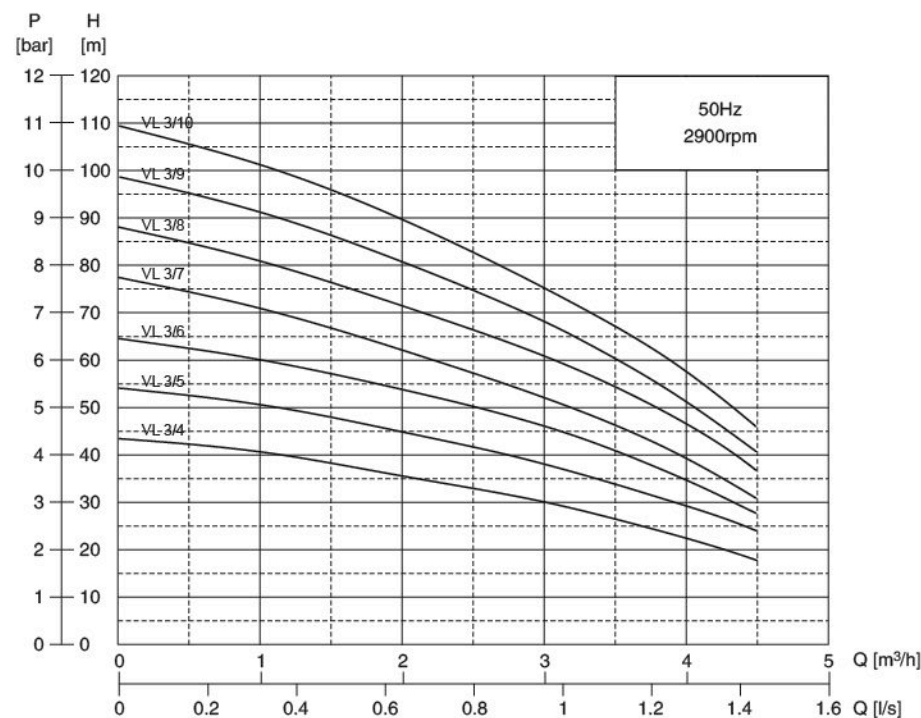

单相220V-240V/50Hz Single-phase	三相380V-415V/50Hz Three-phase	功率 [Kw]	长度Lt [mm]
VL 3/4	-	0.55	464
VL 3/5	-	0.75	488
VL 3/6	-	0.75	512
VL 3/7	-	1.1	536
VL 3/8	VL 3/8T	1.1	460
VL 3/9	VL 3/9T	1.5	634
VL 3/10	VL 3/10T	1.5	658

STAMPING SS SUBMERSIBLE PUMP

VL SERIES / 冲压不锈钢潜水泵 VL系列

PERFORMANCE CURVE CHART 性能曲线图

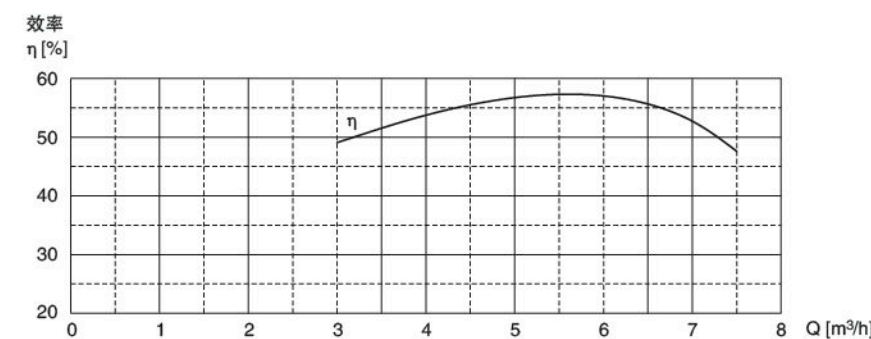
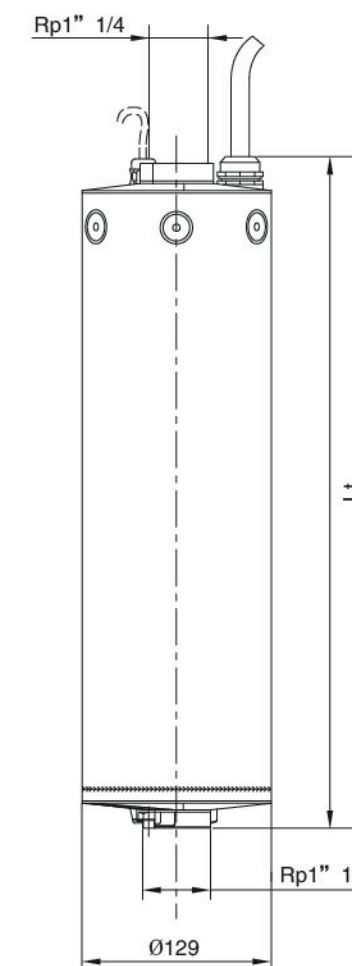
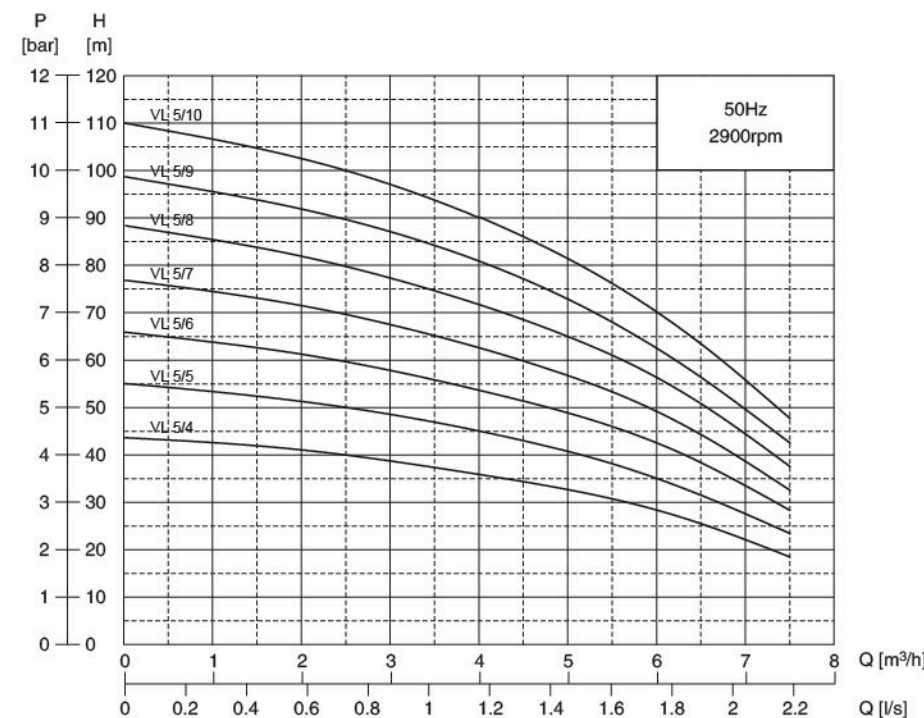

单相220V-240V/50Hz Single-phase	三相380V-415V/50Hz Three-phase	功率 [Kw]	长度Lt [mm]
VL 5/4	-	0.75	464
VL 5/5	-	1.1	488
VL 5/6	VL 5/6T	1.1	512
VL 5/7	VL 5/7T	1.5	586
VL 5/8	VL 5/8T	1.5	610
VL 5/9	VL 5/9T	2.2	634
VL 5/10	VL 5/10T	2.2	658

- VS
- VS 1
- VS 2
- VS 3
- VS 5
- VS 8
- VS 13
- VS 17
- VS 30
- VS 45
- VS 60
- VS 75
- VS 95
- VS 125
- VS 160
- VS 210
- VN
- VN 3
- VN 5
- VN 9
- VL
- VL 3
- VL 5
- VL 9
- OTHERS

STAMPING SS SUBMERSIBLE PUMP

VL SERIES / 冲压不锈钢潜水泵 VL系列

PERFORMANCE CURVE CHART 性能曲线图

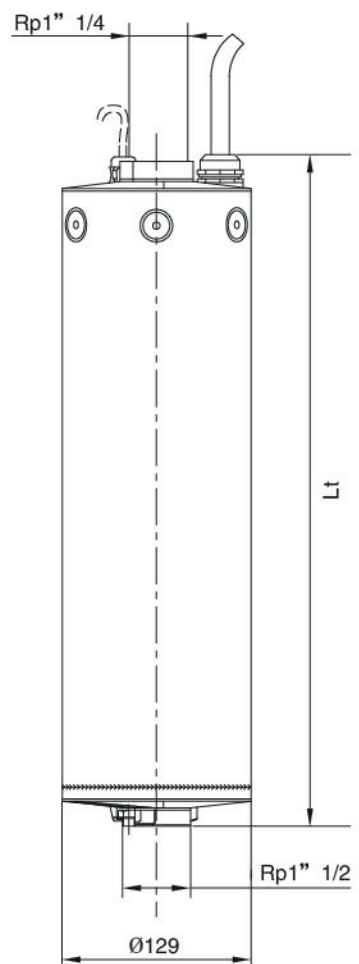
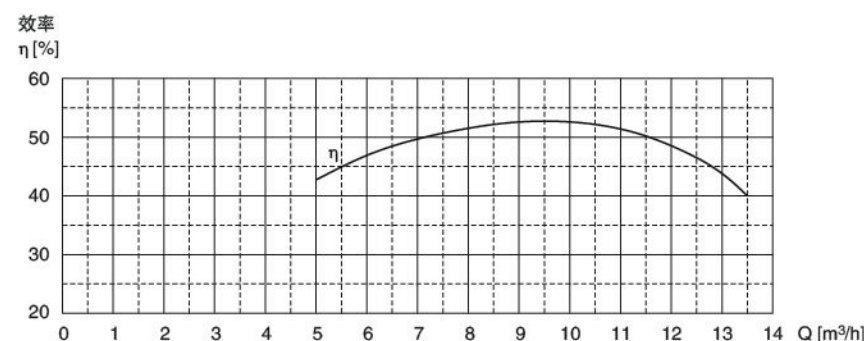
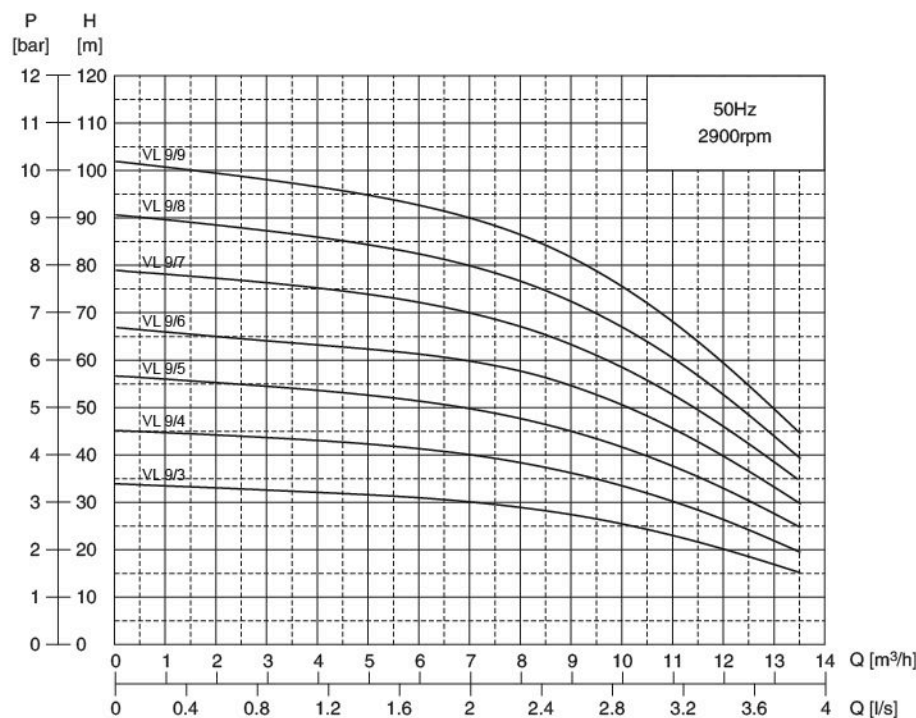

单相220V-240V/50Hz Single-phase	三相380V-415V/50Hz Three-phase	功率 [Kw]	长度Lt [mm]
VL 9/3	-	1.1	488
VL 9/4	VL 9/4T	1.5	568
VL 9/5	VL 9/5T	2.2	598
VL 9/6	VL 9/6T	2.2	628
-	VL 9/7T	3	658
-	VL 9/8T	3	688
-	VL 9/9T	3	718

STAMPING SS SUBMERSIBLE PUMP

VS VN VL / 冲压不锈钢潜水泵 VS VN VL

TECHNOLOGY INDEX 技术索引

UNIT CONVERSION TABLES 单位换算表

Power 功率			
Unit 单位	Horsepower 马力	Watt 瓦特	BTU 英制热量单位
1	1.0000	745.7000	42.4300
2	0.0013	1.0000	0.0569
3	0.0236	17.5800	1.0000

Flow Conversion 流量转换						
Unit 单位	U.S. gallon/min 美制加仑/分	UK gallon/min 英制加仑/分	acre inch/h 英亩 英寸/时	L/sec 升/秒	L/min 升/分	m³/h 立方米/时
1	1.0000	0.8330	0.0022	0.0631	3.7850	0.2270
2	1.2000	1.0000	0.0026	0.0757	4.5460	0.2720
3	452.4000	376.9000	1.0000	28.5700	1715.2700	102.7700
4	15.8500	13.2000	0.0350	1.0000	60.0000	3.6000
5	0.2642	0.2200	0.0006	0.0167	1.0000	0.0600
6	4.4000	3.6900	0.0097	0.2778	16667.0000	1.0000

Volume conversion 体积转换							
Unit 单位	cubic inch 立方英寸	gallon 加仑	cubic foot 立方英尺	cubic yard 立方码	acre foot 英亩 英尺	liter 升	cubic meter 立方米
1	1.00	0.00	0.00	2.14E-05	1.33E-08	0.02	1.64E-05
2	231.00	1.00	0.13	0.00	3.07E-06	3.79	0.0038
3	1728.00	74805.00	1.00	0.04	0.00	28.32	0.0283
4	46656.00	202.00	27.00	1.00	0.00	764.60	0.7646
5	75270000.0	325892.0	43592.0	1613.0	1.0	1233000.0	1233.0000
6	61.020	0.264	0.035	0.001	8.11E-07	1.000	0.0010
7	61023.000	264.200	35.310	1.308	0.001	1000.000	1.0000

Length Conversion 长度转换								
Unit 单位	inch 英寸	foot 英尺	yard 码	mile 英里	mm 毫米	cm 厘米	m 米	km 千米
1	1.0	0.1	0.0	1.58E-05	25.4	2.5	0.0	2.54E05
2	12.0	1.0	0.3	0.0	304.8	30.5	0.3	0.00031
3	36.0	3.0	1.0	0.0	914.4	91.4	0.9	0.00091
4	6336.0	5280.0	1760.0	1.0	16093444.0	160934.4	1609.3	1.60940
5	0.0	0.0	0.0	6.21E-07	1.0	0.1	0.0	0.00001
6	0.4	0.0	0.0	6121E-06	10.0	1.0	0.0	0.00001
7	39.4	3.3	1.1	0.0	100.0	100.0	1.0	0.00100
8	39370.0	3280.8	1093.6	0.6	1000000.0	100000.0	-	1.00000

Pressure Conversion 压力转换						
Unit 单位	- 磅/平方英尺	foot 英尺	m 米	Kg/cm³ 千克/立方厘米	Kpa 千帕	bar 巴
1	1.000	2.310	0.0703	0.070	6.895	0.069
2	0.434	1.000	0.305	0.031	2.984	0.030
3	1.422	3.281	1.000	0.100	9.804	0.098
4	14.220	32.810	10.000	1.000	98.040	0.980
5	0.145	0.335	0.102	0.010	1.000	1.010
6	14.500	33.520	10.200	1.020	100.000	1.000

华氏度 Fahrenheit degree 32.0 212.0 F=C9/5+32
 摄氏度 Celsius degree 0.0 100.0 C= (F-32) 5/9

- VS
- VS 1
- VS 2
- VS 3
- VS 5
- VS 8
- VS 13
- VS 17
- VS 30
- VS 45
- VS 60
- VS 75
- VS 95
- VS 125
- VS 160
- VS 210
- VN
- VN 3
- VN 5
- VN 9
- VL
- VL 3
- VL 5
- VL 9
- OTHERS

STAMPING SS SUBMERSIBLE PUMP

VS VN VL / 冲压不锈钢潜水泵
VS VN VL

The matched cable specification table 潜水电机配套电缆规格表

Motor Rating		KW	HP	1.5	2.5	4	6	10	16	25	35	50	70	95	120	150	185	240	300	400	
220V 50HZ		0.37	1/2	300	510	820	1230	2010	3160	4810	6540	8890									
		0.55	3/4	200	350	550	830	1370	2150	3280	4460	6060	8060								
33-lead		0.75	1	160	270	430	650	1070	1680	2550	3470	4710	6250	7970	9510						
		1.1	1 1/2	110	290	300	450	750	1170	1790	2430	3310	4400	5620	6700	7790	8970				
(230v may use 110% of table)		1.5	2	80	140	230	340	570	900	1380	1880	2570	3430	4410	5290	6180	7150	8470	9670		
		2.2	3	50	90	150	230	380	600	950	1270	1740	2330	3000	3610	4230	4910	5840	6700	7790	
(240V may use 119% of table)		3	4	40	70	110	150	280	440	670	920	1270	1700	2180	2630	3080	3570	4240	4850	5630	
		3.7	5	30	50	80	110	220	360	550	750	1030	1390	1790	2150	2520	2930	3480	4000	4640	
		4	5 1/2	30	50	60	90	200	320	490	670	920	1240	1590	1910	2240	2590	3070	3520	4070	
		5.5	7 1/2	0	30	40	80	150	240	380	520	710	960	1240	1490	1750	2040	2430	2790	3250	
		7.5	10	0	0	0	60	110	170	270	370	500	680	870	1050	1230	1420	1690	1930	2230	
		11	15	0	0	0	40	80	120	190	270	370	500	650	790	930	1080	1290	1490	1740	
		15	20	0	0	0	0	60	90	150	200	280	380	500	610	720	840	1010	1170	1370	
		18.5	25	0	0	0	0	0	70	110	160	220	300	390	480	570	660	800	920	1090	
		22	30	0	0	0	0	0	60	100	130	190	260	330	400	480	560	670	780	910	
		0.37	1/2	930	1550	2460	3670	6030	9460												
		0.55	3/4	630	1050	1670	2500	4100	5860	9790											
		0.75	1	490	820	1300	1950	3200	4330	7620											
		1.1	1 1/2	340	570	910	1360	2240	3200	5350	7280	9890									
		1.5	2	260	430	700	1040	1720	2340	4120	5630	7690									
380V 50HZ		2.2	3	170	290	460	700	1150	1600	2770	3790	5190	6950	8950							
		3	4	120	210	340	510	840	1230	2030	2770	3790	5070	6530	7840	9190					
33-lead		3.7	5	100	170	270	410	680	980	1650	2260	3090	4140	5340	6420	7540	7850				
		4	5 1/2	90	150	250	370	610	920	1480	2020	2770	3700	4750	5710	6680	7740	9180			
(230v may use 110% of table)		5.5	7 1/2	70	110	190	280	470	690	1140	1560	2140	2870	3700	4460	5240	6090	7250	8330	9700	
		7.5	10	50	80	130	200	330	530	810	1110	1510	2030	2610	3130	3670	4250	5040	5770	6680	
(415V may use 119% of table)		11	15	0	60	90	140	240	360	590	810	1160	1510	1950	2350	2770	3230	3860	4450	5200	
		15	20	0	0	70	110	180	270	450	620	910	1160	1500	1820	2150	2520	3020	3490	4110	
		18.5	25	0	0	0	80	140	210	350	490	770	910	1190	1440	1700	1990	2390	2770	3260	
		22	30	0	0	0	0	120	180	300	410	570	770	1000	1210	1440	1680	2010	2330	2740	
		30	40	0	0	0	0	0	130	220	310	420	570	740	900	1060	1230	1470	1700	1990	
		37	50	0	0	0	0	0	110	180	240	340	460	590	710	840	980	1170	1350	1580	
		45	60	0	0	0	0	0	0	150	200	280	380	490	600	700	820	980	1130	1330	
		55	75	0	0	0	0	0	0	120	170	240	330	420	510	610	710	860	990	1170	
		75	100	0	0	0	0	0	0	0	0	180	240	320	390	460	530	640	740	880	
		90	125	0	0	0	0	0	0	0	0	0	190	240	290	350	400	480	550	650	
		110	150	0	0	0	0	0	0	0	0	0	0	210	250	290	340	410	470	550	
		130	175	0	0	0	0	0	0	0	0	0	0	180	220	260	300	360	420	500	
		150	200	0	0	0	0	0	0	0	0	0	0	190	230	270	320	370	440		



U-FLO-RELIABLE BRAND!
U-flo-可信赖的品牌!

