



More information on the website  
[radwag.com/en/info,w1,QM0](http://radwag.com/en/info,w1,QM0)

# AS 160.R2 PLUS Analytical Balance



The drawings, photos and graphics used are for illustrative purposes only.

## Functions



Autotest



Dosing



Percent Weighing



Totalizing



Parts counting



Peak hold



Newton unit measurement



Statistics



Checkweighing



Under-pan weighing



GLP Procedures



Animal weighing



Density determination

## Datasheet

Metrological parameters	
Maximum capacity [Max]	160 g
Minimum load	10 mg
Readability [d]	0,1 mg
Verification unit [e]	1 mg
Tare range	-160 g
Standard repeatability [5% Max]	0,07 mg

<b>Metrological parameters</b>	
Standard repeatability [Max]	0,08 mg
Standard minimum weight (USP)	140 mg
Standard minimum weight (U=1%, k=2)	14 mg
Permissible repeatability [5% Max]	0,09 mg
Permissible repeatability [Max]	0,1 mg
Linearity	±0,2 mg
Stabilization time	2 s
Adjustment	internal (automatic)
OIML Class	I
<b>Physical parameters</b>	
Leveling system	manual
Display	LCD (backlit)
Protection class	IP 43
Delivery components	Balance, weighing pan, weighing pan shield, centring ring, bottom cover, power supply.
Weighing pan dimensions	ø100 mm
Packaging dimensions	545×455×575 mm
Net weight	7 kg
Gross weight	9 kg
<b>Communication interface</b>	
Communication interface	2×RS232 <sup>1</sup> , 2×USB-A (interchangeable), USB-B, Wi-Fi (option)
<b>Electrical parameters</b>	
Power supply	Adapter: 100 – 240V AC 50/60Hz 0,6A; 12V DC 1,2A Balance: 12 – 15V DC 0,4A max
Power consumption max.	3 W
Overvoltage protection	YES
<b>Environmental conditions</b>	
Operating temperature	+10 ÷ +40 °C
Relative humidity	40% ÷ 80%

Repeatability is expressed as a standard deviation from 10 weighing cycles. Stabilization time depends on the ambient conditions and the dynamics of weighing pan loading; specified for FAST profile. 1 Barcode scanners, available as weighing instrument accessory, communicate with the instrument via RS232 interface exclusively.

\* Wi-Fi® is a registered trademark of Wi-Fi® Alliance.



Extra payment for verification



## Accessories

Holders for laboratory flasks  
 Power Adapters  
 Barcode scanners  
 Cigarette lighter receptacle power supply cables  
 Density determination KIT  
 USB cable (scale - printer)  
 Professional weighing table

Displays  
 Protective cover for balances  
 Weighing dishes  
 Antistatic ionizer  
 Receipt Printer  
 THBR 2.0 System - Ambient Conditions Monitoring  
 RS 232, RS 485 cables

Holders for test tubes and filters  
Workstation for Pipettes Calibration  
Antivibration Tables

Under-pan weighing  
RS 232 cables (scale - printer)

## Software

RAD-KEY  
R Panel  
R-LAB  
E2R System

LabVIEW Driver  
Alibi Reader  
RADWAG Development Studio  
R.Barcode

## Device dimensions

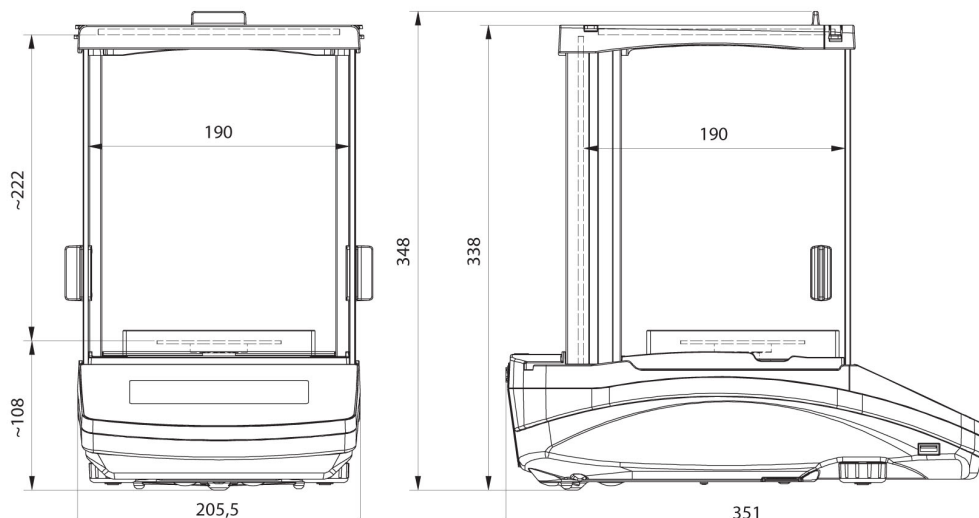

AS R2, d = 0.01 mg

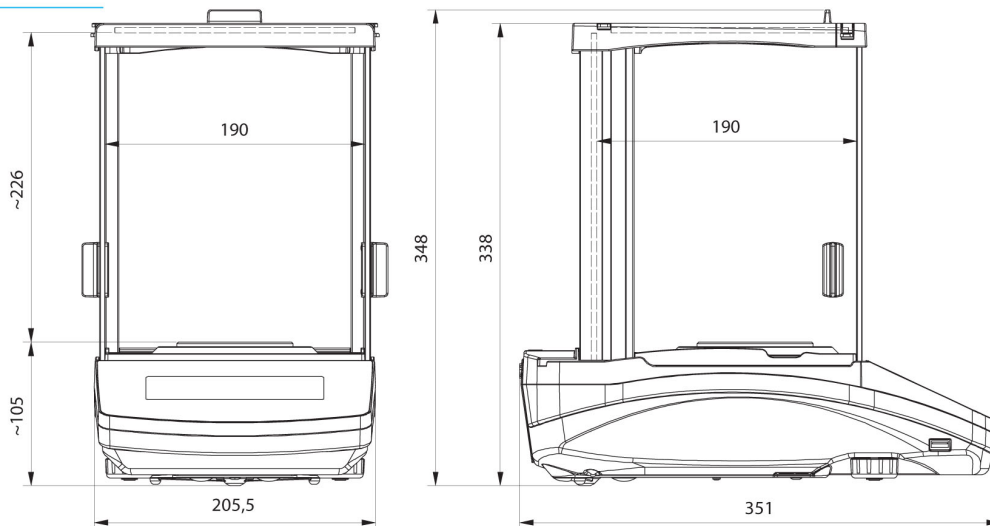

AS R2, AS R1 d = 0.1 mg