



Pressure transmitter

Huba Control

OEM relative and absolute pressure transmitter

Type 511

Type 511 pressure transmitters meet the highest specifications for longevity, accuracy, temperature stability and EMC characteristics, making them suitable for an extremely wide range of demanding industrial applications.



Pressure range

-1 ... 0 – 600 bar

- + Compact, rugged construction for highest operational reliability
- + No media egress when exceeding rupture pressure
- + Negligible temperature influence on accuracy
- + Excellent EMC capacity
- + Saving time by quick cable mounting by the customer with swift connector

Technical overview

Pressure range

Relative	-1 ... 0 – 600 bar
Absolute	0 ... 25 bar

Operating conditions

Medium		Liquids and gases	
Temperature	Ambient ¹⁾	FPM	-15 ... +125 °C
		EPDM	-40 ... +150 °C (UL max. 125 °C)
		NBR	-25 ... +125 °C
		ratiom. output, AMP JPT	max. +125 °C
Tolerable overload / Rupture pressure ²⁾		all other versions	max. +85 °C
		< 6	3.0 x fs
		≥ 6	2.5 x fs (max. 900 bar)

Materials

Case		Stainless steel 1.4305 / AISI 303
Materials in contact with the medium	Pressure connection	Stainless steel 1.4305 / AISI 303
	Sensor	Ceramic Al ₂ O ₃ (96%)
	Media stop system	PPS
	Sealing material	FPM, EPDM, NBR, FPM spec.

Media stop system

Media stop system to prevent media egress when exceeding rupture pressure range (> 40 bar nominal value).

Electrical overview

	Output	Power supply	Load	Current consumption ⁴⁾
2 wire	4 ... 20 mA	8.0 ... 33 VDC	< 400 Ω / < 10 nF	< 20 mA
	0 ... 5 V	8.0 ... 33 VDC	> 10 kΩ / > 100 nF	< 4 mA
	1 ... 6 V	8.0 ... 33 VDC	> 10 kΩ / < 100 nF	< 4 mA
3 wire	0 ... 10 V	11.4 ... 33 VDC	> 10 kΩ / < 100 nF	< 4 mA
	0 ... 10 V	24 VAC ±15%	> 10 kΩ / < 100 nF	< 4 mA
	ratiom. 10 ... 90%	5 VDC ±5%	> 10 kΩ / < 100 nF	< 4 mA
Polarity reversal protection	Short circuit proof and protected against polarity reversal. Each connection is protected against crossover up to max. supply voltage.			
Insulation voltage			standard	500 VDC
			optional	1000 VDC

Dynamic response

Response time	< 2 ms, typ. 1 ms
Load cycle	< 100 Hz

Protection standard

With connector DIN EN 175301-803-C	IP 65
All other versions	IP 67

Electrical connection

Cable 1.5 m
Swift connector
Connector AMP (Junior power time)
Connector M12x1 plastic thread
Connector M12x1 metal thread
Connector DIN EN 175301-803-C (industrial standard 9.4 mm)

Pressure connection

Inside thread	G 1/4 with O-Ring seal
	G 1/4 sealed at back, DIN EN ISO 1179-2
	G 1/2 sealed at front
	G 1/2 sealed at back and manometer (combi)
Outside thread	1/4 -18 NPT
	R 1/4 EN 10226
	M12x1.5 sealed at back, DIN EN ISO 1179-2
	M14x1.5 sealed at back, DIN EN ISO 1179-2

Installation arrangement

Unrestricted

Tests / Admissions

Electromagnetic compatibility	CE conformity acc. EN 61326-2-3
UL	acc. Standard 61010-1
Shock acc. IEC 60068-2-27	100 g, 11 ms half sine wave, all 6 directions. Free fall from 2 m on concrete (6x)
Constant shock acc. IEC 60068-2-29	40 g for 6 ms, 1000x all 3 directions
Vibration acc. IEC 60068-2-6	20 g, 2 ... 2000 Hz with amplitude ± 15 mm, 1 Octave/min. all 3 directions, 50 constant load

Weight

Version with inside thread	~ 85 g
Version with outside thread	~ 95 g

Packaging (Please state on order)

Single packaging in cardboard	accessories integrated
Multiple packaging in cardboard (25 pcs)	accessories integrated

¹⁾ Version until +150 °C on request

²⁾ higher overload and rupture pressure on request

³⁾ at nominal pressure

Accuracy

Parameter		Unit	
Tolerance zero point	max.	% fs	± 0.3
Tolerance full scale	max.	% fs	± 0.3
Resolution		% fs	0.1
Total of linearity, hysteresis and repeatability	max.	% fs	± 0.3
Long term stability acc. DIN EN 60770		% fs	± 1.0
TC zero point ¹⁾	max.	% fs/10K	± 0.15
TC sensitivity ¹⁾	typ.	% fs/10K	± 0.15

Test conditions: 25 °C, 45% RH, power supply 24 VDC
TC z.p. / TC s. -40 ... +125 °C

Order code selection table in bar

		1	2	3	4	5	6	7	8	9	10	
		511.	X	X	X	X	X	X	X	X	X	
Pressure mode	Relative		9									
	Absolute		8									
Pressure range ²⁾	-1 ... 0 bar		9	0	0							
	0 ... 1 bar			1	1							
	0 ... 1.6 bar			1	2							
	0 ... 2.5 bar			1	4							
	0 ... 4 bar			1	5							
	0 ... 6 bar			1	7							
	0 ... 10 bar			3	0							
	0 ... 16 bar			3	1							
	0 ... 25 bar			3	2							
	0 ... 40 bar		9	3	3						2	
	0 ... 60 bar		9	4	0						2	
	0 ... 100 bar		9	4	1						2,5	
	0 ... 160 bar		9	4	2						2,5	
	0 ... 250 bar		9	4	3						2,5	
	0 ... 400 bar (FPM seal only -40 ... +150 °C)		9	5	4	6					2,5	
	0 ... 600 bar (FPM seal only -40 ... +150 °C)		9	5	5	6					2,5	
▲ Full scale signal at these pressures												
Sealing material ³⁾	FPM Fluoro elastomer	-15 ... +125 °C				0						
	EPDM Ethylene propylene	-40 ... +150 °C (UL max. 125 °C)				6						
	NBR Butadiene Acrylonitrile					1						
Adjustment	Factory					0						
	0 ... 5 V	8.0 ... 33 VDC IN=1 / OUT=3 / GND=4					1					
Output / power supply	0 ... 5 V	8.0 ... 33 VDC IN=1 / OUT=4 / GND=3					F	5,7				
	1 ... 6 V	8.0 ... 33 VDC IN=1 / OUT=3 / GND=4					6					
	0 ... 10 V	8.0 ... 33 VDC IN=1 / OUT=4 / GND=3					G	5,7				
	0 ... 10 V	11.4 ... 33 VDC IN=1 / OUT=3 / GND=4					2					
	0 ... 10 V	11.4 ... 33 VDC IN=1 / OUT=4 / GND=3					H	5,7				
	0 ... 10 V	24 VAC ±15%					7	1,0				
4 ... 20 mA	8.0 ... 33 VDC					3						
ration. 10 ... 90%	5 VDC ±5%					4						
Electrical connection	Cable 1.5 m								0			
	Swift connector								1			
	Connector	AMP OPT ⁴⁾								2		
		M12x1 plastic thread ⁴⁾								5		
		M12x1 metal thread ⁴⁾								7		
		DIN EN 175301-803-C	2w:IN=3/OUT=1 3w:IN=3/OUT=2/GND=1							8		
		DIN EN 175301-803-C	2w:IN=1/OUT=2 3w:IN=1/OUT=3/GND=2							9		
	Pressure connection ⁵⁾	Inside thread	G ¼ with O-Ring seal (no pressure tip orifice possible)								1	1,2
			G ¼ sealed at back, DIN EN ISO 1179-2								4	
G ½ sealed at front											9	
Outside thread		G ½ sealed at back and manometer (combi)									8	
		¼ -18 NPT									3	
		R ¼, EN 10226									7	
M12x1.5 sealed at back, DIN EN ISO 1179-2										5		
	M14x1.5 sealed at back, DIN EN ISO 1179-2									6		
Version	Stainless steel without media stopper (≤ 60 bar)										1	
	Stainless steel with media stopper (standard ≥ 40 bar)										2	
	Stainless steel with pressure tip orifice (≥ 100 bar)										5	
Pressure range variation (optional)	Indicate W and state range on order (e.g.: W0... + 8bar/OUT1...6V)										W	

Accessories (supplied loose)

	Order Number
Female connector for connector M12x1	106975
Female connector AMP (Junior power timer) 2-wire	110442
Female connector AMP (Junior power timer) 3-wire	108767
Female connector swift connector (included in delivery)	117312
Female connector	104244
Calibration certificate	104551

¹⁾ TC = Temperature coefficient

²⁾ Other pressure range on request

³⁾ Other sealing material on request

⁴⁾ Delivery without female connector

⁵⁾ Other pressure connection on request

Order code selection table in psi			1	2	3	4	5	6	7	8	9	10	
			511.	X	X	X	X	X	X	X	X	X	
Pressure mode	Relative		9										
	Absolute		8										
Pressure range ¹⁾	-30 ... 0"hg		9	A	0								
	0 ... 15 psi			B	1								
	0 ... 30 psi			B	4								
	0 ... 60 psi			B	5								
	0 ... 100 psi			B	7								
	0 ... 200 psi			C	1								
	0 ... 300 psi			C	2								
	0 ... 500 psi		9	C	3							2	
	0 ... 750 psi		9	D	0							2	
	0 ... 1000 psi		9	D	1							2,5	
	0 ... 2000 psi		9	D	2							2,5	
	0 ... 3000 psi		9	D	3							2,5	
	0 ... 5000 psi (FPM seal only -40 ... +150 °C)		9	E	4	6						2,5	
	0 ... 7500 psi (FPM seal only -40 ... +150 °C) ▲ Full scale signal at these pressures		9	E	5	6						2,5	
Sealing material ²⁾	FPM	Fluoro elastomer						0					
								6					
	EPDM	Ethylene propylene						1					
	NBR	Butadiene Acrylonitrile						2					
Adjustment	Factory						0						
Output / power supply	0 ... 5 V	8.0 ... 33 VDC IN=1 / OUT=3 / GND=4							1				
		8.0 ... 33 VDC IN=1 / OUT=4 / GND=3							F	5,7			
	1 ... 6 V	8.0 ... 33 VDC IN=1 / OUT=3 / GND=4							6				
		8.0 ... 33 VDC IN=1 / OUT=4 / GND=3							G	5,7			
	0 ... 10 V	11.4 ... 33 VDC IN=1 / OUT=3 / GND=4							2				
		11.4 ... 33 VDC IN=1 / OUT=4 / GND=3							H	5,7			
	4 ... 20 mA	8.0 ... 33 VDC						7	1,0				
	ratiom. 10 ... 90%	5 VDC ±5%						3					
								4					
Electrical connection	Cable 1.5 m										0		
	Swift connector										1		
	Connector	AMP JPT ³⁾										2	
		M12x1 plastic thread ³⁾										5	
		M12x1 metal thread ³⁾										7	
		DIN EN 175301-803-C	2w: IN=3 / OUT=1 3w: IN=3 / OUT=2 / GND=1									8	
DIN EN 175301-803-C	2w: IN=1 / OUT=2 3w: IN=1 / OUT=3 / GND=2									9			
Pressure connection ⁴⁾	Inside thread	G ¼ mit O-Ring seal (no pressure tip orifice possible)									1	1,2	
		G ¼ sealed at back, DIN EN ISO 1179-2									4		
		G ½ sealed at front									9		
		G ½ sealed at back and manometer (combi)									8		
	Outside thread	¼ -18 NPT									3		
		R ¼, EN 10226									7		
		M12x1.5 sealed at back, DIN EN ISO 1179-2									5		
		M14x1.5 sealed at back, DIN EN ISO 1179-2									6		
Version	Stainless steel without media stopper (< 700 psi)										1		
	Stainless steel with media stopper (standard ≥ 500 psi)										2		
	Stainless steel with pressure tip orifice (≥ 1000 psi)										5		
Pressure range variation (optional)	Indicate W and state range on order (e.g.: W0... + 120psi/OUT1...6V)											W	

¹⁾ Other pressure range on request

²⁾ Other sealing material on request

³⁾ Delivery without female connector

⁴⁾ Other pressure connection on request

				1	2	3	4	5	6	7	8	9	10	
Order code selection table in MPa				511.	X	X	X	X	X	X	X	X	X	
Pressure mode	Relative			9										
	Absolute			8										
Pressure range ¹⁾	-0.1 ... 0 MPa			9	F	0								
	0 ... 0.1 MPa				G	1								
	0 ... 0.16 MPa				G	2								
	0 ... 0.25 MPa				G	4								
	0 ... 0.4 MPa				G	5								
	0 ... 0.6 MPa				G	7								
	0 ... 1 MPa				H	0								
	0 ... 1.6 MPa				H	1								
	0 ... 2.5 MPa				H	2								
	0 ... 4 MPa			9	H	3							2	
	0 ... 6 MPa			9	K	0							2	
	0 ... 10 MPa			9	K	1							2,5	
	0 ... 16 MPa			9	K	2							2,5	
	0 ... 25 MPa			9	K	3							2,5	
	0 ... 40 MPa (FPM seal only -40 ... +150 °C)			9	L	4	6						2,5	
	0 ... 60 MPa (FPM seal only -40 ... +150 °C)			9	L	5	6						2,5	
	▲ Full scale signal at these pressures													
Sealing material ²⁾	FPM	Fluoro elastomer	-15 ... +125 °C			0								
			-40 ... +150 °C (UL max. 125 °C)			6								
	EPDM	Ethylene propylene				1								
	NBR	Butadiene Acrylonitrile				2								
Adjustment	Factory						0							
Output / power supply	0 ... 5 V	8.0 ... 33 VDC	IN=1 / OUT=3 / GND=4							1				
		8.0 ... 33 VDC	IN=1 / OUT=4 / GND=3							F	5,7			
	1 ... 6 V	8.0 ... 33 VDC	IN=1 / OUT=3 / GND=4								6			
		8.0 ... 33 VDC	IN=1 / OUT=4 / GND=3								G	5,7		
	0 ... 10 V	11.4 ... 33 VDC	IN=1 / OUT=3 / GND=4								2			
		11.4 ... 33 VDC	IN=1 / OUT=4 / GND=3								H	5,7		
		24 VAC ±15%									7	1,0		
4 ... 20 mA	8.0 ... 33 VDC									3				
ratio: 10 ... 90%	5 VDC ±5%									4				
Electrical connection	Cable 1.5 m											0		
	Swift connector											1		
	Connector	AMP JPT ³⁾										2		
		M12x1 plastic thread										5		
		M12x1 metal thread ³⁾										7		
		DIN EN 175301-803-C	2w:IN=3/OUT=1 3w:IN=3/OUT=2/GND=1									8		
DIN EN 175301-803-C		2w:IN=1/OUT=2 3w:IN=1/OUT=3/GND=2									9			
Pressure connection ⁴⁾	Inside thread	G ¼ with O-Ring seal (no pressure tap orifice possible)										1	1,2	
		G ¼ sealed at back, DIN EN ISO 1179-2											4	
	G ½ sealed at front											9		
	G ½ sealed at back and manometer (combi)											8		
	Outside thread	¼ -18 NPT											3	
		R ¼, EN 10226											7	
		M12x1.5 sealed at back, DIN EN ISO 1179-2											5	
M14x1.5 sealed at back, DIN EN ISO 1179-2											6			
Version	Stainless steel without media stopper (≤ 6 MPa)												1	
	Stainless steel with media stopper (standard ≥ 4 MPa)												2	
	Stainless steel with pressure tap orifice (≥ 10 MPa)												5	
Pressure range variation (optional)	Indicate W and state range on order (e.g.: W0... + 0.8MPa/OUT1...6V)											W		

¹⁾ Other pressure range on request

²⁾ Other sealing material on request

³⁾ Delivery without female connector

⁴⁾ Other pressure connection on request

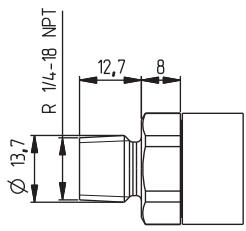

G 1/4
Inside thread

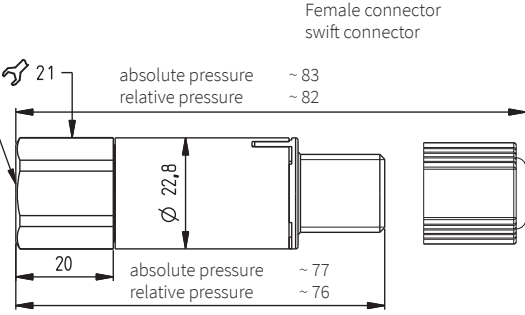

Female connector
swift connector

2 wire
(4 ... 20 mA)

3 wire

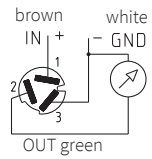
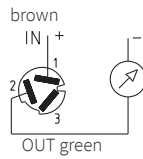

All absolute versions
are especially marked
with an indentation.

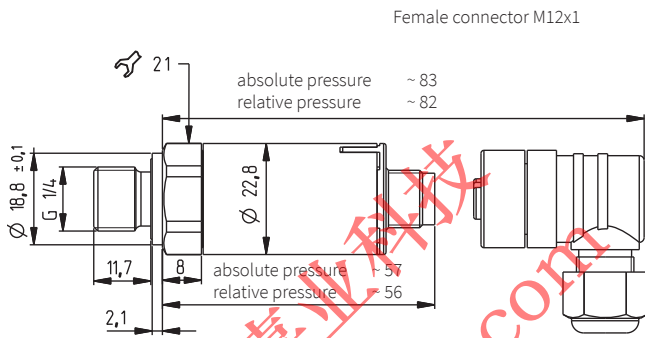
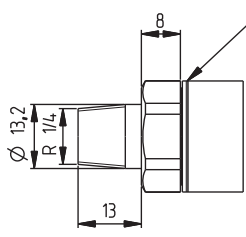

Female connector M12x1

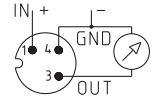
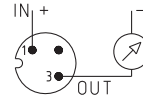

Female connector AMP JPT

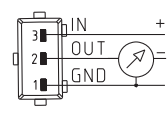
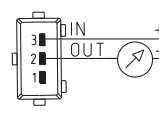
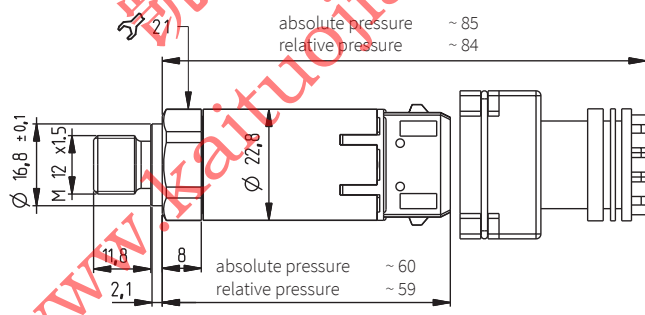
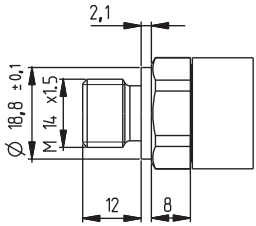

Female connector
DIN EN 175301-803-C

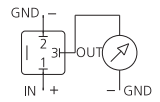
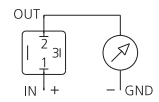
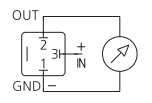
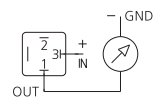
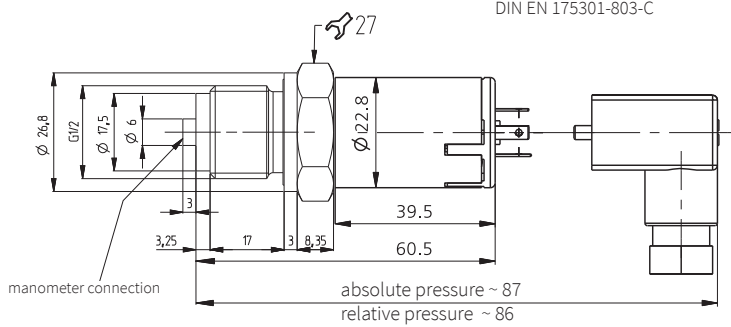
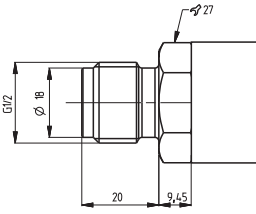

Huba Control AG

Headquarters Schweiz
Industriestrasse 17
CH-5436 Würenlos
Telefon +41 56 436 82 00
Fax +41 56 436 82 82
info.ch@hubacontrol.com

Huba Control AG

Vestiging Nederland
Hamseweg 20A
NL-3828 AD-Hoogland
Telefoon +31 33 433 03 66
Telefax +31 33 433 03 77
info.nl@hubacontrol.com

Huba Control AG

Niederlassung Deutschland
Schlattgrabenstrasse 24
D-72141 Walddorfhäslach
Telefon +49 7127 2393 00
Fax +49 7127 2393 20
info.de@hubacontrol.com

Huba Control USA, Inc.

Office United States of America
303 Wyman Street
Suite #300
Waltham MA 02451
Tel: +1 866-6HUBACO (+1 866-648-2226)
info.usa@hubacontrol.com

Huba Control SA

Succursale France
Rue Lavoisier
Technopôle Forbach-Sud
F-57602 Forbach Cedex
Téléphone +33 3 87 84 73 00
Télécopieur +33 3 87 84 73 01
info.fr@hubacontrol.com

Huba Control AG

Branch Office United Kingdom
Unit 13 Berkshire House, County Park Business
Centre, Shrivenham Road
Swindon Wiltshire SN1 2NR
Phone +44 1993 77 66 67
Fax +44 1993 77 66 71
info.uk@hubacontrol.com

www.hubacontrol.com

