



More information on the website  
[radwag.com/en/info,w1,LZY](http://radwag.com/en/info,w1,LZY)

# AS 220.R1 PLUS Analytical Balance



The drawings, photos and graphics used are for illustrative purposes only.

## Functions

-  Autotest
-  Dosing
-  Percent Weighing
-  Totalizing
-  Parts counting
-  Peak hold
-  Newton unit measurement
-  Statistics
-  Checkweighing
-  Under-pan weighing
-  GLP Procedures
-  Animal weighing
-  Density determination

## Datasheet

Metrological parameters	
Maximum capacity [Max]	220 g
Minimum load	10 mg
Readability [d]	0,1 mg
Tare range	-220 g
Standard repeatability [5% Max]	0,07 mg
Standard repeatability [Max]	0,08 mg

<b>Metrological parameters</b>	
Standard minimum weight (USP)	140 mg
Standard minimum weight (U=1%, k=2)	14 mg
Permissible repeatability [5% Max]	0,09 mg
Permissible repeatability [Max]	0,1 mg
Linearity	±0,2 mg
Stabilization time	2 s
Adjustment	external
OIML Class	-

<b>Physical parameters</b>	
Leveling system	manual
Display	LCD (backlit)
Protection class	IP 43
Delivery components	Balance, weighing pan, weighing pan shield, bottom cover, power supply.
Weighing pan dimensions	ø100 mm
Packaging dimensions	490×400×520 mm
Net weight	7,3 kg
Gross weight	9,3 kg

<b>Communication interface</b>	
Communication interface	2×RS232, 2×USB-A (interchangeable), USB-B, Wi-Fi (option)

<b>Electrical parameters</b>	
Power supply	Adapter: 100 – 240V AC 50/60Hz 0,6A; 12V DC 1,2A Balance: 12 – 15V DC 0,4A max

<b>Environmental conditions</b>	
Operating temperature	+10 ÷ +40 °C
Relative humidity	40% ÷ 80%

Repeatability is expressed as a standard deviation from 10 weighing cycles. Stabilization time depends on the ambient conditions and the dynamics of weighing pan loading; specified for FAST profile.

\* Wi-Fi® is a registered trademark of Wi-Fi® Alliance.



## Accessories

Holders for laboratory flasks  
 Power Adapters  
 Barcode scanners  
 Cigarette lighter receptacle power supply cables  
 Density determination KIT  
 USB cable (scale - printer)  
 Professional weighing table  
 Holders for test tubes and filters  
 Workstation for Pipettes Calibration  
 Antivibration Tables

Displays  
 Weighing dishes  
 Antistatic ionizer  
 Receipt Printer  
 AP2-1 Current Loop Unit  
 THBR 2.0 System - Ambient Conditions Monitoring  
 RS 232, RS 485 cables  
 Under-pan weighing  
 RS 232 cables (scale - printer)

# Software

RAD-KEY  
R Panel  
R-LAB  
E2R System

LabVIEW Driver  
Alibi Reader  
RADWAG Development Studio  
R.Barcode

# Device dimensions

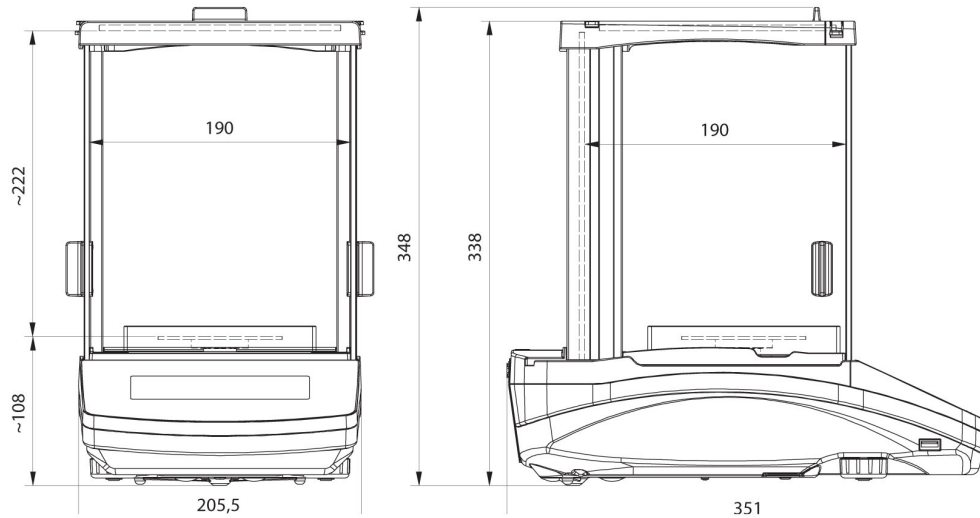

AS R2, d = 0.01 mg

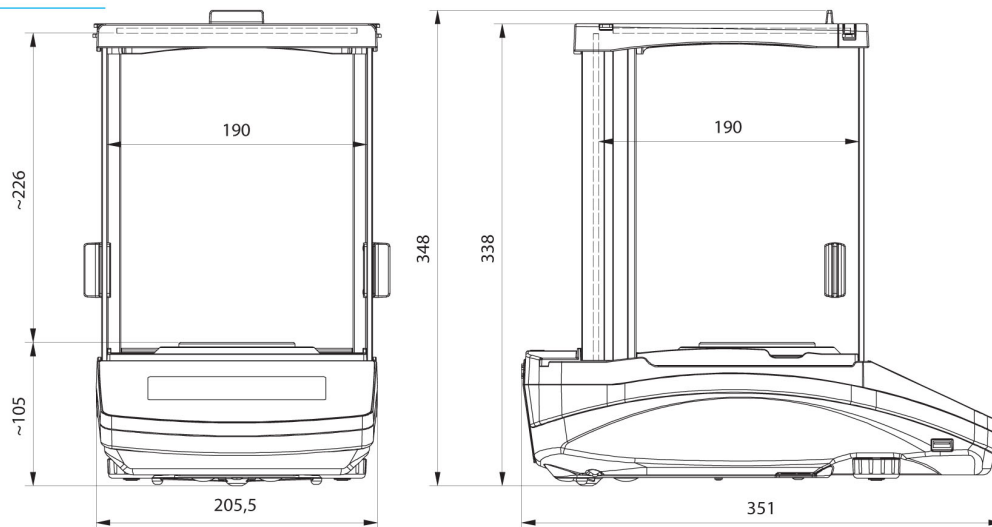

AS R2, AS R1 d = 0.1 mg