

Laboratory Mixers L5 Series

Capacity

1ml up to 12 litres.

Motor Unit

Robust two-piece designed for cool, quiet and continuous operation.

Motor

L5M, L5T: 250W (0.33 hp) 220 volt, single phase (110 volt optional) 50/60 Hz. Nominal maximum speed 8000 rpm (6000 rpm under full load).

L5M-A: 750W (1 hp) 220 volt, single phase (110 volt optional) 50/60 Hz. Maximum speed.

Speed Control

Infinitely variable electronic speed control with integral on/off switch.

Electric Rise & Fall Bench Stand

The mixing unit may be effortlessly raised and lowered using the push-button control on the motor unit.

Construction

All wetted parts are in grade 316 stainless steel with the exception of the bush, which may be bronze alloy or PTFE.

L5 Series mixers are finished in a tough, easy-to-clean, non-chip white nylon coating.

The flat base is covered by a removable non-slip mat, which is resistant to most solvents.

Assemblies

Over 40 heads available.

 **Laboratory Mixers**
L5 Series

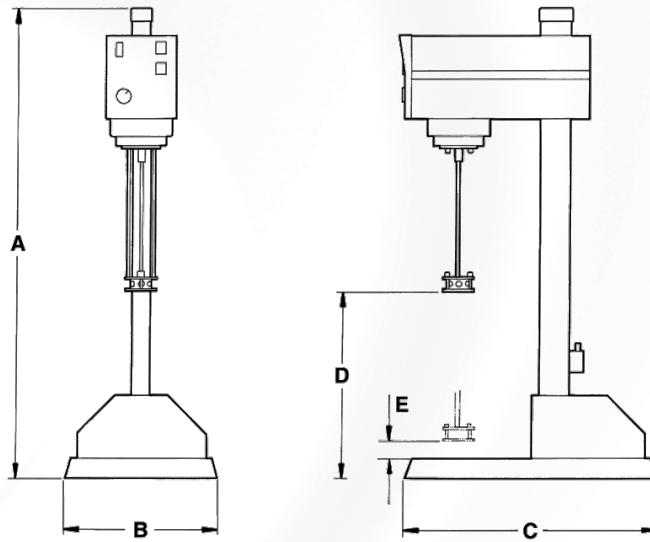

Model	A	B	C	D Max. Height	E Min. Height
L5 Series	940	305	508	330	30

All dimensions shown are in millimetres. The dimensions shown are approximate only and certified diagrams should be used for installation purposes. Silverson reserves the right to change dimensions and specifications without notice.