

UNIXX HTe(p)20

SEMI-AUTOMATIC TEMPERATURE SYSTEMS

BENEFITS

- ÷ Single sided baking modules
- ÷ Different systems for substrates:
up to 200 (300 or 450 mm)
- ÷ Electronic or pneumatic driven
lifting pins
- ÷ Stainless steel lift pins with
different top inserts
- ÷ Controller unit:
semi-automatic or manual
- ÷ Vacuum channels for substrate fixing
- ÷ Integrated fume exhaust
- ÷ Optional:
 - Nitrogen purge (N2)
 - Lift pins for edge handling
- ÷ Designed for R&D and low
volume production



*UNIXX HTp20
Laboratory table-top version
with pneumatic lift-pins*

*UNIXX HTe20
Laboratory table-top version
with electronic lift-pins*

**TEMPERATURE MODULE (ELECTRONIC)
HOTPLATE SYSTEM WITH
ELECTRONIC (PROGRAMMABLE)
LIFT PINS.**

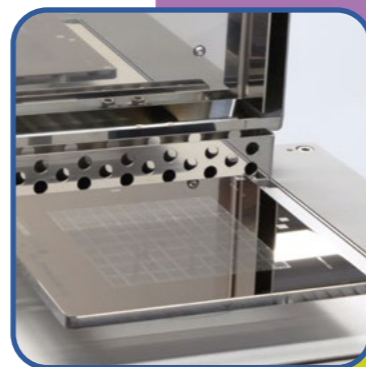
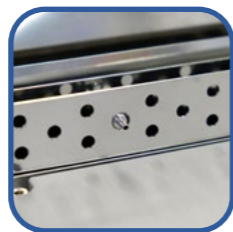

SUBSTRATES UP TO 200 MM / 8 INCH

SEMI-AUTOMATIC SINGLE-SIDED BAKING SYSTEM

Designed to be used:

SOFTBAKE (PRE-BAKE)

HARDBAKE

OPTIONAL FOR HMDS (HEXAMETHYLDISILAZANE):

VAPOR PRIMING, VACUUM DRYING

PROPERTIES (UNIXX HTe20)

- ÷ Heating plate module (up to 300°C)
- ÷ Electronic driven lifting pins
- ÷ Lift pins standard made of stainless steel and PEEK tips (max.250°C)
- ÷ Lift pins, programmable (speed and steps for different stops)
- ÷ Vacuum channels on hotplate surface for substrate fixing
- ÷ Manually operated hotplate cover
- ÷ Integrated fume exhaust

Semi-automatic controller unit:

- ÷ 7inch color touch screen as user terminal
- ÷ Recipe editor to write, manage and configure
- ÷ Actual visualization for effective process monitoring
- ÷ Library function for recipes, flows, log file (e.g. error tracking history).
- ÷ User management with password-protected service access
- ÷ Update & backup function via USB or intranet connection
- ÷ Uninterruptible power supply (UPS) support for all data storage on SD-Card

Options:

- ÷ Pin tips available with other material.
- ÷ Edge handling with edge-grip as RUBBER or PEEK tips.
- ÷ Proximity balls
- ÷ Nitrogen purge (N2)
- ÷ HMDS hotplates (only available in stand-alone unit)
- ÷ Heating plates with higher temperatures (up to 600°C)
- ÷ Vacuum pump

**IDEAL FOR
R&D AND
LOW VOLUME
PRODUCTION**

**TEMPERATURE MODULES
(ELECTRONIC)** up to 200 or up to 300mm

The temperature modules are designed for single-sided baking of substrates, used for pre- and post-bake or dehydration-bake processes. Especially for the priming with adhesive (HMDS; Hexamethyldisilazane) osiris offers hotplate modules for vapor priming or vacuum drying.

Baking modules with electronic, programmable lifting pins are equipped with a touch screen for operation. The osiris software provides simple and convenient process control and recipe creation. A user-friendly and self-explanatory interface underlines the ease of use and makes process flows controllable at any time.

These temperature modules are available in different versions as bench mounted, table-top or stand-alone unit.

TECHNICAL DATA (UNIXX HTe20)

GENERAL

Substrate size:	up to Ø200 mm (Ø8") or 200x200 mm (8x8 inch)
Temperature Range:	up to 300°C*, adjustable in 1°C steps
Accuracy of temp.:	< ±1°C at 100°C
Lifting pins (one set):	Ø50 mm (Ø2") up to Ø200 mm(Ø8") or 200x200mm (8x8 inch)
Hotplate surface:	made of hard anodized aluminum
Hotplate cover:	made of micropolished stainless steel
Table-top housing:	made of PP white
Controller unit:	7inch touch screen

*with top PEEK tips max. 250°C and HMDS-priming max. 120°C

REQUIREMENTS

Voltage:	230 (110) VAC / 1Ph / N / PE / 50(60) Hz
CDA:	8 bar, Tube OD Ø6 mm
Vacuum:	-0.8 bar / -600 Torr, tube OD Ø6 mm
Exhaust hotplate:	1 x OD Ø40 mm, 80 m³/h
Nitrogen (optional):	4 ± 2 bar, tube OD Ø6 mm

DIMENSIONS (WxDxH) approx.

Hotplate module:	340 x 370 x 325/650 mm (13.4 x 14.6 x 12.8/25.6 inch)
Housing table-top:	340 x 510/580 x 340 mm (13.4 x 20.0/22.8 x 13.4 inch)
Height (lid open):	640 mm (25.2 inch)

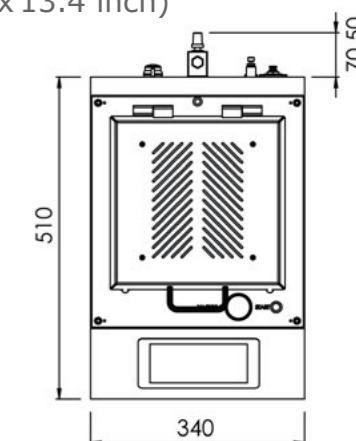
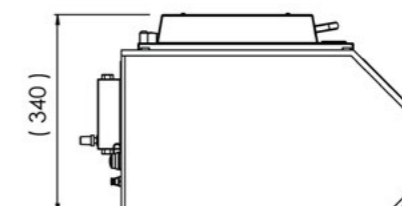
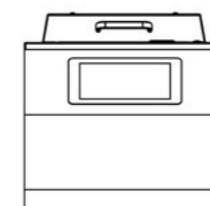

TEMPERATURE MODULE (PNEUMATIC) HOTPLATE SYSTEM WITH PNEUMATIC LIFT PINS.

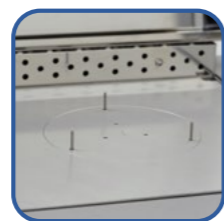

PROPERTIES (UNIXX HTp20)

- ÷ Heating plate module (up to 300°C)
- ÷ Pneumatic driven lifting pins
- ÷ Lift pins standard made of stainless steel and PEEK tips (max. 250°C)
- ÷ Vacuum channels on hotplate surface for substrate fixing
- ÷ Manually operated hotplate cover
- ÷ Integrated fume exhaust

Manual controller unit:

- ÷ 1x PID controller for temperature control at high measuring. The setpoints and parameters determining the process are adjusted with a 5-field plastic foil keyboard.
- ÷ 1x Timer switch with two adjustable derivative timers and two elapsing timers and the possibility to set of various parameters. The timer can be started and stopped both with the front buttons and with the switching inputs.

Options:

- ÷ Pin tips available with other material.
- ÷ Edge handling with edge-grip as RUBBER or PEEK tips.
- ÷ Adjustable proximity bake by microcrew
- ÷ Proximity balls
- ÷ Vacuum pump

**FOR NEW
DEVELOPMENTS
IN PRODUCT
TECHNOLOGY**

TEMPERATURE MODULES (PNEUMATIC) up to 200 or up to 300mm

The temperature modules are designed for single-sided baking of substrates, used for pre- and post-bake processes.

Baking modules with pneumatic lifting pins are equipped with a manual PID controller and a timer switch. This micro-processed (PID) controller serves for temperature control at high measuring accuracy. The setpoints and parameters determining the process are adjusted with a 5-field plastic foil keyboard.

The freely programmable timer switch has two adjustable derivative timers and two elapsing timers. Together with the possibility of various parameters, two output contacts and two switching inputs will allow the employment of any applications one can think of. The timer can be started and stopped both with the front buttons and with the switching inputs.

SUBSTRATES UP TO 200 MM / 8 INCH

MANUALLY CONTROLLED SINGLE-SIDED BAKING SYSTEM

Designed to be used:

SOFTBAKE (PRE-BAKE)

HARDBAKE

OPTIONALLY, OSIRIS ALSO OFFERS HEATING PLATES WITH TEMPERATURES UP TO 600°C.

TECHNICAL DATA (UNIXX HTp20)

GENERAL

Substrate size:	up to Ø200 mm (Ø8") or 200 x 200 mm (8x8 inch)
Temperature Range:	up to 300°C*, adjustable in 1°C steps
Accuracy of temp.:	< ±1°C at 100°C
Lift pins (one set):	Ø50 mm (Ø2") up to Ø200 mm(Ø8") or 200 x 200mm (8 x 8 inch)
Hotplate surface:	made of hard anodized aluminum
Hotplate cover:	made of micropolished stainless steel
Table-top housing:	made of PP white
Controller unit:	1x PID controller, 1x Time switch

*with top PEEK insert max. 250°C

REQUIREMENTS

Voltage:	230 (110) VAC / 1Ph / N / PE / 50(60) Hz
CDA:	8 bar, Tube OD Ø6 mm
Vacuum:	-0.8 bar / -600 Torr, tube OD Ø6 mm
Exhaust hotplate:	1 x OD Ø40 mm, 80 m³/h

DIMENSIONS (WxDxH) approx.

Hotplate module:	340 x 370 x 325/650 mm (13.4 x 14.6 x 12.8/25.6 inch)
Housing table-top:	340 x 510/580 x 340 mm (13.4 x 20.0/22.8 x 13.4 inch)
Height (lid open):	640 mm (25.2 inch)

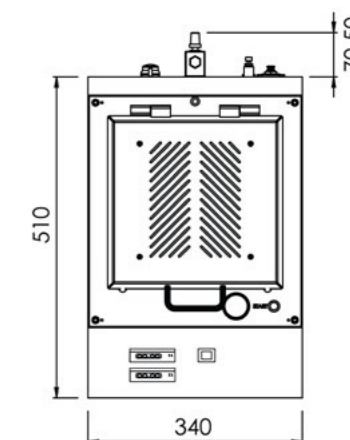
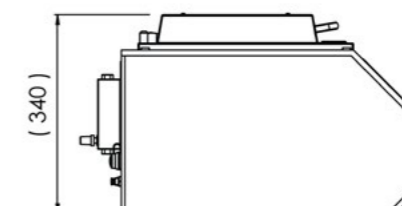

UNIFORMITY

SEMI-AUTOMATIC TEMPERATURE MODULES (ELECTRONIC)

The osiris software with the semi-automatic control unit offers a graphical representation of the ramp-up time & heating-up time, as well as the exact temperature of the hotplate surfaces during the process.

ACTUAL VISUALIZATION FOR EFFECTIVE TEMPERATURE MONITORING.

Measure tool: PT100 surface contact

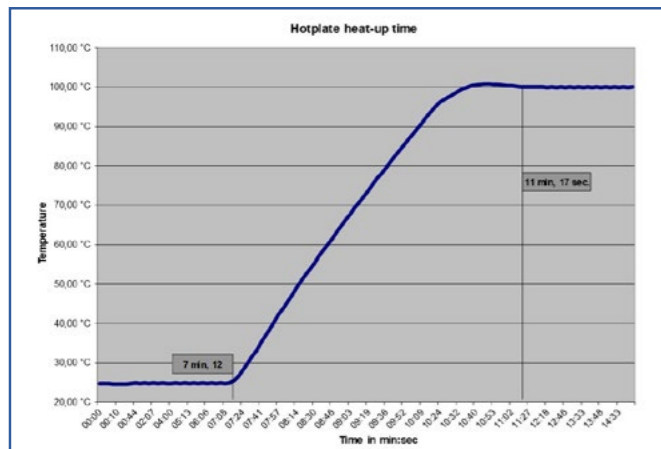

25°C up to 100 °C, ramp-up time after 4 min.

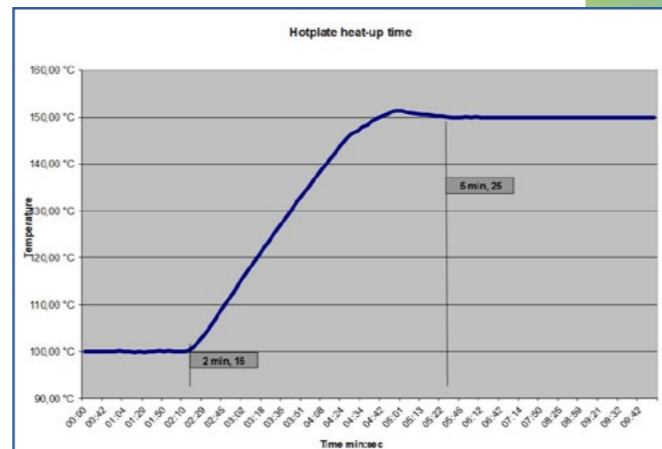

100°C up to 150°C, heating-up speed < 4min.

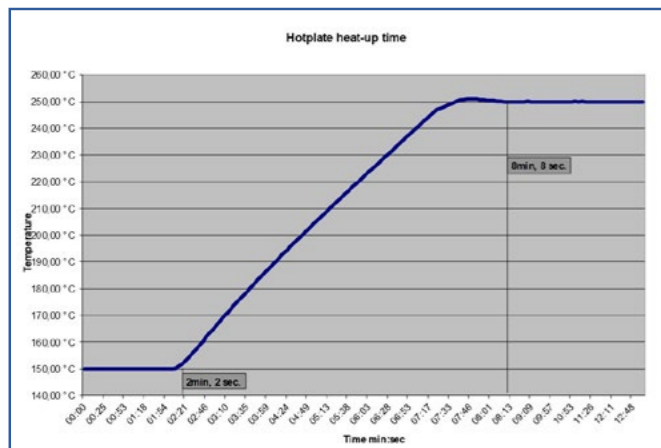

150°C up to 250°C, heating-up speed 6 min.

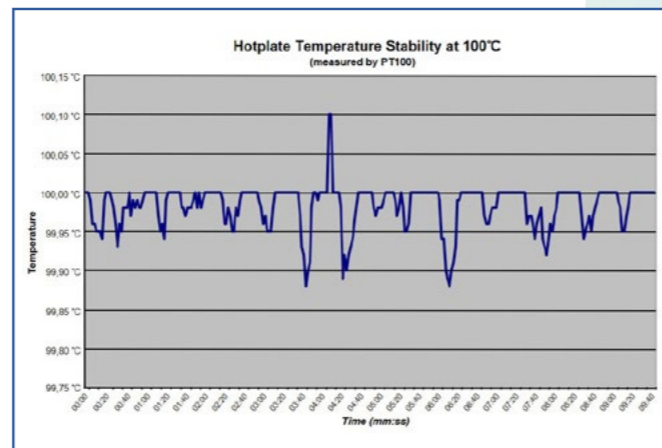

Fixed temperature stability of 100°C, < +/- 0.5°C



UNIXX-HOTPLATES 20/30/45

SEMI-AUTOMATIC SINGLE-SIDED BAKING SYSTEMS

BENCH MOUNTED MODULES

UNIXX HBe20 Ø200 (300 mm) with electronic, programmable lift pins. *semi-automatic control unit*



UNIXX HBp20 Ø200 (300 mm) with pneumatic lift pins. *manual control unit*

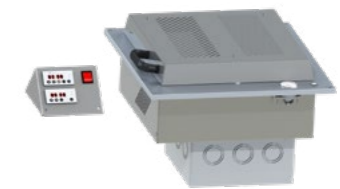

TABLE-TOP SYSTEMS

UNIXX HTe20 Ø200 (300 mm) with electronic (programmable) lift pins. *semi-automatic control unit*



UNIXX HTp20 Ø200 (300 mm) with pneumatic lift pins. *manual control unit*



STAND-ALONE SYSTEMS

UNIXX SHp22+ (Ø200 mm) Spin coater & hotplate with pneumatic lift pins. *semi-automatic & manual control unit*



UNIXX He45 (Ø450 mm) with electronic, programmable lift-pins. *semi-automatic control unit*





OFFICE LOCATIONS

GERMANY

Osiris International GmbH
Josef-Schüttler-Str. 2
78224 Singen Htw. | Germany

🏠 +49 7731 16 995 0

✉️ info@osiris-nano.eu

🌐 www.osiris-nano.eu

Osiris International GmbH
Köpenicker Str. 325 | Haus 3
12555 Berlin | Germany

🏠 +49 30 25 55 904 0

✉️ info@osiris-nano.com

🌐 www.osiris-nano.com

USA

Osiris International Inc.
Cave Creek AZ 85331
United States

🏠 (602) 524 9731

✉️ info@osiris-nano.com

🌐 www.osiris-nano.com

Version: UNIXX-HTe(p)20-datasheet-osiris-200630

Data, design and specification of custom built machines depend on individual process conditions and can vary according to equipment configurations. Not all specifications may be valid simultaneously. Illustrations in this brochure are not legally binding. Osiris International GmbH reserves the right to change machine specifications without prior notice.