



主要特点

- 风速和风向
- 温度
- 湿度
- 具有SDI-12输出
- Gill ASCII 输出
- 大气压力
- 露点温度（计算）
- 结构紧凑，坚固耐用
- 具有NMEA 输出

MetPak weather station utilises Gill WindSonic ultrasonic technology, a highly accurate barometric pressure sensor and a Rotronic Hygroclip HC2-S3 temperature/humidity probe. The design of the MetPak allows measurements to be as accurate as possible without influencing other measured parameters yet provides a compact, reference quality system. The unit is especially suitable for harsh or marine environments.



Base Station Options Available

MetPak can be configured with a fixed or remote wind sensor. See page 3 for all wind sensor options.



MetPak 安装示意图

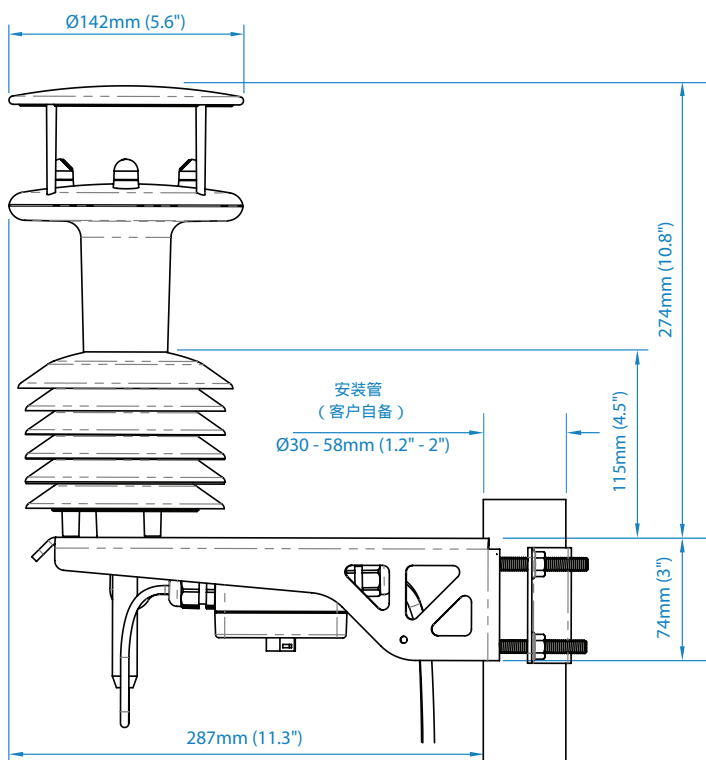

附件包括：

- MetSet 设置软件
- MetView 数据显示、存储软件
- 安装配件

可选附件：

Heater Interface Box

Ease of connection for remote heated wind sensors.

MetPak integrates industry leading products in a convenient, economical package allowing users to concentrate on the measurement rather than the quality of the measurement. Calibration services available from Gill.

Wind Measurement

Parameters	Wind speed & direction or U & V (Vectors)
Units of measure	m/s, knots, mph, kph, ft/min

	Wind Speed	Wind Direction
Range	0-60m/s (134 mph)	0 to 359° - No dead band
Accuracy	±2% @12m/s	±3° @12m/s
Resolution	0.01m/s (0.02 mph)	1°

Air Temperature

Air temperature	Pt100 1/3 Class B
Range	-35°C to +70°C
Accuracy	±0.1°C
Resolution	0.1°C (0.1°F)
Units of measure	°C or °F

Relative Humidity

Range	0-100% RH
Accuracy	±0.8% @ 23°C
Resolution	0.1% RH
Units of measure	% RH
Compensated for temperature dependency	

Barometric Pressure

Range	600-1100hPa
Accuracy	±0.5hPa
Resolution	0.1hPa
Units of measure	hPa, mbar, mmHg, InHg
Compensated for temperature dependency -30°C to +70°C	

Dew Point

Resolution	0.1°C (0.1°F)
Units of measure	°C or °F
Accuracy	±0.15°C (23°C ambient temp @ 20°C dew point)

Specifications may be subject to change without prior notice.

Power Supply

Input voltage	5V to 30V
Current	< 16mA (Output 1 second) @12 V
SDI-12	
Input voltage	12V nominal (9.6-16 V)
Current	< 6.5mA Low power operation

Outputs

Digital outputs	RS232, RS422, RS485* or SDI-12 (user selectable) *2 wire point to point
Baud rates	4800-57600 (ASCII) or 1200 (SDI-12)
Protocols	ASCII, SDI-12 V1.3 or NMEA 0183
Data output	1s, 2s, 4s or polled mode

Environmental

Protection class	IP65
EMC	EN 61326
Operating temperature	-35°C to +70°C
Storage temperature	-40°C to +80°C
Operating humidity	0% to 100% humidity

Mechanical

External construction	UV stabilised white thermoplastic
Fittings	Anodised Aluminium bracket to allow fitting to 30 mm to 58 mm mast dimensions
Weight	2.1kg (including bracket)

Software

MetView	Free software for the display of data and logging
MetSet	Free software for the configuration of the MetPak, MetPak RG & MetPak Pro

Optional Accessories

Cables	15m Power & Data cable USB Configuration cable
Hardware	Heater Interface Box



Gill Instruments Ltd

Saltmarsh Park • 67 Gosport Street • Lymington • Hampshire • UK • SO41 9EG
Tel: +44 (0) 1590 613 500 • Fax: +44 (0)1590 613 555 • Email: met@gill.co.uk

www.gill.co.uk

Copyright © Gill Instruments 2013
D212 - Iss 2

Gill Instruments Ltd. Reg No. 2281574 Registered Office: The George Business Centre, Christchurch Road, New Milton, BH25 6QJ



Wind Sensor Options

Base Station

MetPak is available as a Base Station which enables the system to be specified with a remote wind sensor if required. This sensor can be positioned away from the Base Station and a connection cable is provided. The Base Station has been tested in accordance with BSEN 60945 and is suitable for use in marine environments. This system can also be specified without a wind sensor if wind measurement data is not required.

The MetPak can be specified with a remote sensor from any of the options below:



Wind Sensor Options



WindSonic™

For wind speed and direction measurements to 60 m/s. Corrosion free, polycarbonate housing.



WindSonic™ M

Wind speed and direction measurements to 60 m/s with heating and impact resistant to UL2218 Class 1 & BSEN 60945.



WindObserver™70

With enhanced heating and wind measurements up to 70 m/s for extreme conditions.



WindMaster™

Three dimensional wind measurements up to 45 m/s in a lightweight carbon fibre/aluminium construction.



WindMaster™ PRO

Three dimensional wind measurement up to 65 m/s in a stainless steel housing.

Output rate from the wind sensors is controlled by the Base Station.



Gill Instruments Ltd

Saltmarsh Park • 67 Gosport Street • Lymington • Hampshire • UK • SO41 9EG

Tel: +44 (0) 1590 613 500 • Fax: +44 (0)1590 613 555 • Email: met@gill.co.uk

www.gill.co.uk

Copyright © Gill Instruments 2013
D212 - Iss 2

Gill Instruments Ltd. Reg No. 3154453 Registered Office: The George Business Centre, Christchurch Road, New Milton, BH25 6QJ

