

LEDGON 100

Goniophotometer

Product highlights

- Accurate determination of the luminous intensity distribution and luminous flux at LEDs and small LED modules
- Angular-resolved analysis of spectral and colorimetric quantities
- Type C configuration with motorized phi and theta axis
- Compatible with all spectrometers manufactured by Instrument Systems
- Data export in IES and EULUMDAT format



The compact LEDGON Goniophotometer was specially developed for analysis of angle-dependent spatial radiation patterns from individual LEDs and small LED modules. The entire hemisphere can be measured in the forward direction of the LED. The angular resolution of 0.1° means that exact measured values can be obtained even for narrow-angled LEDs with a high level of reproducibility.

Combined with a spectroradiometer from Instrument Systems, all spectral parameters, for example color coordinates or color temperature can be measured as a function of angle. Particularly in the case of white LEDs, these parameters can undergo significant change depending on the observation angle. Knowledge of this characteristic property is extremely important for using white LEDs in illumination technology.

Equipment setup: light-tight without dark room

The unit comprises a flat optical bench and a goniometer unit with two angular axes that is mounted at one end of the bench. One of the rotation stages has a hollow shaft where an LED test socket (any socket except LED-850) from Instrument Systems can be mounted. An optical probe is positioned at the other end of the optical bench allowing the distance to the LED to be set at between 5 and 50 cm. Two baffles can be variably positioned at any point to eliminate stray light.



LEDGON connected to spectrometer

The entire setup is located in a light-tight enclosure with a folding lid which eliminates the need for a dark room. If larger measuring distances are required, an opening in the side wall of the LEDGON 100 also allows light to be measured from outside.

The goniometer unit

The fixed goniometer unit allows the test specimen to be rotated through two axes: the phi and the theta axis. The phi axis permits the specimen to be rotated through a full

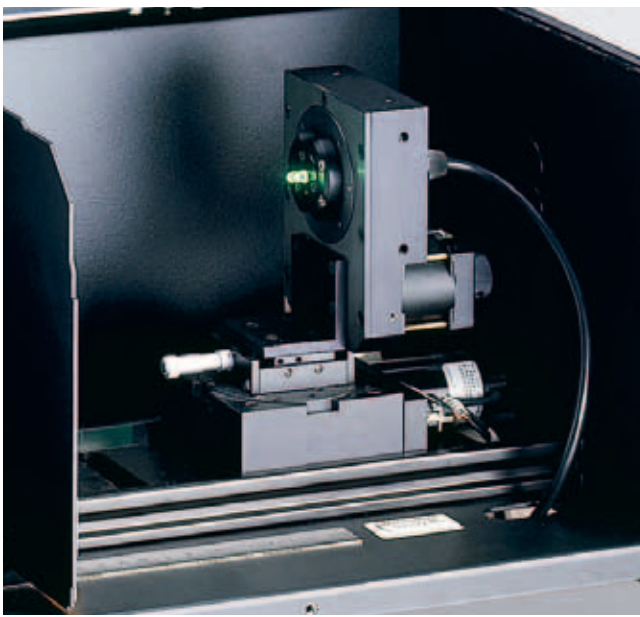

Goniometer unit

360° in the mechanical axis of the test specimen, while the theta axis can be moved perpendicular to this in an angular range of +/- 100°. The angular accuracy is 1° for the phi axis and 0.1° for the theta axis.

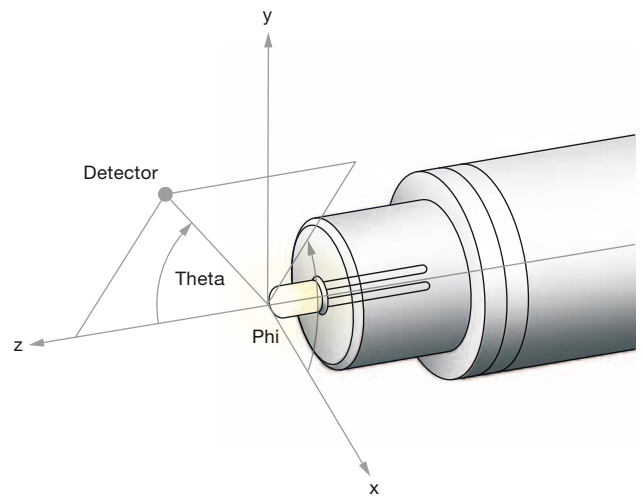

Solid angle definition for phi and theta

Options and accessories

An optional sample table (LEDGON-130) also permits measurement of LED arrays and small modules. This sample table can be upgraded with an XY translation stage (LEDGON-131) so that e.g. an LED module located off-center can be positioned in the center of rotation.

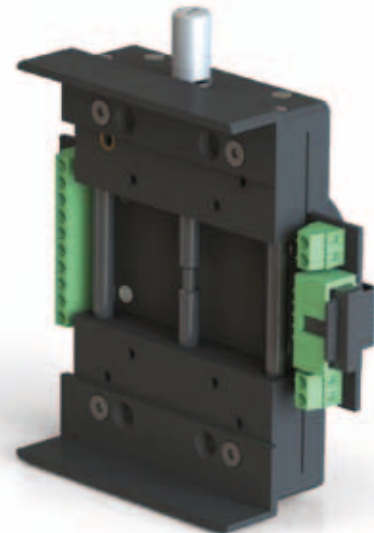

Optional sample table LEDGON-130

Optical probes with diffusers (LEDGON-120 and LEDGON-121), and an optical probe optimized for modules (LEDGON-125) can be supplied for measuring light radiation. The latter is based on a small integrating sphere that allows accurate measurements to be obtained also for test specimens radiating light from an extended surface.



Optical probe LEDGON-120

The LEDGON 100 is compatible with all spectrometers supplied by Instrument Systems. The CAS 140CT is ideal because it has a very large dynamic measuring range. This permits fully automated measurement of the radiation pattern, even for test specimens where the intensity varies significantly over the angle.

Control and evaluation functionalities with SpecWin Pro software

The LEDGON 100 is operated using SpecWin Pro Software from Instrument Systems. Two control modes are available:

- The sequence mode that allows the radiation pattern of the test specimen to be recorded for the two spatial axes (theta and phi) at equidistant angular increments. Parameters can be saved for subsequent evaluations.
- The test series mode, which permits free definition of test sequences, i.e. measurements at any definable sequences of angular positions.

Other add-ons of SpecWin Pro software and appropriate instrumentation also permit current, voltage and temperature to be included in the goniometric analysis, as well as control and measured variables. For example, Keithley 2400 and Keithley 2600 sourcemeters can be easily installed as an add-on.

Accurate measurements of luminous flux and radiant power

The LEDGON 100 Goniophotometer is also ideal for precise measurement of radiant power and luminous flux. Potential measuring errors that can be caused by the geometry of integrating spheres are not encountered with goniometric measurement of luminous flux. Instrument Systems has developed an appropriate function for SpecWin Pro software that allows fully automated measurement. However, it should be noted that the angular range for the theta axis is $\pm 100^\circ$ and hence a measurement is not possible in 4π .

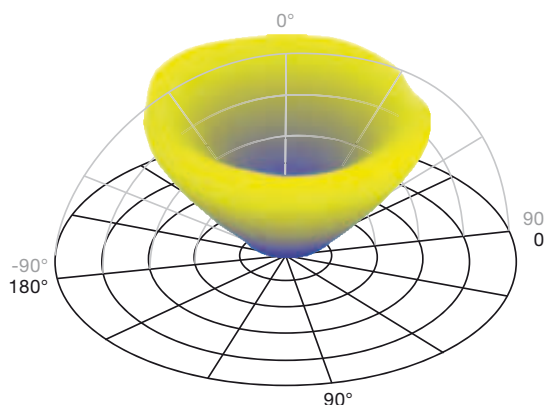

SpecWin Pro 3D radiation pattern

Display options and output formats

The graphics window used to visualize the measurements is the central element of the user interface in the goniometer mode of SpecWin Pro. Five different displays are available for the radiation pattern: a radial, a semi-radial and a cartesian view, a two-dimensional spherical display, and a 3-D view.

Display of the luminous intensity distribution curve is also important for general lighting. The measured data can be exported in the IES and EULUMDAT format for use in simulation programs.

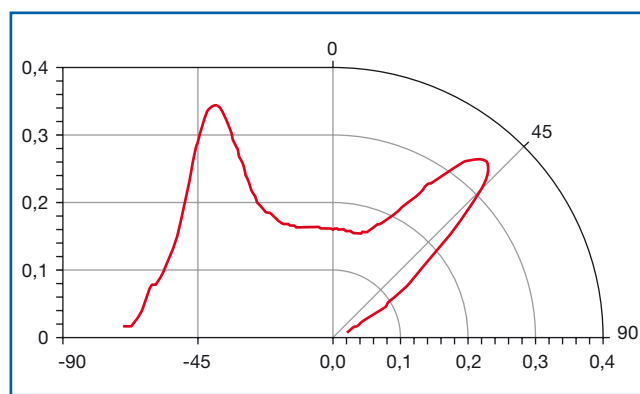

Semi-radial display of the luminous intensity distribution curve

Technical data and specifications

| LEDGON Goniophotometer | |
|---------------------------------|--------------------------------------------------------------------|
| LEDGON-100 basic unit | |
| Angular range | Theta axis : approx. +/- 100°; phi axis: 360° |
| Angular accuracy | Theta axis : 0.1°; phi axis: 1° |
| LEDGON-130 sample table | |
| Clamping distance | 2 x 15 mm |
| Sample dimension max. | 112 x 112 x 48 mm (W x L x H) |
| Maximum sample weight | 700 g |
| Voltage supply | 10 x 0.1 mm ² max. 1A; 2 x 0.75 mm ² max. 6A |
| LEDGON-131 XY translation stage | |
| Travel range | 49 mm per axis |
| Sample dimension max. | 64 x 85 x 25 mm (W x L x H) |

Ordering information

| Order no. | Description |
|------------|-------------------------------------------------------------------------------------------------------------------------------------------------------------------------------------|
| LEDGON-100 | Goniometer for LEDs and small LED modules; light-tight setup with optical bench (without measuring head); includes stepper motor controller |
| LEDGON-105 | Slit at the side panel of the LEDGON for fiber cable gland |
| LEDGON-120 | Measuring head with diffuser (1 cm ² area); incl. OFG-414 fiber bundle and PLG-410 fiber plug adapter; spectral range 380 - 1600 nm |
| LEDGON-121 | Measuring head with diffuser (1 cm ² area); incl. OFG-424 quartz fiber bundle and PLG-420 fiber plug adapter; spectral range 190 - 1350 nm |
| LEDGON-124 | Rail carrier for mounting the LED25-100 integrating sphere in the LEDGON |
| LEDGON-125 | Complete measuring head comprising ISP25 integrating sphere with 1 cm ² measurement aperture, rail carrier LEDGON-124, OFG-424 and PLG-420; spectral range 220 - 1350 nm |
| LEDGON-130 | Sample table for LED modules and mini displays |
| LEDGON-131 | XY translation stage for assembly on the LEDGON-130 sample table |
| LEDGON-135 | Alignment laser for optical bench in the LEDGON |



Instrument Systems GmbH
 Neumarkter Str. 83
 81673 Munich, Germany
 Tel.: +49 89/45 49 43-0
 Fax: +49 89/45 49 43-11
 Email: info@instrumentsystems.com
www.instrumentsystems.com