

DIAPHRAGM VACUUM PUMP LABOPORT® N 820 G



Technical features

- 100% oil-free transfer – thereby pure transferring, evacuation and compression of gases
- High level of vapor and condensate compatibility
- Ideal for extremely aggressive/corrosive gases and vapors
- ATEX compliant according to Ex II 2/-G IIB+H2 T3 internal atmosphere only
- Integrated gas ballast valve
- Expandable: Separators and/or condensers can be purchased individually at any time and easily fitted, enabling users to build their own customized vacuum system
- 3-color status display for in operation / stand-by / error
- Integrated rotational speed control
- Environmentally friendly
- Start against ultimate vacuum of the pump

Technical data

Flow rate [m ³ /h] at atm. pressure	1.2
Flow rate [l/min] at atm. pressure	20
Ultimate vacuum [mbar abs.]	6.0
Operating pressure [bar]	0.1
Voltage [V]	100 – 240
Frequencies [Hz]	50/60
Protection class	IP30
Power P _i [W]	60
Operating current [A]	0.35 (240 V AC) 0.66 (100 V AC)
With thermal switch and power fuse	

MATERIALS

Pump head	TFM™ PTFE
Diaphragm	PTFE-coated
Valves	FFPM

OTHER DATA

Weight [kg]	8.8
Hose connections	ID 9.5 – 8, PVDF
Dimensions W x H x D [mm]	163 x 220 x 259
Permissible media and ambient temperature [°C]	+5 to +40

ACCESSORIES AND SPARE PARTS

ACCESSORIES AND SPARE PARTS	ID
Spare parts kit	317435
Hose connector	317278
Key for hose connector*	316279
Silencer*	322528
Connection cable (for combination with VC 900) 2 m	323829
Connection cable (for combination with VC 900) 5 m	323830

*Part of the scope of delivery

Possible combinations

When combined with the VC 900 vacuum control unit and the connection cable, the rotational speed is controlled in accordance with the requirements of the process. Ideal for combining with all common vacuum controllers with valve control.



Dimensions

N 820 G

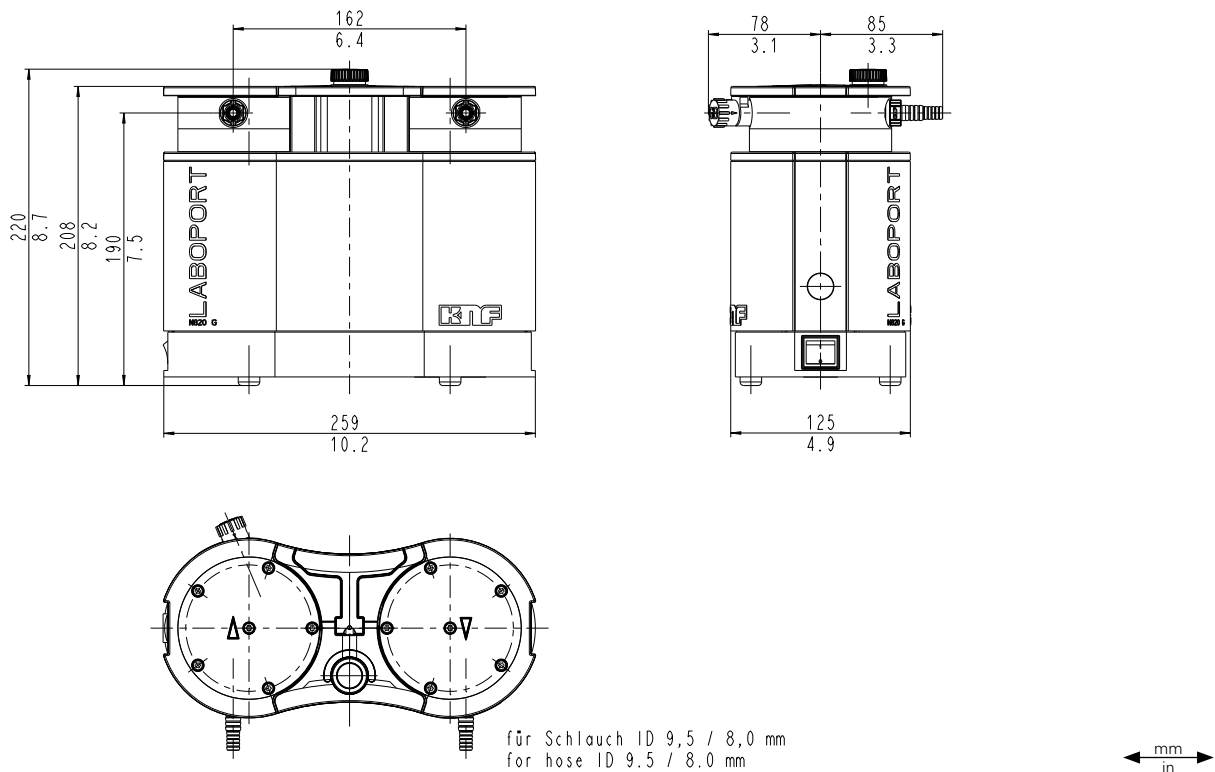

Performance characteristics

PUMP DOWN TIME FOR 20 LITER RECEIVER

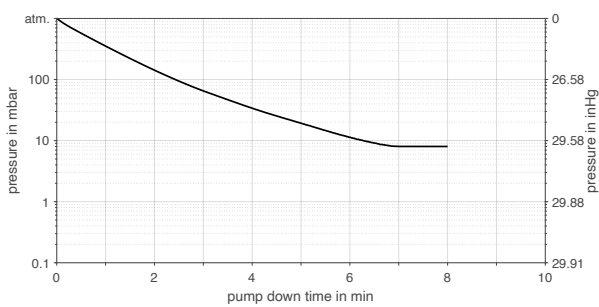

SUCTION PUMPING SPEED AT MIN./MAX. MOTOR SPEED

