



SAFEGROW PRO
CO₂ INCUBATORS

DESIGNED FOR COMFORT

With their high performance and high quality the S@fegrow incubators provide the ideal environment for cell growth, whether you are using primary cell lines or stem cells.

Comfort for cells...

The Advanced Direct Heating system, with its 4 independently controlled elements and 7 thermal sensors, provides unparalleled temperature uniformity and the solid-state IR CO₂ sensor guarantees the most precise control on gas levels.

...and users!

The seamless internal chamber and the fully removable shelving system with 4 non-perforated shelves allow for extremely easy and effective cleaning! The integrated on-demand High Temperature Decontamination cycle completes the system allowing to keep contamination events under control!



A NUMBER OF FEATURES DESIGNED TO EASE YOUR WORK

- ✓ Double door design, with fully sealed inner glass door and outer heated door. The S@fegrow PRO can be equipped with an optional 4 inner glass door system.
- ✓ Solid shelves are supplied as standard to provide even surface for the culture vessels (perforated shelves available as optional).
- ✓ Fanless construction, with gentlest possible air movement by thermal convection, ensures low contamination risk, simplifies cleaning and decontamination and allows for long life of incubator components.
- ✓ Seamless, Stainless Steel 304 internal chamber (with fully rounded corners and no internal projections or holes) makes it easy to clean, corrosion resistant and minimize contamination risk.
- ✓ Large 27.5 mm access port allows user to supply power to small instruments placed on the interior, or allows any other utilities access to the incubator chamber.
- ✓ Access to the latest 500 events directly from the control panel for immediate review on incubator's operating status!



Heated external door



Inner Glass Door.
Available also
in 4 slots format



Seamless Chamber
with rounded angles for
easy cleaning



Fully removable
shelving system with 4
non perforated shelves



Passthrough hole
for cables or
external probes

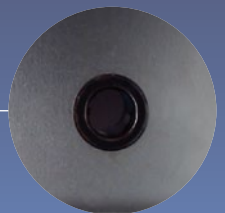

Stainless Steel water pan



AN ELEGANTLY CRAFTED STANDARD CONTROL PANEL AND DISPLAY, FOR YOUR CONVENIENCE

Programmable audio-visual alarm, warning "parameter out of range".
Autoreset after chamber condition recovery.

2 x 24 message centre, with alpha numeric display for setup and status information.



Temperature display
in steps of 0.1°C

Soft keys to access menu
and modify parameters

CO₂ display
in steps of 0.1°C

Italian Quality

S@fegrow Incubators are completely made in Italy using components of Italian or European origins! We use only the best for our incubators!



MAXIMUM CLEANABILITY:

- ✓ The inner chamber is derived from a single sheet of stainless steel, resulting in a seamless surface with big round corners
- ✓ Shelving system is fully removable with no fixtures on the inner chamber's walls
- ✓ Water is placed inside an easily removable and cleanable dedicated steel pan
- ✓ No air circulation channels or conduits

Advanced Direct Heat system:

The Direct Heat system has been designed to provide top level performances in term of uniformity and recovery:

4 independent heaters controllers

➤ maximum precision!

73 meters of heating elements on 6 sides

➤ maximum uniformity!

Infrared CO₂ Sensor:

The humidity independent IR sensor provides high accuracy in CO₂ level measurement, and the programmable AutoZero function makes sure it always works at top performance!

The sensor has been designed in order to allow running the High Temperature Decontamination Cycle without the need to remove it!

High Temperature Decontamination Cycle:

This standard feature of S@fegrow PRO incubators allows to raise the internal chamber temperature to 125°C in order to remove residual contaminations and keep the incubator clean!

Full optional

Access port, RS232 port for connection to data logging systems, Volt-Free connection for external alarms.

FULL PERFORMANCE: NO FANS ATTACHED!

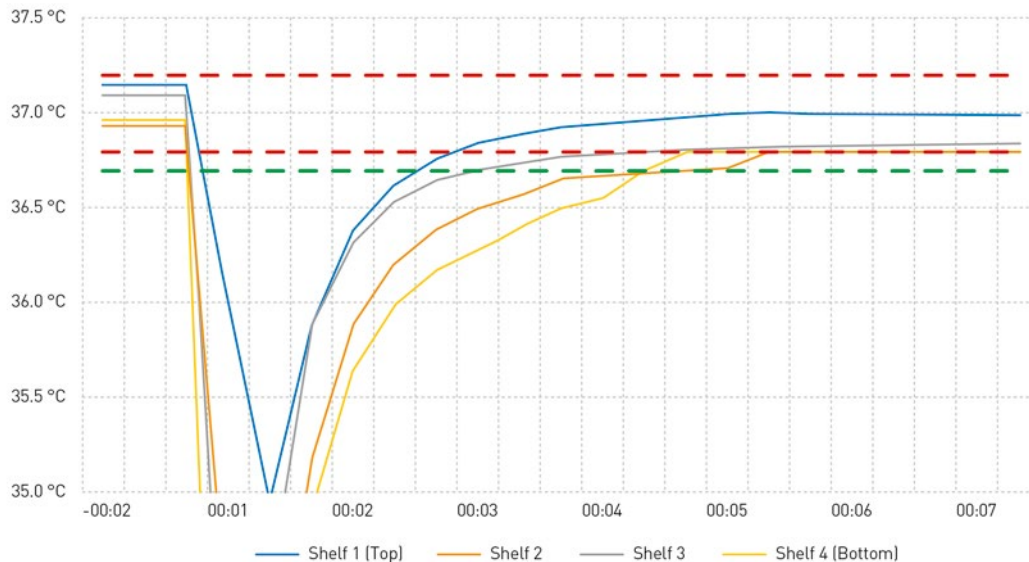

Temperature recovery test: Incubator set point 37°C; Temperature probes: 9 probes/shelf; Room temperature: 21°C; Door opening: 15 seconds. Green dashed line represents nominal uniformity (+/- 0.3°C from set point); Red dashed line is +/- 0.2°C from set point.

S@fegrow's Advanced Heating System has been designed to provide top level performances without requiring any help from active air circulation fans!

The system allows to recover nominal temperature uniformity after only 4 minutes following a door opening of 15 seconds! (see graph, green dashed line) Furthermore in 5 minutes uniformity typically exceeds nominal values! (see graph, red dashed line).

The design of the S@fegrow PRO with 6 sided heating and an independent base heater which gives a temperature boost each time the door is opened, optimises chamber recovery without compromising the design by having to use a fan. Tests have shown that CO₂ homogenises within the chamber almost as soon as the 5% level is reached.

- ✓ The risk of contaminating samples is lowered by allowing the gentlest possible air movement commensurate with providing fast recovery and homogeneous chamber conditions.
- ✓ Cleaning the chamber is far simpler because internal ducting and fan guards are eliminated, also the fan blade, which is impossible to clean properly without removing it and autoclaving.
- ✓ The gentle air movement reduces desiccation of samples to a minimum. The rate of evaporation is in direct proportion to the speed of the air movement within the chamber at constant RH level. Air movement is at least 10 times higher in an incubator with a fan.
- ✓ The usable capacity within the chamber is increased by up to 30% by eliminating ducting and the fan. This optimises the usable volume in a given space, particularly important in a busy laboratory.

UNIFORMITY WHERE IT'S MOST IMPORTANT!

Using perforated shelves creates cold spots due to the different thermal conductivity of air and steel: these may have unwanted effects to cells' growth patterns.

The S@fegrow PRO is supplied with 4 non perforated shelves to increase temperature uniformity where it counts the most: near your cells!!

Moreover the solid surface is extremely easy to clean, keeping the risk of contaminations under control!

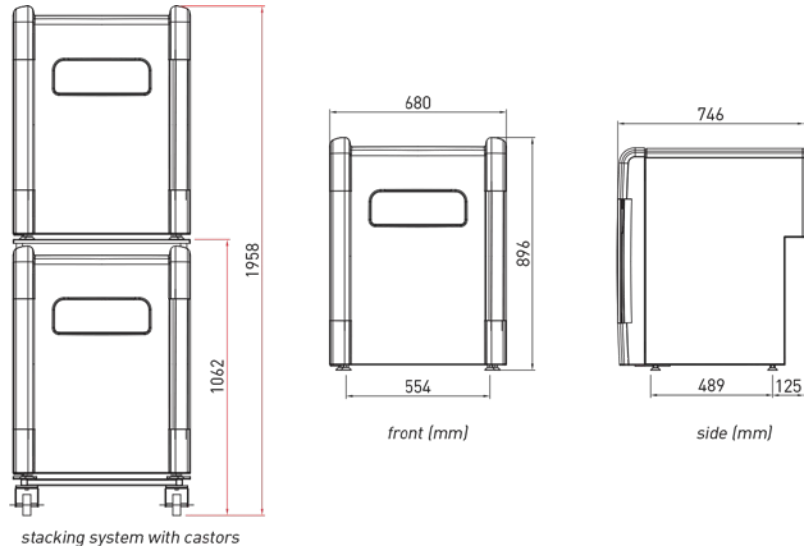

STANDARD UTILITIES

PART NUMBER	
CO20010	S@fegrow PRO - CO ₂ Incubator - 230 Volts, 50/60 Hz - Double Door w/Glass - Right open (hinges on the left) – HT Decontamination
CO20011	S@fegrow PRO - CO ₂ Incubator - 230 Volts, 50/60 Hz - Double Door w/Glass - Left open (hinges on the right) – HT Decontamination

OPTIONS & ACCESSORIES

PART NUMBER	DESCRIPTION
COA08100	Stacking kit for S@fegrow, composed of base with castors and intermediate plate
COAP004	Inner glass door. 4 doors version for S@fegrow mod.: CO20010
COAP005	Inner glass door. 4 doors version for S@fegrow mod.: CO20011
COA0040	Set of 4 perforated shelves for S@fegrow
COA08105	Inlet CO ₂ Filter for S@fegrow
COA08106	Autozero Filter for S@fegrow
COA08111	5,0% CO ₂ Small Bottle for analyzer calibration
AS70001	Stand w/castors for S@fegrow, height 540 mm

TECHNICAL DATA

TEMPERATURE CONTROL	
Temperature range	10-50° C in 0.1 increments (minimum setting: ambient +5° C)
Temperature measurement	Seven RT curve matched thermistors
Temperature control	± 0.1° C
Temperature accuracy	± 0.1° C
Temperature uniformity	Better than ± 0.3° C
Temperature recovery	About 4 minutes following a 15 seconds door opening
Over Temperature protection	Independent, inhibits all heaters above 1.0° C over set temperature value (in the unlikely event of a control system failure)
CO ₂ SYSTEM	
Sensor	Solid State IR Sensor, automatic atmospheric CO ₂ zeroing. Measurement is independent from chamber humidity level
CO ₂ range	0.5 to 20 % CO ₂ , in steps of 0.1%
CO ₂ control	± 0.1% CO ₂
Accuracy	± 0.2% at 5% CO ₂ set point
Recovery rate	About 5 minutes following a 15 seconds door opening
Recovery rate	About 5 minutes following a 15 seconds door opening
RELATIVE HUMIDITY SYSTEM	
Reservoir	2.5 litres, 304 Stainless Steel humidity tray
RH level	Minimum 95% (adjustable in a small range through base heater setting)
DECONTAMINATION CYCLE	
Decontamination cycle type	Fully automatic, 125° C cycle
Temperature ramp up time	1.5-2.5 hours
Exposure time	4 hours
Temperature ramp down time	5-7 hours
Total cycle time	10.5 to 13.5 hours
CONSTRUCTION	
Inner Chamber	304 Stainless Steel, totally seamless
Chamber volume (gross /usable)	188.6 litres/140 litres
Internal Dimensions (W x H x D) mm	530 x 690 x 500
External Dimensions (W x H x D) mm	680 x 896 x 746
Exterior	Powder painted mild steel with ABS plastic outer door cover
Interior access	Heated outer door with direct chamber access or sealed inner glass door (with optional 4 inner glass doors)
Door swing	Right side opening with optional left side door swing (factory fitted)
Net Weight	102 Kg
Packed Weight	135 Kg
SHELVING SYSTEM	
Shelf racks	Easy to assemble, 304 stainless steel construction, with high temperature plastic spacers
Shelf type	Solid (non perforated) stainless steel shelves (perforated available as option)
Shelf dimensions (W x D) mm	510 x 455 mm, with 150 mm height above each shelf
Shelf surface area, Sq meter	0.23 m ² (2.76 sq ft)
Capacity: standard - maximum	4 shelves
ALARM SYSTEM	
Chamber status alarm	Fully programmable, audio-visual, auto reset when chamber conditions resume
Incubator function alarm	Fully automatic alarms to advise failure in heaters or sensors
Alarm events Log	Up to 500 alarm events held in memory on a rolling basis, displayed on 2 x 24 display, showing programmed value, actual value, time and duration of alarm event
POWER REQUIREMENTS	
Voltage	220-240 V, 50/60 Hz
Rated Power	1.5 KW
Power to maintain 37° C	< 0.1 kW
EXTERNAL CONNECTIONS	
RS 232 output	Operating conditions, alarms and events data output
Contact for remote alarm	Volt-free, for wiring to a remote external alarm device or alarm system (BMS)

MORE THAN 40 YEARS OF EXPERIENCE

The experience of **BioAir**® in manufacturing **Biohazard** and **Laminar Air Flow** cabinets goes back to the early 70s', when the brand **Gelaire**® became the "gold standard" for airborne contamination control in many laboratories throughout the world.

A family of **Recirculating Fume Hoods**, based on the adsorption of toxic vapors by means of charcoal filters, was successfully introduced a few years later, thus characterizing the Company as the only one really focused on the protection of the operators and inspired by its motto:

This unique know-how was cherished and brought to an even higher level of quality twenty-five years later, when under the name of **BioAir**®, the entire

range was completely re-designed to meet the growing requirements of the laboratory staff and the most stringent regulations.

At the top of the range, particularly noteworthy are the **Biohazard** (or Microbiological Safety) **Cabinets**, representing the sum of the Company's know-how certified to European standards (EN12469:2000) and complying with the Australian regulations; in other words, they are designed to provide the technicians with the maximum level of safety, when they are used according to GLP/GMP in their respective environments.

Today, in a plant occupying more than 2.800 square meters, **BioAir**® manufactures a complete range



Manufacturing plant: Sizzano (PV), Italy

of microbiological safety cabinets, laminar flow cabinets and fume cupboards, encompassing more than 15 models, with many of them available in different sizes; customized models and/or designed for specific applications can be produced thanks to the competence of a team of skilled engineers and dedicated workers.

The experience deriving from decades of sales and support to Cell Biologists, allowed BioAir® to bring into the market an extremely innovative CO₂ Incubator, the **S@fegrow**, which is the result of a deep knowledge of the best conditions required by the most critical tissue culture methods, supported by the suggestions received from

the scientists involved in growing cells in vitro.

The core business of the recently established **BioAir® Industrial Team** is the design, manufacturing and validation of customized equipment for the protection of the operator and of the product within pharmaceutical and healthcare production facilities.

This dedicated team will take advantage of the long experience and the production capacity acquired through laboratory LAF applications, to offer dedicated and complex equipment, ranging from **dispensing/sampling Downflow Booths** and **Clean Rooms**, to **RABS** and **Isolators** for highly active powder processing.

Manufacturing plant: Siziano (PV), Italy

