



DPSS “eye – safe” 1,5 μm CW erbium laser



FEATURES:

Up to 500 mW of continuous wave power
Compact DPSS design
1522 nm, 1531 nm, 1550 nm or 1602 nm
wavelength models
High beam quality

APPLICATIONS:

Optical instrumentation
Metrology and spectroscopy
Life sciences



**Laser specifications:**

Wavelength	1522 nm	1531 nm	1550 nm	1602 nm
Wavelength tolerance	± 1 nm			
Beam divergence, full angle	<5 mRad			
Beam diameter at exit window	<1 mm			
Beam quality	M2<1,5			
Beam profile	TEM ₀₀			
Polarization ratio	Linear, Horizontal >100:1			
Average output power	300 mW	300 mW	400 mW	300 mW
Power stability (2 hour)	<1 % (after 30 min of warm up)			

Physical dimensions:

Laser module dimensions	175 x 78 x 86 mm (L x W x H)
Laser driver dimensions	164 x 105 x 44 mm (L x W x H)

Utility requirements:

Pump current	5-10 A
Electric	100-240 V AC, 50/60 Hz, 1.4 A
Operating temperature	15 – 25 °C
Cooling	TEC element + air cooling





Laser beam profile:

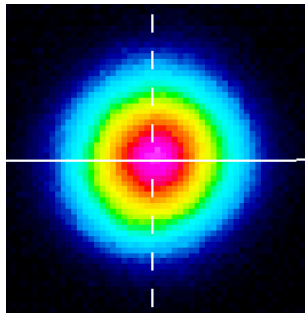

Near field (14 cm from the laser) beam profile

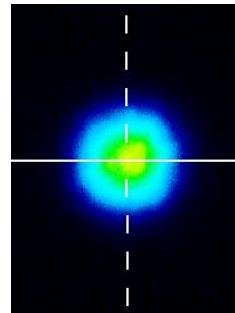

Far field (70 cm from the laser) beam profile

Power stability:

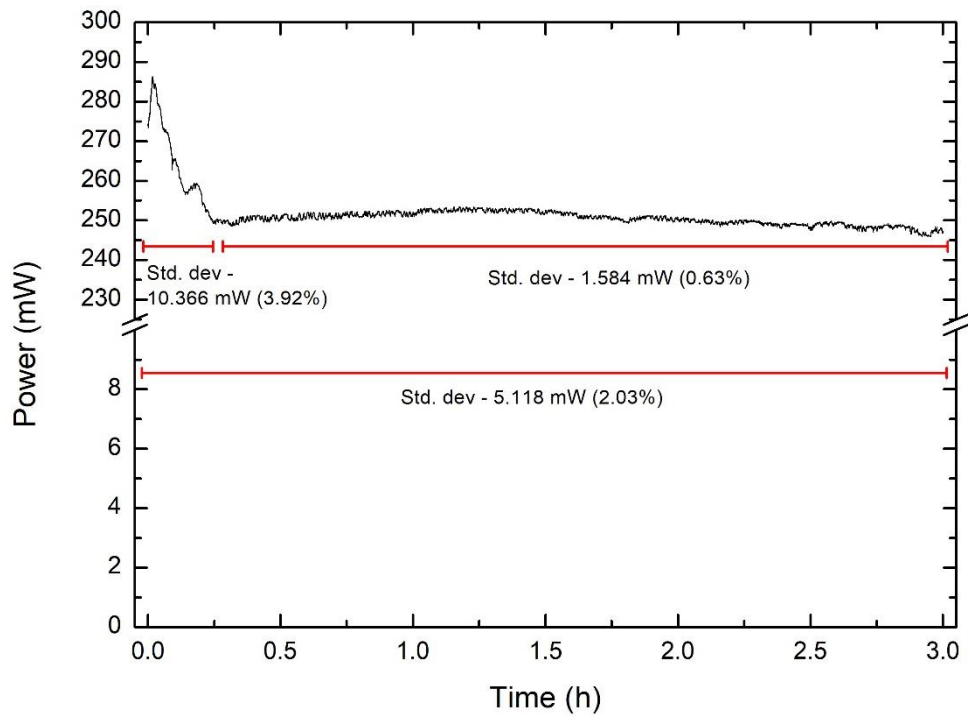

Power stability measurement for 1531 nm laser with 25 min of warm up



Necessary components to run the laser:

 <p>1550 nm DPSS laser*</p>	 <p>Laser driver</p>
 <p>Power supply with cables</p>	 <p>USB-RS232 adapter</p>

*DPSS laser head render does not match with laser head scheme. Please follow the schemes for real laser head dimensions.

Laser head schemes:

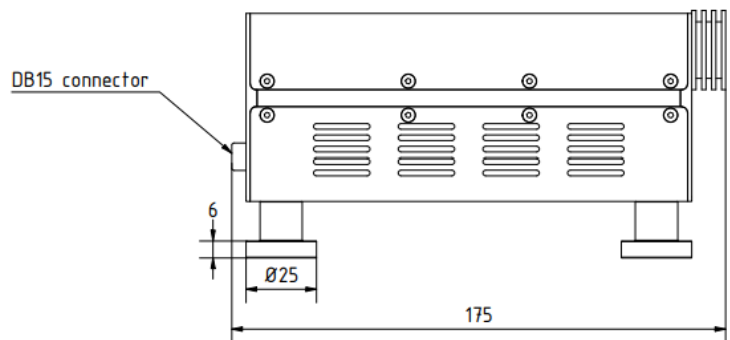
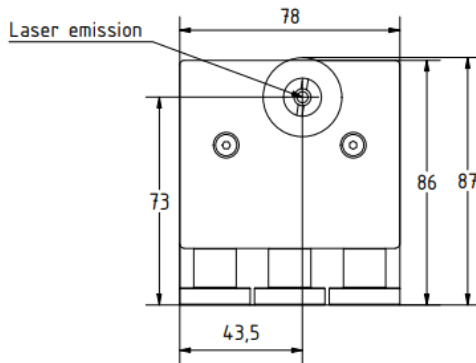

Laser safety class:

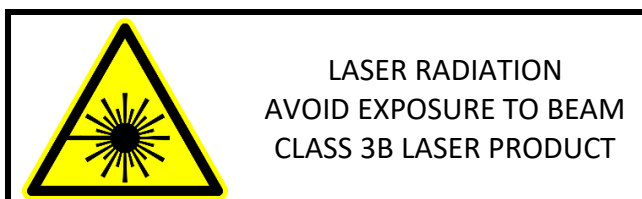



OPTOGAMA



UAB Optogama
Mokslininku str. 2A
LT-08412, Vilnius, Lithuania
sales@optogama.com

Tel.: +370 5 219 4884
Fax.: +370 5 219 4883
Company code: 304023355
VAT ID LT100009337919

Bank details:
IBAN: LT88 7044 0600 0802 0123 with AB SEB
Bank code 70440, Gedimino ave. 12
LT-01103 Vilnius, Lithuania, SWIFT: CBVI LT 2X

