



FOR ALL YOUR METALLOGRAPHIC
NEEDS SINCE 1968

全自动热压镶嵌机 METPRESS



QMAXIS 中国总代理 可脉检测 (南京) 有限公司
QMAXIS Testing (Nanjing) Ltd.



欢迎光临中心实验室体验

全自动热压镶嵌机METPRESS

- METPRESS全自动热压镶嵌机，包括单筒和双筒两款，适用于大量的样品镶嵌工作
- 双筒镶嵌机，每个镶嵌筒可独立控制
- 双筒可选用不同直径的模具
- 每个模具筒用隔板间隔可做2个试样
- 电动液压，无需气源
- 制样速度快，常规制样约8min
- LCD触摸屏，友好的操作界面
- 预设程序，适合重复制样
- 屏幕实时显示当前实际温度和压力，镶嵌过程一目了然
- 模具尺寸齐全
- 冷却模式快、中、慢可选
- 冷却不充分，需要继续冷却时，有提醒功能
- 镶嵌完成后有音频提示
- 滑盖开仓、关仓，省力又方便
- 卡口锁闭加热仓，操作方便，安全程度高
- 防腐蚀不锈钢结构，安全、耐用



关仓

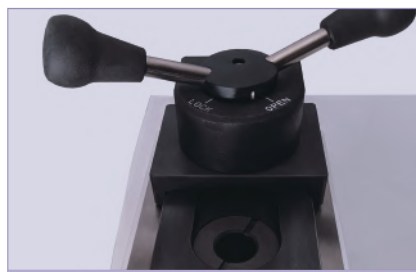

滑盖推开

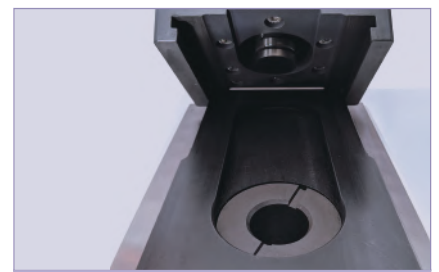

开仓



控制面板



简明的管线



随机附件

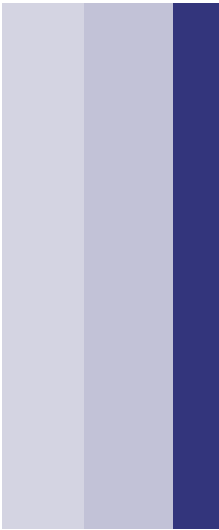

全自动热压镶嵌机METPRESS技术参数

	单筒热压镶嵌机METPRESS A	双筒热压镶嵌机METPRESS-2
每次可制样	2	4
加热功率	1.2kW	1.5kW
预加热		接通电源预加热, 50-90℃
加压系统	电动液压, 无需气源	
镶嵌温度	最大加热到200℃	
镶嵌压力	最大加压到5000psi(345bar)	
镶嵌尺寸	1in, 1.25in, 1.5in, 25mm, 30mm, 40mm	
冷却模式	水冷却, 快、中、慢可选, 未完全冷却有提醒功能	
制样速度	常规制样约8min	
进水口尺寸	8mm	12mm
出水口尺寸	12mm	20mm
电源	220V, 单相, 50Hz	
显示屏	LCD触摸屏	
尺寸 (W×D×H)	448×616×514mm	584×622×508mm
重量	65kg	104kg

全自动热压镶嵌机METPRESS订货信息

产品编号	产品描述
25 01	单筒热压镶嵌机METPRESS A
25 01-2	双筒热压镶嵌机METPRESS-2
25 01-M1	模具1in
25 01-M125	模具1.25in
25 01-M150	模具1.5in
25 01-M25	模具25mm
25 01-M30	模具30mm
25 01-M40	模具40mm

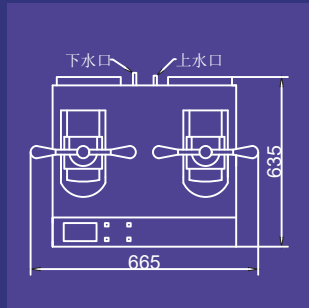
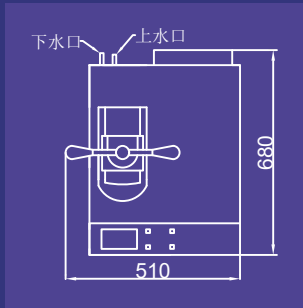

QMAXIS

可脉检测(南京)有限公司
QMAXIS Testing (Nanjing) Ltd.

手机: 186-0255-6086 微信: 18602556086
电话: 025-8776-3131 传真: 025-8662-3131
邮箱: info@qmaxis.cn 网址: www.qmaxis.cn

