

# Turb<sup>®</sup> 750 IR/T

LABORATORY TURBIDIMETER



a xylem brand

**Copyright**

© 2020 Xylem Analytics Germany GmbH  
Printed in Germany.

## Turb<sup>®</sup> 750 IR/T - Contents

<b>Safety</b> .....	<b>4</b>
<b>Display and socket field</b> .....	<b>4</b>
<b>Power supply</b> .....	<b>5</b>
<b>General operating principles</b> .....	<b>5</b>
<b>Initial commissioning</b> .....	<b>8</b>
<b>Operation</b> .....	<b>9</b>
Inserting a cell .....	9
Preparing the cell and sample .....	9
Measuring the turbidity .....	11
Calibration .....	12
<b>Maintenance, cleaning</b> .....	<b>14</b>
Maintenance .....	14
Cleaning .....	15
<b>What to do if...</b> .....	<b>16</b>
General errors .....	16
Turbidity .....	16
<b>Technical data</b> .....	<b>17</b>
General data .....	17
Turbidity (Turb <sup>®</sup> 750 IR) .....	19
Turbidity (Turb <sup>®</sup> 750 T) .....	20



All current data for the Turb<sup>®</sup> 750 IR/T can be found on the Internet under <http://www.WTW.com>:

- Firmware
- Operating manual

More detailed information can be found in the appendix of the detailed operating manual on the CD-ROM provided.

## Safety

### Safety instructions

Safety instructions point out dangers:



#### **WARNING**

indicates a possibly dangerous situation that can lead to serious (irreversible) injury or death if the safety instruction is not followed.



#### **CAUTION**

indicates a possibly dangerous situation that can lead to slight (reversible) injury if the safety instruction is not followed.

#### **NOTE**

indicates a possibly dangerous situation where goods might be damaged if the actions mentioned are not taken.

### Safe operation



#### **CAUTION**

**Danger of eye damage by visible and invisible LED radiation. In the cell shaft of the Turb® 750 IR there are light emitting diodes (LEDs) of the 1M class. Do not look at the radiation using optical instruments. With normal, authorized use there is no hazard.**

### Authorized use

This meter is authorized exclusively for turbidity measurements in the laboratory.

Only the operation and running of the meter according to the instructions and technical specifications given in this operating manual is authorized (see TECHNICAL DATA, page 17).

Any other use is considered unauthorized.

## Display and socket field

### Display

The graphic display shows all information of the current measurement in the measured value display. The illumination enables to read the display even in the darkness.

1 Status display indicators, e.g.:  
 [IRPC] = Intelligent reproducibility and plausibility check  
 [AQA] = Valid AQA check available

2 Measured value (with unit)

3 Status display indicators, e.g.  
 [3-P StdCAL] = Valid calibration available  
 (calibration type: 3-P StdCAL))

4 Status line with date and time

**Socket field**

1 USB-B (micro) interface

2 Power pack

3 RS232 (serial) interface

**Power supply**

The Turb<sup>®</sup> 750 IR/T is supplied with power by the power pack included in the scope of delivery. The batteries (4 batteries 1.5 V Mignon type AA) in the battery compartment supply the integrated clock with power when the power supply is missing.

**General operating principles**

This section contains basic information on the operation of the Turb<sup>®</sup> 750 IR/T.

**Operating modes**

- Measurement

The display indicates measurement data in the measured value display

- Calibration  
The display indicates a calibration procedure with calibration information
- Data transmission  
The meter transmits measuring datasets or calibration records to the serial interface
- Configuration  
The display indicates a menu with further menus, settings and functions

Keypad	<M <sup>(9)</sup> >	Switch to the measured value display
	<CAL <sup>(4)</sup> >	Start calibration
	<QuickCAL <sup>(1)</sup> >	Start simplified calibration with one standard.
	<AQA <sup>(2)</sup> >	Start the checking of the meter with AQA standards. The key is only active if AQA checks were activated.
	<A-Z <sup>(5)</sup> >	Enter letters (This function will be enabled in a future software version.)
	<START/ENTER <sup>(.)</sup> >	Open menus / confirm entries / start measurement
	<MENU <sup>(7)</sup> >	Call up the <i>Configuration</i> menu (all settings are made here)
	<On/Off>	Switch the meter on or off
	<PRT <sup>(8)</sup> >	Output display contents to RS232 or USB interface (e.g. print)
	<STO <sup>(0)</sup> >	Open the <i>Store</i> menu: <STO <sup>(0)</sup> > Quick storing: 2 x <STO <sup>(0)</sup> >
	<STO <sup>(0)</sup> _>	Open the measured value memory
	<▲ <sup>(6)</sup> >, <▼ <sup>(3)</sup> >	Highlight menu items or selection; Set values
	<ESC>	Switch to the next higher menu level / cancel input



Entering numerals with the number keys (see ENTERING NUMERALS WITH THE NUMBER KEYS., page 8).

## Measured value display

## Menus and dialogs

In the measured value display, open the menu with **<MENU (7) >**.

The menus for settings and dialogs in procedures contain further submenus. The selection is made with the **<▲>** **<▼>** keys. The current selection is displayed in reverse video.

- **Menu**

The name of the menu is displayed at the upper edge of the frame. Menus are opened by confirming with **<START/ENTER (.) >**. Example:

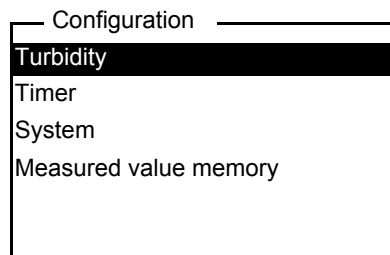

- **Settings**

Settings are indicated by a colon. The current setting is displayed on the right-hand side. With **<START/ENTER (.) >**, the selection of the possible settings is opened. Subsequently, the setting can be changed with **<▲>** **<▼>** and **<START/ENTER (.) >**.

Example:

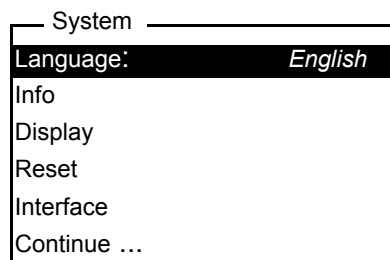

- **Functions**

Functions are designated by the name of the function. They are immediately carried out by confirming with **<START/ENTER (.) >**.

Example: display the *Calibration record* function (in the *Turbidity* menu).

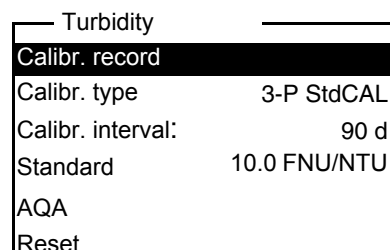

- Messages

Information or operating instructions are designated by the ■ symbol. They cannot be selected.

Example:

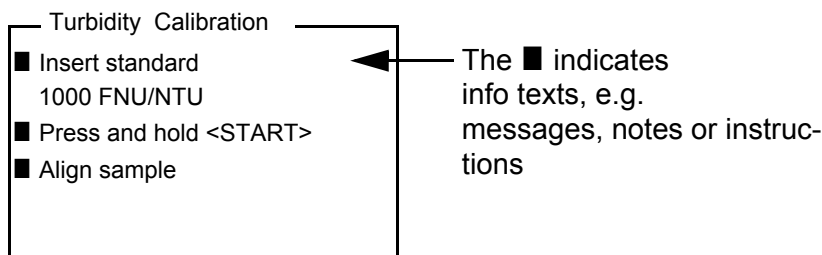

### Entering numerals with the number keys.

Keys with additional characters printed on (orange) are assigned doubly. In the input fields you can directly enter digits with the orange number keys (e.g. date and time). Complete entering a number with the key <START/ENTER (.) >.

When entering numeric values with decimal separators (e.g. turbidity nominal values), pressing <START/ENTER (.) > for the first time will set the decimal separator. Pressing <START/ENTER (.) > for the second time will complete the entering of the numeric value. The numeric value is always displayed with decimal places and, if necessary, rounded.

## Initial commissioning

### Switching on the meter

Press the <On/Off> key.

### Setting the language

The English language is set on delivery. Set a different language as follows:

1. Open the *Configuration* menu with the <MENU <sup>(7)</sup> > key.
  - 1 Open the *Configuration / System / Language* menu with the <▲> <▼> and <START/ENTER (.) > keys.
  - 2 Select the required language with the <▲> <▼> keys and confirm with <START/ENTER (.) >.
  - 3 Quit the menu with the <M <sup>(9)</sup> > key.

### Setting the date and time

The date and time are set in the menu, *Configuration / System / Continue ... / Date/time*.



## Operation

### Inserting a cell

Before using a cell for the first time, determine and mark the suitable measuring position for the cell (see PREPARING THE CELL, page 9).

- 1 Push the dust cover (1) upward.  
The cell shaft for 28 mm cells is open.

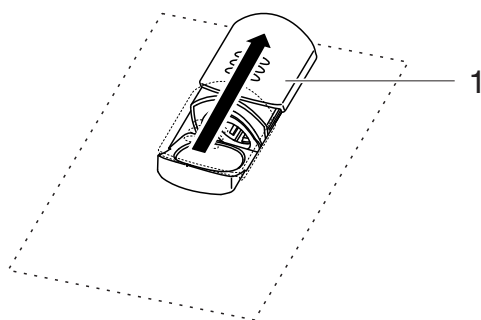

### Inserting a 28 mm cell

- 2 Insert the marked cell so that it is positioned on the bottom of the cell shaft.

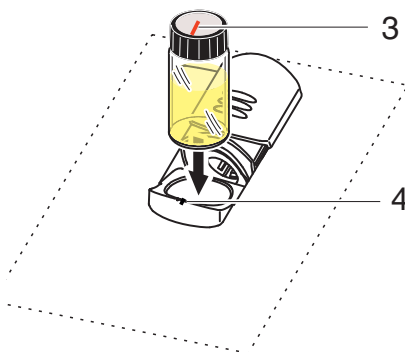

- 3 Align the cell marking (3) with the marking (4) of the cell shaft.  
The cell is ready to be measured.

### Preparing the cell and sample

#### Preparing the cell

Even completely clean quality cells exhibit tiny differences in their light transmittance, e.g. inhomogeneities of the glass or small defects (e.g. scratches). Therefore, guidelines for accurate and reproducible measurements (e.g. US EPA) recommend that you always align the cell in the same way for measuring with the aid of arrows printed on or markings. This refers to sample cells and cells for calibration standards.

Prior to using a cell for the first time, the suitable position of the cell in the cell shaft is determined and marked to make sure the optical path is not disturbed. For the following measurements, the cell marking can just be aligned with the meter marking.

The cell marking should be checked regularly and renewed as necessary. The cell can be used until no suitable position for the optical path can be found.



We recommend that you do not treat any scratches in the cell with oily liquids (not even with so-called "special silicone oils"). They could unnecessarily soil the meter and your working environment. The optimum measurement accuracy is ensured by aligning the cells. Scratched cells have to be replaced.

**Determining a suitable position in the cell shaft**

- 1 Clean the cell.
- 2 Stick the label for the marking onto the cell cap.
- 3 Fill the cell with a homogeneous solution (e.g. calibration standard 10.0 NTU).
- 4 Insert the cell.
- 5
  - Press and keep the **<START/ENTER (.) >** key depressed.
  - Turn the cell slowly and check the measured value:
    - The measured value at the position should be no minimum or maximum.
    - At the directly neighboring positions there should not be any sudden changes of the measured values. The deviations of measured values at the neighboring positions should not exceed the following values:  
 Measured value < 1 NTU: max. +/- 0.02 NTU  
 Measured value > 1 NTU: max. +/- 2 %
- 6 Release the **<START/ENTER (.) >** key.  
Measurement starts. The measured value is displayed.

**Marking a cell**

- 7 Mark the determined position (aligning) of the cell on the label.  
The cell is now prepared for all following measuring and calibration actions.

**Preparing the sample**

Air bubbles in the sample affect the measuring result to a massive extent because they have a large scattering effect on the incident light. Larger air bubbles cause sudden changes in the measured values whereas smaller air bubbles are recorded by the instrument as turbidity. Therefore, avoid or re-

### Avoiding or removing air bubbles

move air bubbles:

- During sampling, ensure all movement is kept to a minimum
- If necessary, vent the sample (ultrasonic baths, heating or adding a surface-active substance to reduce the surface tension)

### Measuring the turbidity

#### NOTE

**Never pour any liquids directly into the cell shaft. Always use a cell for measurement. The meter only measures precisely if the cell is closed with the black light protection cap and aligned with the marking of the measuring position determined.**



The outside of the cell always has to be clean, dry, and free of fingerprints and scratches. Clean the cells before starting to measure (see CLEANING THE CELLS, page 15). Only hold the cells by the top or by the black light protection cap.



With turbidity values under 1 FNU/NTU, the measured value is strongly influenced by the cell and its alignment.

To increase measurement accuracy with turbidity values under 1 FNU/NTU, calibration in the 0.02 FNU/NTU standard and later measurement should take place in the same cell.

### Measuring

For quick and easy measuring we recommend that you use marked cells.

If your cells are not marked you can determine the suitable position of the individual cells in the cell shaft while measuring.

- 1 Clean the cell (see CLEANING THE CELLS, page 15).
- 2 Rinse the cell:  
Pour approximately 10 ml sample into the cell. Close the cell and rotate it several times before throwing the sample away.
- 3 Repeat the rinsing procedure twice more.
- 4 Fill the cell with the sample to be measured (approx. 15 ml). Close the cell with the black light protection cap.
- 5 Insert the cell.
- 6 Align the marking on the cell cap with the marking at the cell shaft.  
or  
Determine the suitable position of the cell in the cell shaft.

- 7 Press the <**START/ENTER** (.) > key.  
Measurement starts. The measured value is displayed.

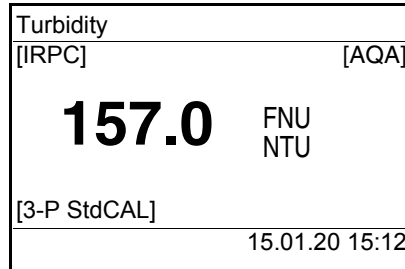

- 8 Repeat the steps 2 to 8 for further samples.

**Intelligent reproducibility and plausibility check (IRPC)**

With the intelligent reproducibility and plausibility check (IRPC) a multiple measurement is carried out, evaluated and, by eliminating the outliers, the plausible measured value is indicated on the display. The intelligent reproducibility and plausibility check (IRPC) is active with all measurements. It is displayed in the upper status line [IRPC].

**Calibration**

**When to calibrate?**

- Routinely within the framework of the company quality assurance
- When the calibration interval has expired
- With a temperature change

**Preparing the calibration**

For quick and easy measuring we recommend that you use marked cells with the calibration standards (see PREPARING THE CELL, page 9). If your cells are not marked you can determine the suitable position of the individual cells in the cell shaft while measuring. Perform the following preparatory activities when you want to calibrate:

- 1 Select the calibration type (menu *Configuration / Turbidity / Cal. type.*).



For *QuickCAL* calibration with the <**QuickCAL** <sup>(1)</sup> > key, the setting of the *QuickCAL* calibration type and limitation of the measuring range are done automatically.

- 2 Clean the cell (see CLEANING THE CELLS, page 15).
- 3 Insert the cell (see INSERTING A CELL, page 9).

**Carrying out a calibration (example: 3-P StdCAL)**

- 4 Press the **<CAL<sup>(4)</sup>>** key.  
The guided calibration with the selected calibration type starts.  
Follow the instructions on the display.

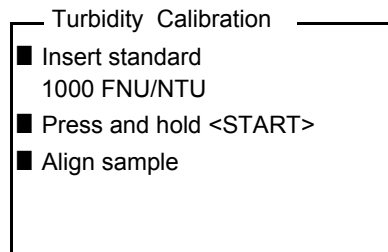

- 5 Insert the cell with the displayed calibration standard (here e.g. 1000 FNU/NTU) in the cell shaft.
- 6 Align the marking on the cell cap with the marking at the cell shaft.  
or  
Determine the suitable position of the cell in the cell shaft (see DETERMINING A SUITABLE POSITION IN THE CELL SHAFT, page 10).

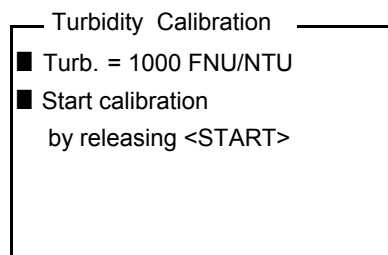

- 7 Release the **<START/ENTER<sup>(.)</sup>>** key.  
Measurement of the calibration standard begins.



Before measuring the third calibration standard of 0.02 FNU/NTU you can exit the calibration with **<ESC>** at any time.  
The new calibration data are discarded. The old calibration data are used.

- 8 Repeat the steps 4 - 6 with the calibration standards, 10.00 FNU/NTU and 0.02 FNU/NTU.  
After measuring the 0.02 FNU/NTU calibration standard, the calibration result is displayed.  
The calibration is complete.
- 9 Confirm the calibration result with **<START/ENTER<sup>(.)</sup>>**.  
The calibration record is displayed.

- 10 Confirm the calibration record with **<START/ENTER (.) >**.  
The display shows instructions for the first measurement.  
The valid calibration is indicated on the display as a status, e.g. [3-P StdCAL].

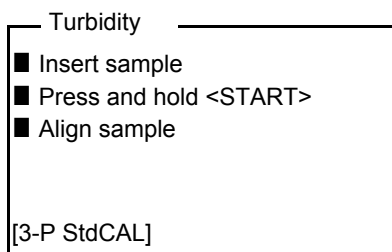

### Calibration record

At the end of each calibration procedure a calibration info (■ symbol) and the calibration record is displayed.

For each calibration type the last calibration is stored in the calibration memory.

## Maintenance, cleaning

### Maintenance

The meter is almost maintenance-free.

The only maintenance task is replacing the batteries.

### Inserting/exchanging the batteries

1. Open the battery compartment (1) on the underside of the meter.

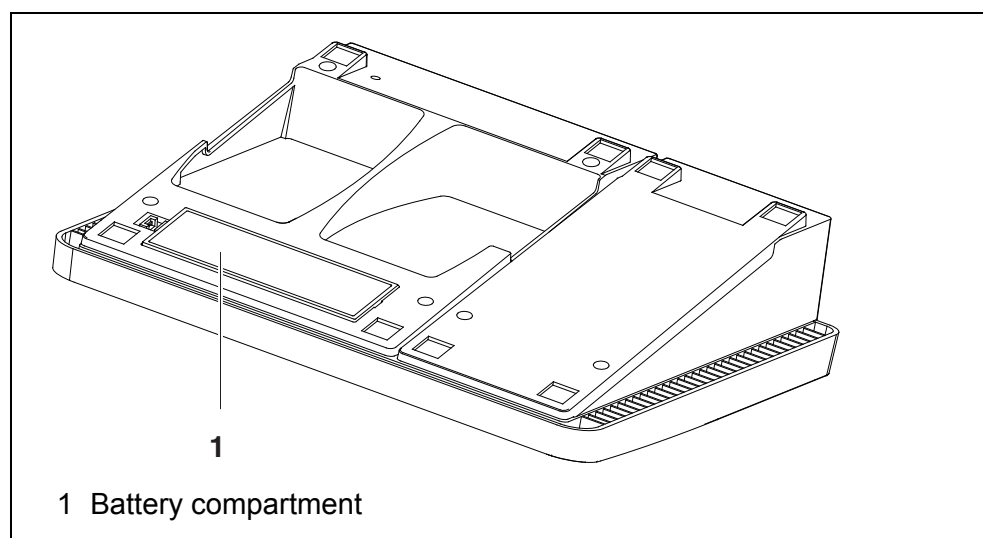

**NOTE**

**Make sure that the poles of the batteries are positioned correctly. The ± signs on the batteries must correspond to the ± signs in the battery compartment.**

- 11 Place four batteries (type Mignon AA) in the battery compartment.
- 12 Close the battery compartment (1).
- 13 Set the date and time  
(see SETTING THE DATE AND TIME, page 8).

**Cleaning**

Occasionally wipe the outside of the measuring instrument with a damp, lint-free cloth. Disinfect the housing with isopropanol as required.

**NOTE**

**The housing components are made of synthetic materials (polyurethane, ABS and PMMA). Thus, avoid contact with acetone and similar detergents that contain solvents. Remove any splashes immediately.**

**Cleaning the cell shaft**

If liquid is in the cell shaft (e.g. due to a spilled cell), clean the cell shaft as follows:

- 1 Switch the Turb<sup>®</sup> 750 IR/T off and pull out the power plug.
- 2 Rinse the cell shaft with distilled water.

**Cleaning the cells**

Cells have to be clean, dry, and free of fingerprints. Therefore, clean them regularly:

- 1 Clean the cells inside and out with hydrochloric acid or laboratory soap.
- 2 Rinse several times with distilled water.
- 3 Let them dry in the air.
- 4 Only hold the cells by the top or by the light protection cap so that the optical path is not impaired.
- 5 Before measuring, clean the cell with the enclosed cleaning cloth.



Scratches in the glass change the optical characteristics of the cell and falsify the measured value. For this reason, never use scratched cells!

## What to do if...

### General errors

#### Display, *LoBat*

Cause	Remedy
– Batteries almost empty	– Insert new batteries

#### Meter does not react to keystroke

Cause	Remedy
– Software error	– Processor reset: Press the <START/ENTER (.) > and <PRT <sup>(8)</sup> > key simultaneously.
– Operating condition undefined or EMC load unallowed	

#### Error message ■ *AQA not activated!*

Cause	Remedy
– The AQA function was not activated.	– Activate the AQA check

#### Error message, *Error 0, 8, 16, 16384*

Cause	Remedy
– Instrument error	– Repeat measurement
	– Meter defective, contact the service department

#### You want to know which software version is in the meter

Cause	Remedy
– E.g., a question by the service department	– Switch on the meter.
	– Open the menu <i>Configuration/ System/ Info</i> . The instrument data are displayed.

### Turbidity

#### Error message Measured values obviously incorrect

Cause	Remedy
– Cell not correctly inserted	– Lock cell into place
– Cell contaminated	– Clean the cell
– Calibration too old	– Carry out calibration



Measured value display < 0.01 FNU/NTU	Cause	Remedy
	– Calibration defective	– Carry out calibration
	– Measured value outside the measuring range	– Not possible

## Technical data

### General data

<b>Dimensions</b>	Approx. 290 x 190 x 80 mm	
<b>Weight</b>	Approx. 1.0 kg	
<b>Mechanical structure</b>	Type of protection	IP 43
<b>Electrical safety</b>	Protective class	III
<b>Test certificates</b>	CE	
<b>Ambient conditions</b>	Storage	-25 °C ... +65 °C
	Operation	+5 °C ... +55 °C With the power pack connected: +5 °C ... +40 °C
	Admissible relative humidity	Yearly mean: < 75 % 30 days/year: 95 % Other days: 85 %
<b>Power supply</b>	Batteries	4 x 1.5 V alkali-manganese batteries, type AA
	Power pack	ShenZhen RiHuiDa Power Supply Co Ltd RHD20W090150 Input: 100 ... 240 V ~ / 50 ... 60 Hz / 400 mA Output: 9 V = / 1.5 A Connection max. overvoltage category II
	Primary plugs	Primary plugs included in the scope of delivery: Euro, US, UK and Australian.

**Serial interface (printer)**

Connection of the cable AK 540/B or AK 540/S

Baud rate	Adjustable: 1200, 2400, 4800, 9600, 19200 Baud
Type	RS232
Data bits	8
Stop bits	1
Parity	None
Handshake	RTS/CTS
Cable length	Max. 15 m

**USB interface (PC)**

Type	USB 1.1 USB-B (Device), PC
Baud rate	Adjustable: 1200, 2400, 4800, 9600, 19200 baud
Data bits	8
Stop bits	1
Parity	None
Handshake	None
Cable length	max. 3 m (9.843 feet)

**Guidelines and norms used**

EMC	EC directive 2014/30/EC EN 61326-1 FCC Class A
Meter safety	EC directive 2014/35/EC EN 61010-1
IP protection class	EN 60529

### **FCC Class A Equipment Statement**

*Note:* This equipment has been tested and found to comply with the limits for a Class A digital device, pursuant to Part 15 of the FCC Rules. These limits are designed to provide reasonable protection against harmful interference when the equipment is operated in a commercial environment. This equipment generates, uses, and can radiate radio frequency energy and, if not installed and used in accordance with the instruction manual, may cause harmful interference to radio communications. Operation of this equipment in a residential area is likely to cause harmful interference in which case the user will be required to correct the interference at his own expense.

### **Turbidity (Turb<sup>®</sup> 750 IR)**

<b>Measuring principle</b>	Nephelometric measurement according to DIN EN ISO 7027		
<b>Light source</b>	Infrared LED		
<b>Calibration</b>	<b>3-P StdCAL</b>	<b>QuickCAL</b>	<b>FreeCAL</b>
<b>Measuring range depending on the calibration type</b>	0.01 ... 1100 FNU/NTU	0 - 40 FNU/NTU	lowest - highest standard FNU/NTU
<b>Resolution</b>	in the range 0.01 ... 9.99 FNU/NTU	max. 0.01 FNU/NTU	
	in the range 10.0 ... 99.9 FNU/NTU	max. 0.1 FNU/NTU	
	in the range 100 ... 1100 FNU/NTU	max. 1 FNU/NTU	
<b>Accuracy</b>	in the range 0 ... 1100 FNU/NTU	± 2 % of the measured value or ± 0.01 FNU/NTU	
<b>Repeatability</b>	0,5% of the measured value		
<b>Response time</b>	4 seconds		

### Turbidity (Turb® 750 T)

<b>Measuring principle</b>	Nephelometric measurement according to US EPA 180.1		
<b>Light source</b>	White light tungsten lamp		
<b>Calibration</b>	<b>3-P StdCAL</b>	<b>QuickCAL</b>	<b>FreeCAL</b>
<b>Measuring range depending on the calibration type</b>	0.01 ... 1100 NTU	0 - 40 NTU	lowest - highest standard NTU
<b>Resolution</b>	in the range 0.01 ... 9.99 NTU	max. 0.01 NTU	
	in the range 10.0 ... 99.9 NTU	max. 0.1 NTU	
	in the range 100 ... 1100 NTU	max. 1 NTU	
<b>Accuracy</b>	in the range 0 ... 500 NTU	± 2 % of the measured value or ± 0.01 NTU	
	in the range 500 ... 1100 NTU	± 3% of measured value	
<b>Repeatability</b>	1% of the measured value		
<b>Response time</b>	7 seconds		



# What can Xylem do for you?

We're a global team unified in a common purpose: creating innovative solutions to meet our world's water needs. Developing new technologies that will improve the way water is used, conserved, and re-used in the future is central to our work. We move, treat, analyze, and return water to the environment, and we help people use water efficiently, in their homes, buildings, factories and farms. In more than 150 countries, we have strong, long-standing relationships with customers who know us for our powerful combination of leading product brands and applications expertise, backed by a legacy of innovation.

**For more information on how Xylem can help you, go to [xylem.com](http://xylem.com).**



**Service address:**

Xylem Analytics Germany  
Sales GmbH & Co. KG  
WTW  
Dr.-Karl-Slevogt-Str. 1  
82362 Weilheim  
Germany

Tel.: +49 881 183-325  
Fax: +49 881 183-414  
E-Mail [wtw.rma@xylem.com](mailto:wtw.rma@xylem.com)  
Internet: [www.WTW.com](http://www.WTW.com)



Xylem Analytics Germany GmbH  
Dr.-Karl-Slevogt-Str. 1  
82362 Weilheim  
Germany