



Duo 125 , 三相电机 , 3TF , 220/380 V ,
60 Hz

Duo 125 , 三相电机 , 3TF , 220/380 V, 60 Hz



- 双级高性能旋转叶片泵且吸气能力至 135 m³/h
- 带 3 相电机
- 利用温度传感器（3TF）达到最佳的电机保护
- 集成型气镇阀和高压安全阀。
- 适于所有粗真空和中度真空范围的应用。
- 特点：通过不同的电动机电压可实现更广泛的使用
- 其他电动机电压的供货备询

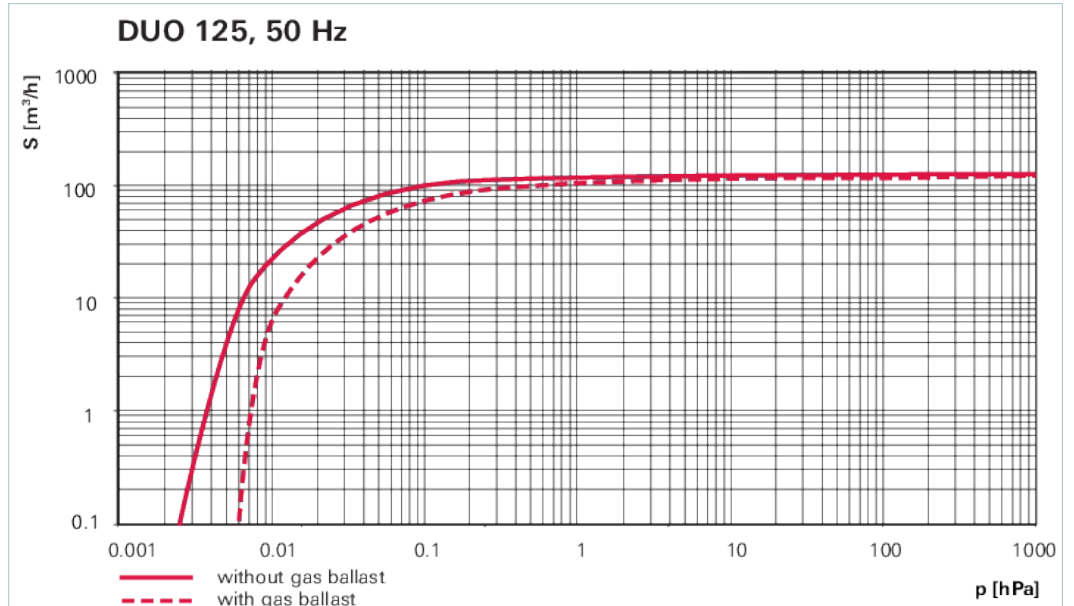
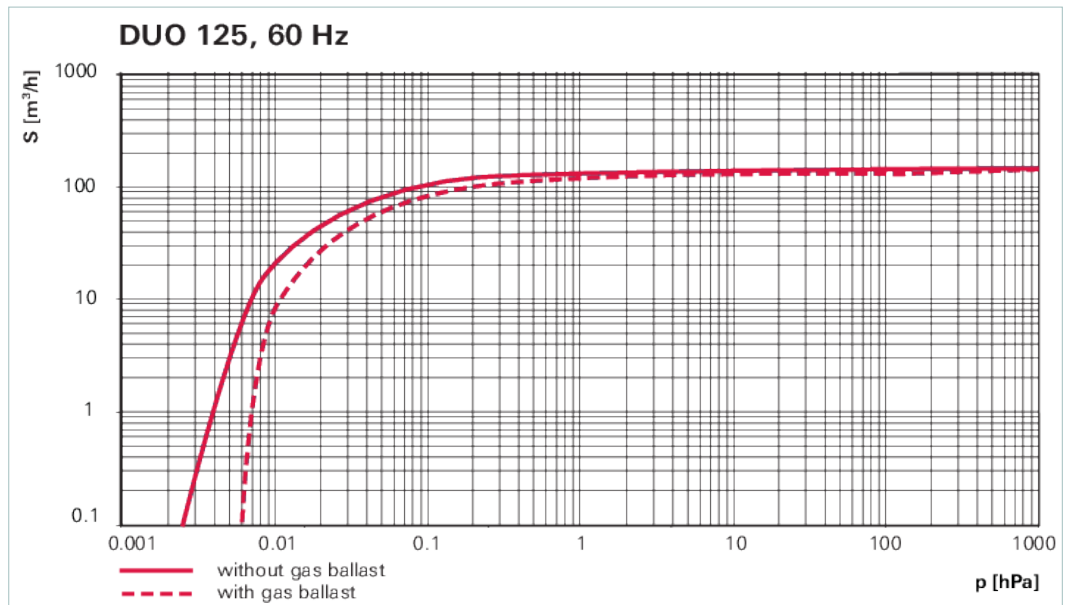

尺寸

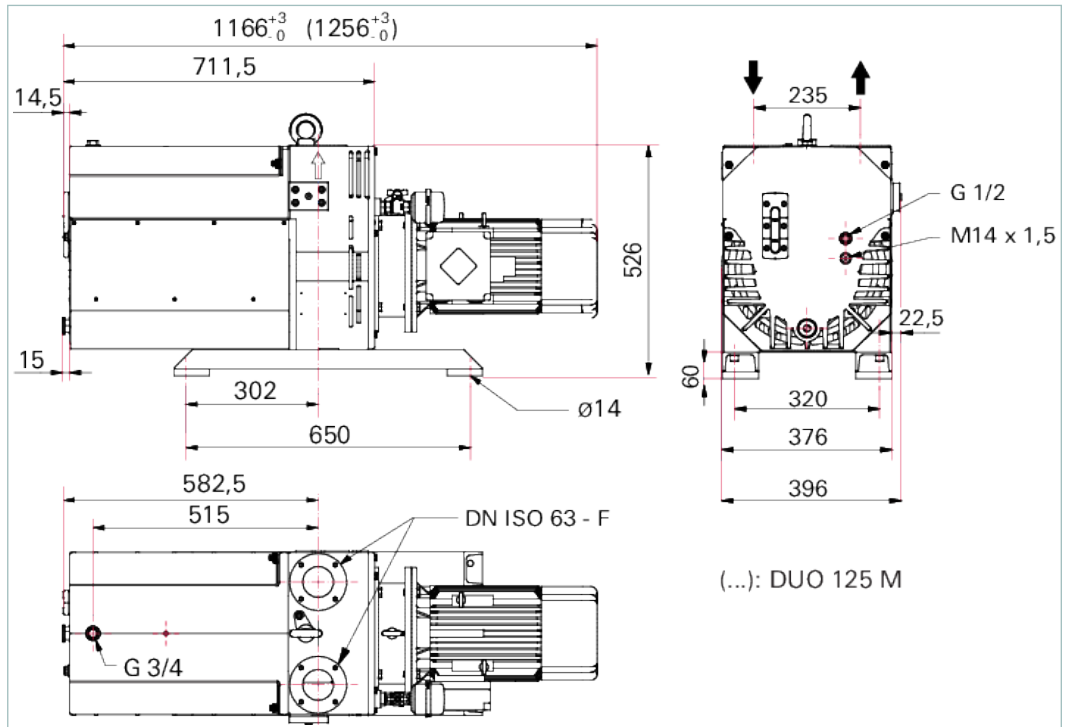

技术参数	Duo 125, 三相电机, 3TF, 220/380 V, 60 Hz
50 Hz 时不带气镇的声压级	75 (A)
60 Hz 时的抽速	140 m ³ /h
60 Hz 时的转速	1,200 rpm 1,200 min ⁻¹
不带气镇的最终压力	2 · 10 ⁻³
保护类型	IP55
冷却类型, 标准	
安全阀泄漏率	1 · 10 ⁻⁵ Pa m ³ /s
工作液	P3
工作液灌装	13
带气镇的最终压力	4 · 10 ⁻³
最大排气压力	1500
最小排气压力	250
环境温度	12 – 40
电机保护	3TF
电源连接:电压(范围)	±5 %
电源连接:电压 60 Hz	220/380 V
连接法兰(入口)	DN 63 ISO-F
连接法兰(出口)	DN 63 ISO-F
重量	245
额定功率 60 Hz	4

订单号	
Duo 125	PK D47 652

配件	
20-250 V AC	
油位监测 20-250 V AC, 用于 Okta 250/M Okta 300/M Okta 500/M Okta 600/M Okta 800/M Okta 1000/M Okta 2000/M Okta 4000/M Okta 6000/M, G 1 1/4	PK 004 930 -U
24 V DC	
油位监测 24 V DC, 用于 Okta 250/M Okta 300/M Okta 500/M Okta 600/M Okta 800/M Okta 1000/M Okta 2000/M Okta 4000/M Okta 6000/M, G 1 1/4	PK 005 639 -U
工作液液位监控	PK 006 001 -T
工作液的温度传感器	PK 006 040 -T
Duo 35/65、Duo 125/255 的操作监控单元 3	PK 223 739 AU
Duo 125/255 的油压开关	PK 223 806 -T
KAS 63, 冷凝分离器, 用于抽速最高 360 m ³ /h	PK Z10 010
OME M	
OME 63 M, 油雾过滤器, 用于抽速高达 135 m ³ /h	PK Z40 010
SAS 63, DN 63 ISO-K, 聚酯过滤器	PK Z60 511
KLF	
KLF 063, 冷阱	PK Z80 010
ZFO	
ZFO 063 的加热棒, 220 V, 50/60 Hz	PK Z90 030 A
回油装置, ODK 005, 标准版本	PK Z90 065
OFM 125, 机械油过滤器	PK Z90 340
D1 油, 20 l	PK 005 877 -T
D1 油, 5 l	PK 005 876 -T
D1 油, 1 l	PK 005 875 -T
OME C	
PK Z40 410	PK Z40 410
(PTC)	
PTC 电阻脱扣装置	P 4768 052 FQ
P3, 矿物油, 1 l	PK 001 106 -T
P3, 矿物油, 5 l	PK 001 107 -T
P3, 矿物油, 20 l	PK 001 108 -T

VACUUM SOLUTIONS FROM A SINGLE SOURCE

Pfeiffer Vacuum stands for innovative and custom vacuum solutions worldwide, technological perfection, competent advice and reliable service.

COMPLETE RANGE OF PRODUCTS

From a single component to complex systems:

We are the only supplier of vacuum technology that provides a complete product portfolio.

COMPETENCE IN THEORY AND PRACTICE

Benefit from our know-how and our portfolio of training opportunities!

We support you with your plant layout and provide first-class on-site service worldwide.

Are you looking for a
perfect vacuum solution?
Please contact us:

Pfeiffer Vacuum GmbH
Headquarters · Germany
T +49 6441 802-0
info@pfeiffer-vacuum.de

www.pfeiffer-vacuum.com

All data subject to change without prior notice.

PFEIFFER  **VACUUM**