

Lt29059H

High Resolution 29 Megapixel, USB 3.1 Gen 1 Camera
Ideal for applications such as: Traffic, Flat Panel Inspection, UAVs and Surveillance



High Resolution CCD Sensor with Global Shutter and NIR Enhancement

Lumenera's progressive scan Lt29059H digital camera is built for rugged 24/7 use. A proven high resolution 35 mm format CCD sensor with a fully global electronic shutter captures excellent quality images with zero blur. The KAI-29052 sensor doubles the NIR sensitivity of the KAI-29050 sensor, provides better sensitivity performance in the green (540nm) and red (620nm) wavelengths, and offers lower read noise. It also provides high smear rejection (-100 dB) and up to 64 dB linear dynamic range. Completely integrated Canon EF lens controller offers increased longevity and durability (no external cabling is required). The industrial-grade Lt29059H is ideally suited for applications requiring high resolution such as: intelligent traffic systems, high-resolution industrial inspection, surveillance and UAVs.

High Quality Images for Difficult Lighting Environments

The high quality CCD sensor provides both monochrome and vivid color images for the most demanding environments. Full streaming uncompressed video and still image captures are easily controlled through a set of stable and reliable USB 3.1 Gen 1 device drivers. Region of interest and binning modes enable the camera to run at faster frame rates by selecting a specific portion of an image and only transmitting that data. Image capture synchronization is achievable using either a hardware or software trigger and is complemented by 256 MB of on board memory for frame buffering to ensure image delivery.

Built for Reliability and Ease of Integration

The compact, light-weight design of the Lt29059H ensures easy integration into tight spaces and enclosures. The robust enclosure is designed to effectively dissipate heat and increase reliability by avoiding the need for a fan. The fully locking USB 3.1 Gen 1 cabling, power connector and digital interface ensure a simple plug-and-play installation. No framegrabber is required. Simplified I/O cabling is provided through a 12 pin GPIO connector supporting 1 output, 1 input and 2 software configurable I/O ports.

Maximize Camera Performance Within Your Own Application

The Lumenera Camera SDK provides a full suite of features and functions that allow you to maximize the camera's performance within your own vision application. The SDK is compatible with all of our USB and GigE-based cameras and includes over 50 sample applications. Microsoft DirectX/DirectShow, Windows API and .NET API interfaces are provided, allowing you the choice of application development environments from C/C++ to VB.NET or C#.NET. Full inline IntelliSense autocompletion is provided with the .NET API interface and is accompanied by a full API manual describing all camera functions and properties.

Superior Technical Assistance Center

All Lumenera cameras are supported by an experienced team of imaging experts for pre-sale and post-sale technical support. We understand your imaging needs and are here to help you get the most out of your camera.

Features

- Canon EF lens mount with fully integrated controller for auto focus/iris supported by Lumenera's API, increases accuracy and flexibility for remote applications
- Compact form factor measuring 76.2 x 76.2 x 82.6 mm for easy integration, without losing the image quality typical in larger sized cameras
- High quality ON Semiconductor Truesense KAI-29052 CCD sensor provides excellent dynamic range and color reproduction
- Fanless body, small footprint and lower power requirements
- Color or monochrome, interline transfer, progressive scan 29 MP CCD sensor
- USB3 Vision Compliant
- Locking industrial USB 3.1 Gen 1 interface
- 1 output, 1 input and 2 software configurable I/O ports via GPIO connector for control of peripherals and synchronization of lighting
- 256 MB RAM frame buffer
- Simplified cabling - video, and full camera control over a single USB cable
- 8 mounting points and 2 tripod (1/4"-20) mounts
- Binning improves sensitivity and Region of Interest (ROI) provides higher frame rates
- FCC Class B, CE Certified
- Select 8 or 14-bit pixel data
- DirectX/DirectShow compatible
- Software compatible with Windows 10, Windows 8.1, Windows 7, Linux, 32 and 64-bit operating systems
- Complete SDK available
- Four (4) year warranty



Color Quantum Efficiency Curve

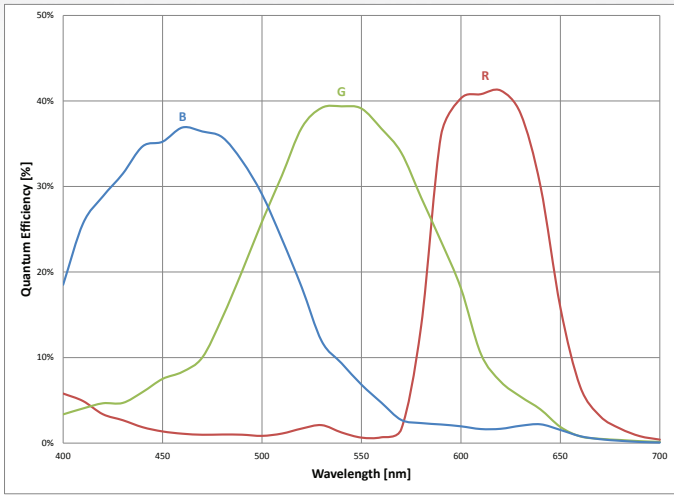

Monochrome Quantum Efficiency Curve

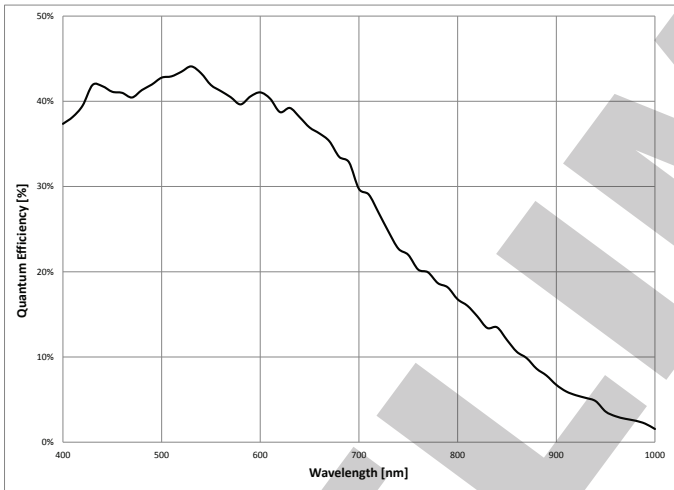

Customization Options

-WOIR	AR/AR glass within lens mount
-WOG	Without any glass within lens mount
-CC	Conformal Coating

Sensor Specifications	
Image Sensor	Truesense KAI-29052, CCD, color, monochrome
Optical Format	35 mm
Imager Size	Diagonal 43.47 mm
Pixel Size	5.5 x 5.5 μm
Resolution	6576 x 4384 pixels
Region of Interest Control	Yes
Camera Specifications	
Frame Rate	~6 fps at full resolution, faster with ROI
Bit Depth	8 or 14-bit
Binning	2x2, 4x4, 8x8
Electronic Shutter	Global
Exposure Control	Manual and automatic control
Exposure Range	Video mode: ~21 μs to 780 ms (4-tap) / 950 ms (2-tap) / 1750 ms (1-tap) (video) Snapshot mode: ~35 μs to 71 minutes (snapshot)
Gain Control	Manual and automatic control
Gain Range	~0.6 to ~43
White Balance	Manual and automatic control
Trigger Modes	Hardware and software triggerable
Camera Characteristics	
Sensitivity (8-bit)	Mono: 4.9 DN/(nJ/cm ²), Color: 4.8 DN/(nJ/cm ²) (Global and channel gains at unity)
Dynamic Range	~62.5dB
Full Well Capacity	~15,000 e-
Quantum Efficiency	41%@ 620nm peak color), 44%@ 530nm (mono)
Read Noise	~11 e-
Nominal Dark Current (Sensor Temp. @40C)	Photodiode: 7 [e-/pixel/sec] VCCD: 140 [e-/pixel/sec]
Mechanical Specifications	
Data Interface	USB 3.0, locking connector
General Purpose I/O	Locking Hirose HR10A-10R-12PB(71)
Lens Mount	Canon EF mount (focus/iris support). Supports other mounts with 3rd party adapter rings
Dimensions	76.2 x 76.2 x 82.6 mm 3.0 x 3.0 x 3.25 inch
Mass	~600 g
Operating Temperature	0 to 50 °C (Requires recommended heat sinking to external enclosure)
Storage Temperature	-30 to 70 °C
Operating Humidity	5 to 95 %, non-condensing
Shock / Vibration	50 g shock, 5 g (2 to 200 Hz) vibration
Onboard Memory	Camera has onboard non-volatile memory storage
Camera Software	
Operating Systems	Windows 10, Windows 8.1, Windows 7, Linux, 32 and 64-bit operating systems
Software Interfaces	Windows API, .NET, DirectX/DirectShow, USB3 Vision
Power and Emissions	
Power Consumption	~13 W (average)
Power Requirement	12V DC via DC connector or GPI/O
Emissions Compliances	FCC Class B, CE Certified
Hazardous Materials	RoHS, WEEE Compliant
Warranty	Four (4) year
Ordering Options	
Lt29059HM	29MP NIR Mono Camera, La120315 12V DC Power supply
Lt29059HC	29MP NIR Color Camera, La120315 12V DC Power supply
La120315	Locking 12V DC international power supply
La303L	USB 3.0 Cable (3m / 9.75 ft, A Male to B Male Locking)



Mechanical Drawings

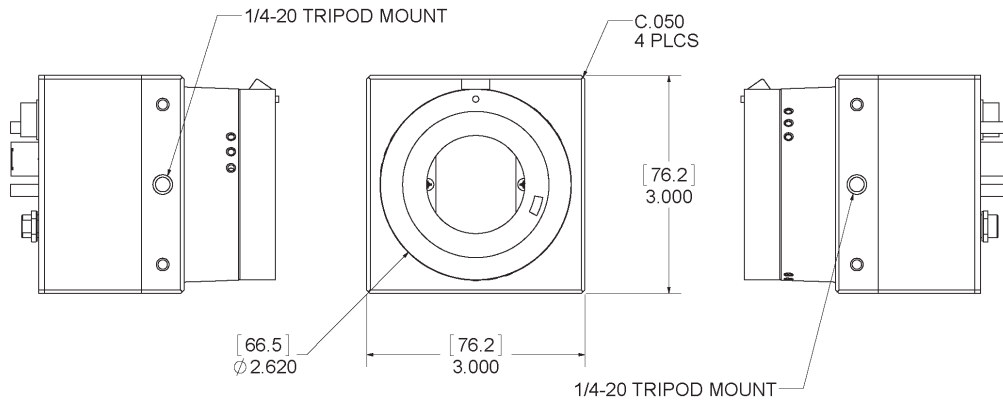
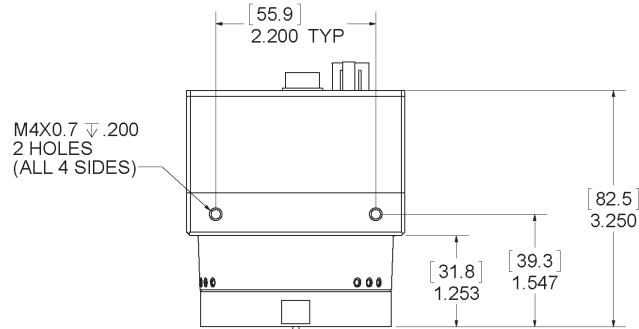
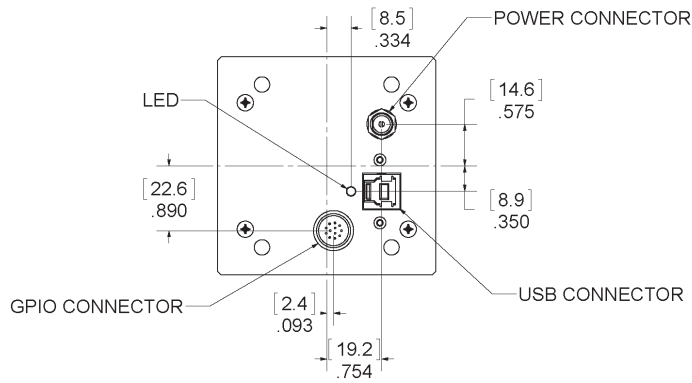
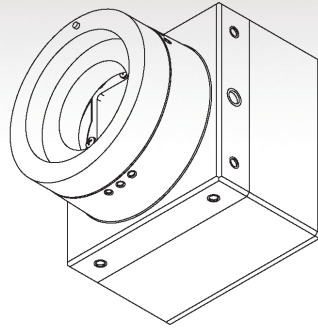

Measurements = inch

