

SSIVT CURRENT VOLTAGE MEASUREMENT

IV Measurement Instruments for Advanced Characterization



Features

- Features industry standard Keithley 2400 **series SMU's**
- Available for continuous or flash operation
- Expandable power range with Sciencetech proprietary LoadBoost technology
- Calculates all critical cell performance parameters
- Easy-to-use software interface
- Remote operation of Sciencetech flash systems
- Works with all Sciencetech Solar Simulators

Applications

- IV test and photovoltaic cell performance characterization
- Test applications that demand tightly coupled sourcing and measurement
- Providing precise voltage and current sourcing as well as measurement capabilities

努美(北京)科技有限公司
北京市石景山区石景山路乙18号
万达广场C座1307室
Tel: 010-62362608
Email: sales@nmerry.com
Web: www.nmerry.com



SSIIVT CURRENT VOLTAGE MEASUREMENT

Overview

The Sciencetech model SSIIVT is an electrical current voltage measurement system that uses a Keithley 2400 series sourcemeter to characterize photovoltaic cell performance. Sciencetech manufactures Solar Simulators and offers a variety of cell measurement accessories such as reference cells, cell chucks and cooling equipment to provide the full PV measurement package.

Coupled with Sciencetech's Load Booster system Sciencetech offers industry leading power range. Our maximum measurable panel is up to 200V, 80A. See the BI series modules information below.

Sciencetech's SSIIVT systems can be combined with our wide range of flash and continuous solar simulators and accessories to create a customized modular system to meet your exact needs.

Modular measurement systems

Sample test system:

- 150W Fully Reflective Solar Simulator (160-9001)
- Downward Facing Vertical Stand for SS150 (160-9013)
- Current-Voltage Measurement System - 20W Version for Continuous Solar Simulator (175-9103)
- Calibrated Reference Cell, Quartz Window (590-0154)
- 16.5x16.5cm Solar Cell Chuck, Liquid Cooled, Vacuum Ready (165-8204)
- Water Recirculating Cooler 500W Capacity (165-8021)
- Probe Station, 4 Probes, Tungsten Needle-tip Kelvin Probes (165-8211)

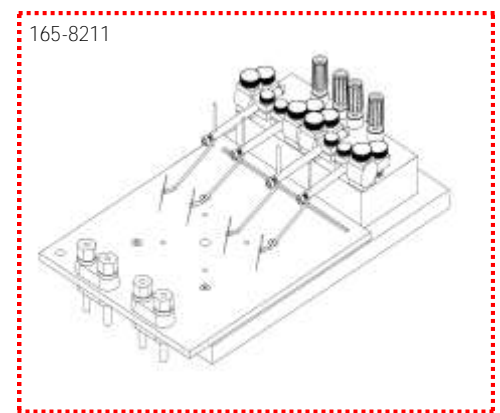
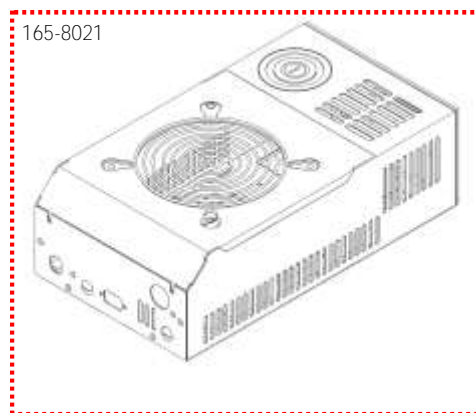
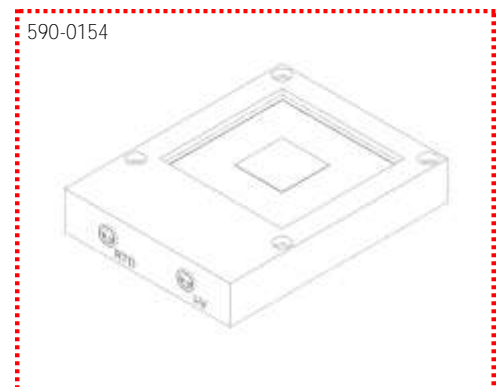
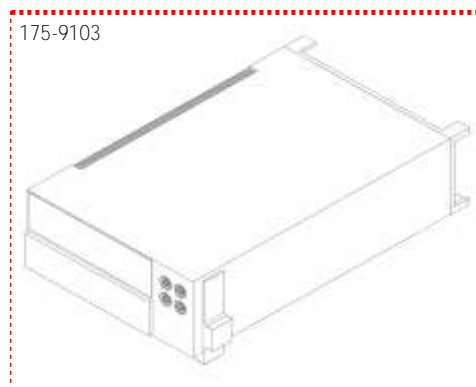
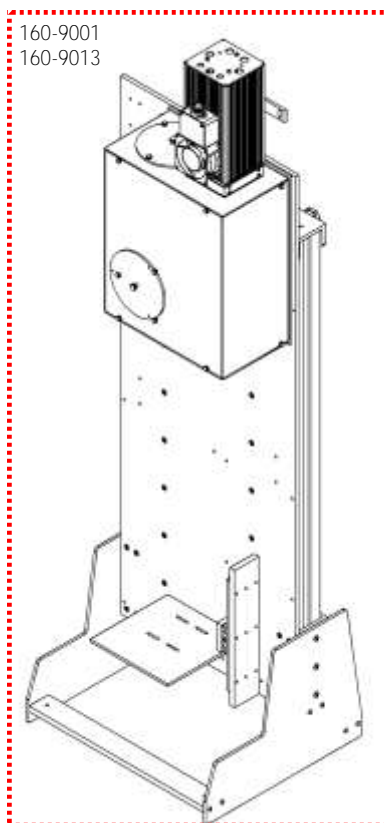

SSIVT CURRENT VOLTAGE MEASUREMENT

Specifications

SSIVT for Continuous Illumination

Model	SSIVT-21C	SSIVT-20C	SSIVT-60C	SSIVT-T20C	SSIVT-2KC
Part No.	175-9106	175-9103	175-9101	175-9108	175-9107
Measured Quantities	Voc, Isc, Vmax, Imax, Pmax, FF, Rseries, Rshunt				
PV Voltage Range	0 - 20V	0 - 200V	0 - 60V	0-200V	0-200V
Current Range	0 - 1A	0 - 1A	0 - 3A	1A	10A
Power Range	0 - 20W	0 - 20W	0 - 60W	0-20W	0-2000W
Running Mode	Continuous				
Source Measure Unit (SMU) Model	Keithley 2401	Keithley 2400	Keithley 2420	Keithley 2450	Keithley 2400
Touchscreen	NO	NO	NO	YES	NO
LoadBoost Module	None				BI100
Expandable Range with LoadBooster Add-ON	NO	YES	NO	YES	YES
Voltage Source Accuracy at Maximum Voltage (1 Year, 23°C ± 5°C)	0.02% + 2.4mV	0.02% + 24mV	0.02% + 7.2mV	0.015% +24mV	0.02% + 24mV
Voltage Programming Resolution at Maximum Voltage	500µV	5mV	1.5mV	5mV	5mV
Current Measurement Accuracy at Maximum Current (1 Year, 23°C ± 5°C)	0.22% + 570µA	0.22% + 570µA	0.052% + 1.71mA	0.03%+500uA	0.22% + 57mA
Connection	4-wire (Remote) Measurement (In/Out + Sense +/-)				
# of Data Points / Scan*	2 - 100				
Scan time*	2 - 50s for steady-state illumination				
Operating System Compatibility	Windows 7 32-bit				

SSIVT for Pulsed Illumination

Model	SSIVT-20F	SSIVT-60F	SSIVT-2kF
Part No.	175-9104	175--9102	175-9100
Measured Quantities	Voc, Isc, Vmax, Imax, Pmax, FF, Rseries, Rshunt		
PV Voltage Range	0 - 20V	0 - 200V	0 - 60V
Current Range	0 - 1A	0 - 1A	0 - 3A
Power Range	0 - 20W	0 - 20W	0 - 60W
Running Mode	Pulsed		
Source Measure Unit (SMU) Model	Keithley 2400	Keithley 2400	Keithley 2420
Touchscreen	NO	NO	NO
LoadBoost Module	None		BI100
Expandable Range with LoadBooster Add-ON	YES	NO	YES
Voltage Source Accuracy at Maximum Voltage (1 Year, 23°C ± 5°C)	0.02% + 24mV	0.02% + 7.2mV	0.02% + 24mV
Voltage Programming Resolution at Maximum Voltage	5mV	1.5mV	5mV
Current Measurement Accuracy at Maximum Current (1 Year, 23°C ± 5°C)	0.22% + 570µA	0.052% + 1.71mA	0.22% + 57mA
Connection	4-wire (Remote) Measurement (In/Out + Sense +/-)		
# of Data Points / Scan*	2 - 100		
Scan time*	10s-10min for pulsed illumination		
Operating System Compatibility	Windows 7 32-bit		

SSIVT CURRENT VOLTAGE MEASUREMENT

Expandability

Sciencetech's SSIVT-20C and SSIVT-20F systems can be coupled with a Sciencetech load booster system (as shown in the figure on the right) to allow for much higher power measurements. The load booster is inserted between the Keithley and the device under test. The BI100, for example, allows us to measure up to 10A up to the full 200V range of the Keithley.

The load booster can be used in both AC and DC measurements. Not compatible with SSIVT-21C, SSIVT-60C, or SSIVT-60F systems

Load booster systems

Model	Voltage	Current
BI100 (166-9001)	200V	10A
BI200 (166-9010)	200V	20A
BI400 (166-9011)	200V	40A
BI600 (166-9012)	200V	60A
BI800 (166-9013)	200V	80A



SSIIVT CURRENT VOLTAGE MEASUREMENT

SSIIVT system configuration

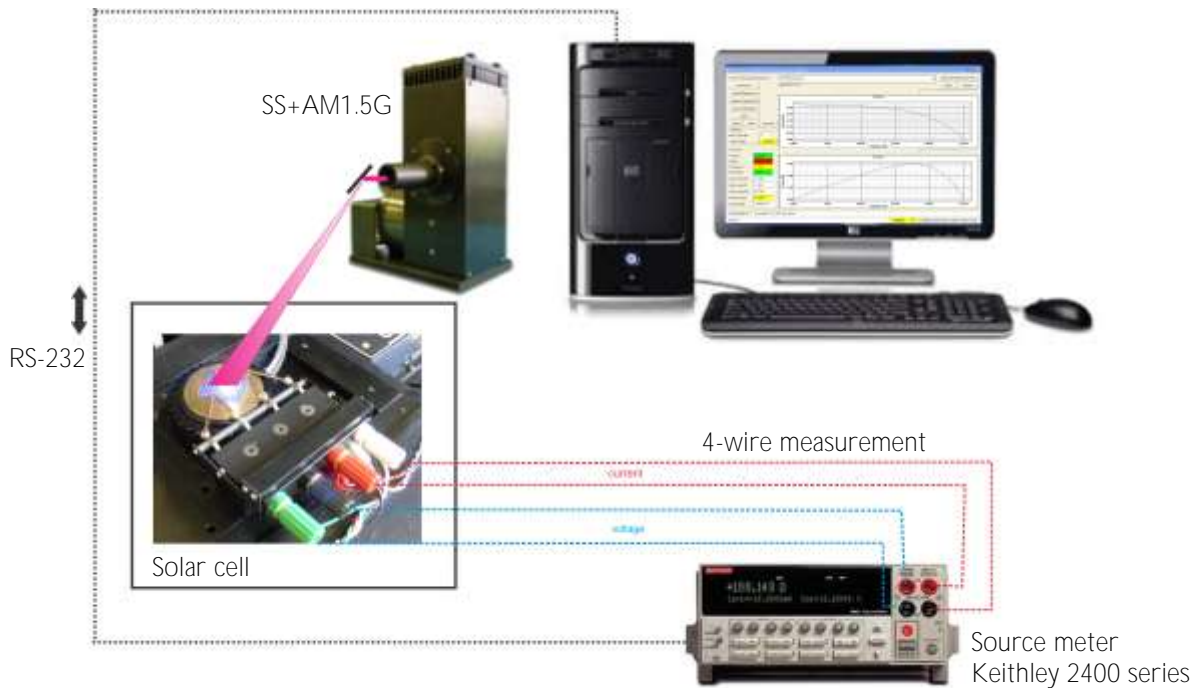

SciRunIV Software (SOFT-0102)

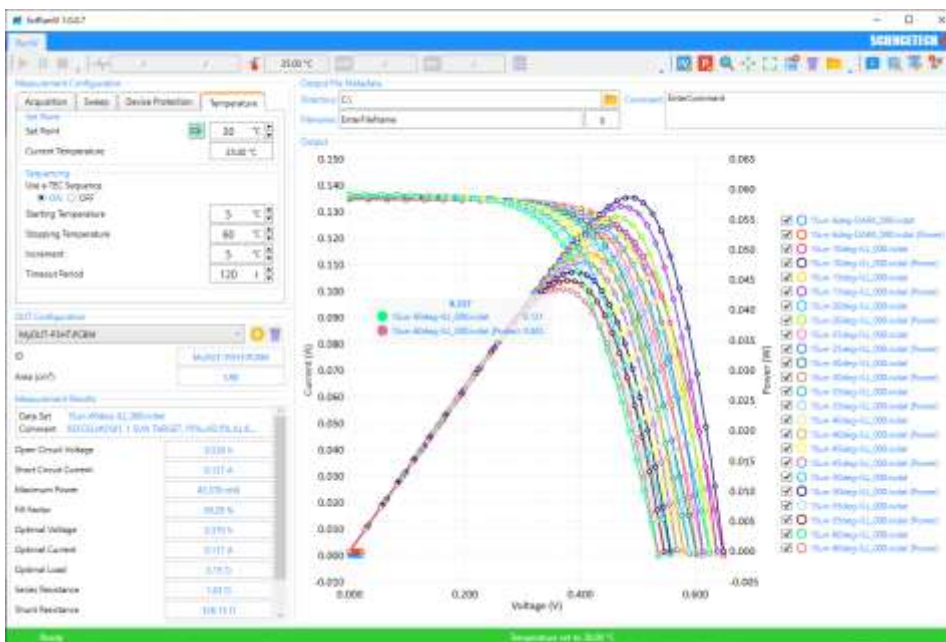

Software features:

- Light and dark IV measurements
- Displays reference data
- Manual or automatic range selection
- Allows user calibration of reference detectors
- Graphs Current Vs. Voltage and Power Vs. Voltage
- Overlay Curves for comparison
- Measures V_{OC} , I_{SC} , V_{max} , I_{max} , P_{max} , FF , R_{series} and R_{shunt}
- Outputs data to text files readable by all major data analysis software
- Curve smoothing function
- Configurable limit tests to assess cell quality
- Linear and non-linear step voltage
- Records number of flashes for flash systems.
- Temperature logging (optional)
- Point-by-point Irradiance and temperature measurements (optional)
- Cell efficiency calculation (optional)

SSIVT CURRENT VOLTAGE MEASUREMENT

Upgrades of Hardware and Software

	Name	Description
175-9050	IV Test / PTS Temperature Measurement Upgrade	<p>This is a modification to the Keithley unit used for IV Test measurements to allow the system to measure temperature at the same time as intensity. These Keithley units are used in all of Sciencetech's line of Photovoltaic Testing Systems, as well as our stand-alone IV Test units.</p> <p>Please note that this system requires a calibrated reference cell to operate, and will not function with flash illumination systems.</p>
175-9105	(SSIVT-TU) Point-by-Point Irradiance and Temperature Measurement Upgrade for IV Testers	<p>This upgrade adds the necessary hardware and software modifications to Sciencetech's SSIVT line of IV Testers to allow real-time measurement of temperature, irradiance, and calculations of thermal coefficients for each point of the IV curve.</p> <p>Please note that this upgrade requires a Sciencetech IV Tester in order to function, and will not work if a 3rd party tester is purchased from a different supplier.</p> <p>Please speak with your authorized Sciencetech technical support staff member to discuss specifications and any additional details required.</p>

Preconfigured host PC (490-0402)

Pre-configured, Out of the Box

We supply a new mid-grade Personal Computer with a flat screen monitor using licensed Windows Software pre-installed with all drivers.

Not "Just a Computer"

When you purchase a pre-configured host PC from Sciencetech with any Sciencetech equipment, every aspect of the system is tested to ensure smooth operation. With complex systems it can be difficult to select the correct computer and avoid incompatibilities so let us provide a fully tested and operational PC for you. We provide all drivers, hardware, software, cables, etc. needed to get the system up and running.

System requirements

- Windows 7 Operating system, 32-Bit only (Compatible with Windows XP / Vista)
- REQUIRES Hardware Serial Port on Computer Motherboard
- Intel Core i3 processor or better
- At least 1GB RAM
- Optical Drive
- Screen resolution



F. Dimensions and Weight

Dimensions

89mm high × 213mm wide × 370mm deep (3 1/2 in × 8 3/8 in × 14 9/16 in)

Bench configuration (with handle & feet)

104mm high × 238mm wide × 370mm deep (4 1/8 in × 9 3/8 in × 14 9/16 in)

Weight

3.21kg (7.08 lbs.)

努美(北京)科技有限公司

北京市石景山区石景山路乙18号

万达广场C座1307室

Tel: 010-62362608

Email: sales@nmerry.com

Web: www.nmerry.com