

Imager *M-lite* 2M

small, light weight CMOS camera with USB 3.0 interface for distances up to 25 m



The **Imager *M-lite* 2M** is a high sensitivity, high resolution digital camera, equipped with the new generation CMOS sensors with excellent image quality and low readout noise. The camera delivers true 12 bit digital images and comes with USB 3.0 interface for distances up to 25 m. The resolution of 2.3 Megapixel at 100 Hz frame rate in combination with its small and lightweight design makes this camera ideal for flexible use in highly ambitious applications in scientific as well as industrial fields.

General System Specifications

Exposure time	34 μ s - 10 s
Digital output	12 bit, 8 bit
Interface	USB 3.0 cable to camera, 5 meter length
Lens mount	CS-mount, adapter to C-mount and F-mount included
Number of pixels	1936 x 1216 pixels
Pixel size	5,86 x 5,86 μ m ²
Full well capacity	32,000 e ⁻
Max. QE	72% @ 500 nm
Frame rate	100 frames/s @ 12 bit or 155 frames/s @ 8 bit using the recommended USB3 interface card
Noise	7 e ⁻

Operating temperature	0 – 40 °C
Size of camera head (L x W x H)	48.2 mm x 47 mm x 47 mm
Weight	175 g
Power requirements	3.4 W via USB 3.0 interface

Requirements	DaVis Software / PC / timing unit / Windows 7 or 10 (64 bit) or StrainMaster DIC Software StrainMaster Controller or Device Control Unit X PC / Windows 7 or 10 (64 bit)
---------------------	---

Quantum efficiency

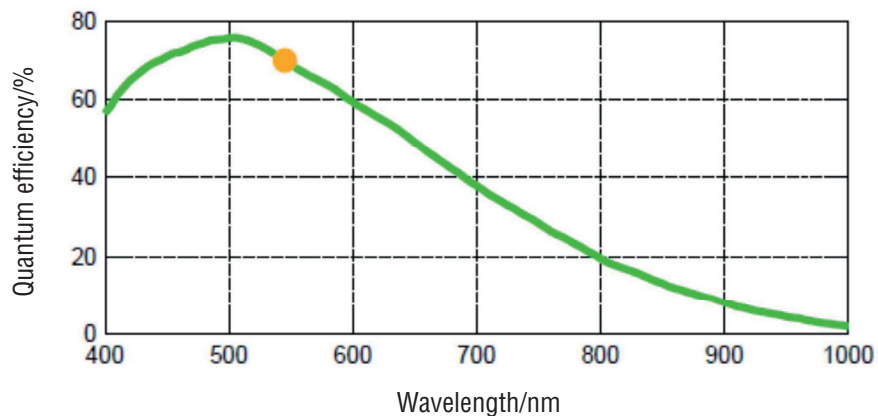

LaVisionUK Ltd

2 Minton Place / Victoria Road
Bicester, Oxon / OX26 6QB / United Kingdom
E-mail: sales@lavision.com / www.lavisionuk.com
Phone: +44-(0)-870-997-6532 / Fax: +44-(0)-870-762-6252

LaVision GmbH

Anna-Vandenhoeck-Ring 19
D-37081 Göttingen / Germany
E-mail: info@lavision.com / www.lavision.com
Tel. +49-(0)551-9004-0 / Fax +49-(0)551-9004-100

LaVision Inc.

211 W. Michigan Ave. / Suite 100
Ypsilanti, MI 48197 / USA
E-Mail: sales@lavisioninc.com / www.lavisioninc.com
Phone: (734) 485 - 0913 / Fax: (240) 465 - 4306

Dimensions

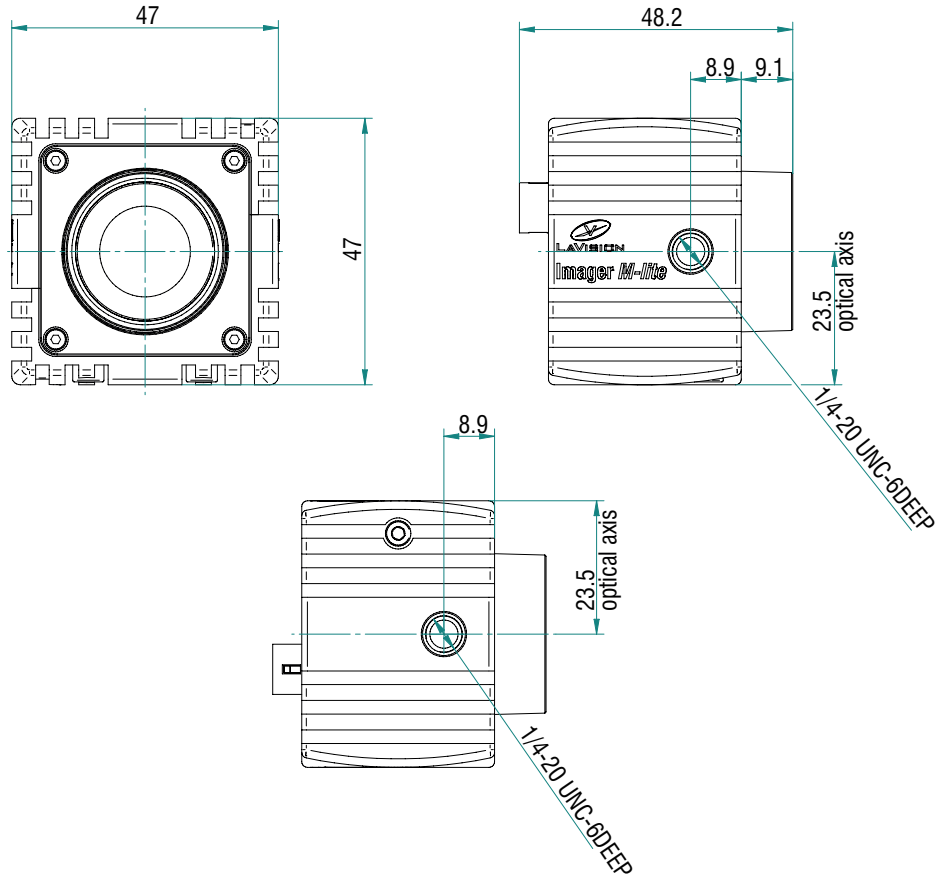

Data provided by LaVision are believed to be true. However, no responsibility is assumed for possible inaccuracies or omissions. All data are subject to change without notice.

Jan-19

Ordering information

Part number	Description
1101501	Imager <i>M-lite</i> 2M camera
1009823	USB 3.0 interface card to connect up to 4 cameras
1012197	USB 3.0 extension cable 10 meter
1009887	USB 3.0 extension cable 20 meter

LaVisionUK Ltd

2 Minton Place / Victoria Road
Bicester, Oxon / OX26 6QB / United Kingdom
E-mail: sales@lvision.com / www.lvisionuk.com
Phone: +44-(0)-870-997-6532 / Fax: +44-(0)-870-762-6252

LaVision GmbH

Anna-Vandenhoeck-Ring 19
D-37081 Göttingen / Germany
E-mail: info@lvision.com / www.lvision.com
Tel. +49-(0)551-9004-0 / Fax +49-(0)551-9004-100

LaVision Inc.

211 W. Michigan Ave. / Suite 100
Ypsilanti, MI 48197 / USA
E-Mail: sales@lvisioninc.com / www.lvisioninc.com
Phone: (734) 485 - 0913 / Fax: (240) 465 - 4306