

Imager *sCMOS*

scientific imaging
breakthrough



LaVision's **Imager *sCMOS*** camera overcomes traditional trade-offs of current camera technology standards and offers outstanding imaging performance in the field of quantitative scientific (laser) imaging.

The **Imager *sCMOS*** camera is especially designed for the demanding requirements in laser imaging applications such as Particle Image Velocimetry (PIV) and Planar Laser Induced Fluorescence (PLIF): low light imaging combined with large signal variations, highest temporal and spatial resolution over large fields of view illuminated by the laser sheet.

Data storage with full camera rate of 50 fps is possible to the PC RAM allowing long recording sequences only limited by the RAM size. The outstanding min. interframing time of 120 ns makes this camera ideal for all kind of PIV applications.

General System Specifications

Double shutter	two images with 120 ns interframing time
Exposure time	15 μ s - 100 ms
Digital output	16 bit
Interface	Frame grabber CLHS optical for PCIe 4 x slot, to be ordered separately
Lens mount	F-mount (optional C-mount)
Number of pixels	2560 x 2160 pixels
Pixel size	6.5 μ m x 6.5 μ m
Active area	16.6 mm x 14.0 mm
Spectral range	370 – 1100 nm
Quantum efficiency	typ. 53 % @ 532 nm
Full well capacity	30,000 e ⁻
Readout noise	< 3 e ⁻ @ 286 MHz
Frame rate	50 fps

Area of interest adjustable, centered AOI

Examples

Resolution	Frame rate
2560 x 2160	50 fps
1920 x 1080	100 fps
1600 x 1200	90 fps

Operating temperature	10 – 40 °C
Dimensions (LxWxH)	103 mm x 80 mm x 86 mm
Weight	700 g

Requirements DaVis 10 Software / PC / PTU X / Windows 10 (64 bit)

LaVisionUK Ltd

2 Minton Place / Victoria Road
Bicester, Oxon / OX26 6QB / United Kingdom
E-mail: sales@lvision.com / www.lvisionuk.com
Phone: +44-(0)-870-997-6532 / Fax: +44-(0)-870-762-6252

LaVision GmbH

Anna-Vandenhoeck-Ring 19
D-37081 Göttingen / Germany
E-mail: info@lvision.com / www.lvision.com
Tel. +49-(0)551-9004-0 / Fax +49-(0)551-9004-100

LaVision Inc.

211 W. Michigan Ave. / Suite 100
Ypsilanti, MI 48197 / USA
E-mail: sales@lvisioninc.com / www.lvisioninc.com
Phone: (734) 485 - 0913 / Fax: (240) 465 - 4306

Quantum efficiency

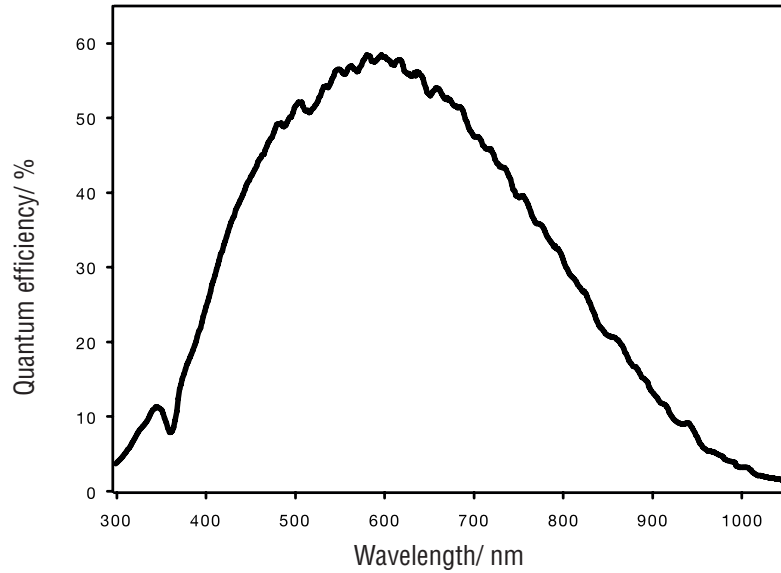

Dimensions

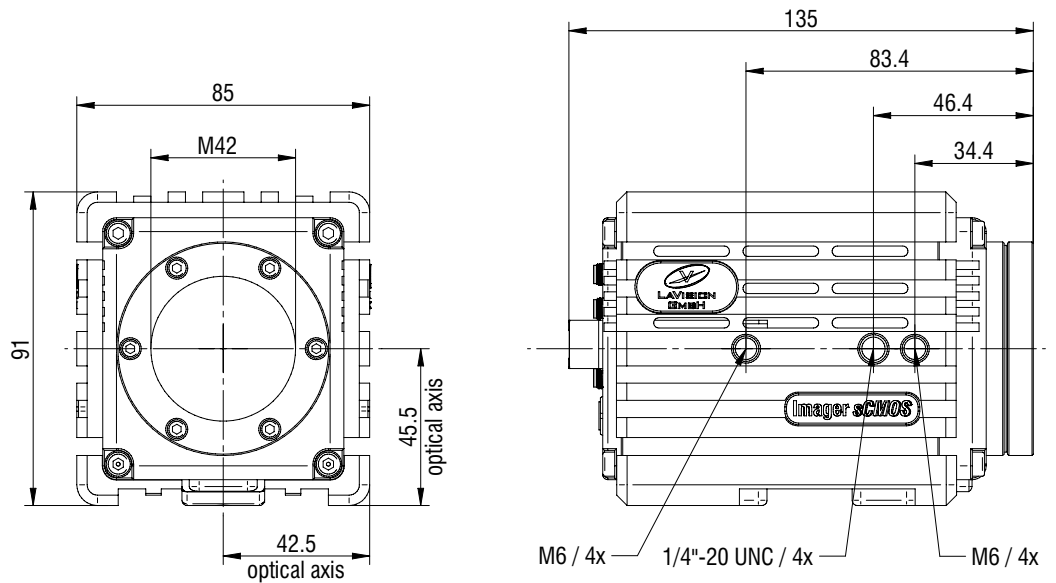

all dimensions shown in mm

Ordering information

Part number	Description
1101407	Imager sCMOS camera (10 m FOL cable included)
1101409	Frame grabber CLHS, for up to 2 cameras

Data provided by LaVision are believed to be true. However, no responsibility is assumed for possible inaccuracies or omissions. All data are subject to change without notice.

Mar-18

LaVisionUK Ltd

2 Minton Place / Victoria Road
Bicester, Oxon / OX26 6QB / United Kingdom
E-mail: sales@lvision.com / www.lvisionuk.com
Phone: +44-(0)-870-997-6532 / Fax: +44-(0)-870-762-6252

LaVision GmbH

Anna-Vandenhoeck-Ring 19
D-37081 Göttingen / Germany
E-mail: info@lvision.com / www.lvision.com
Tel. +49-(0)551-9004-0 / Fax +49-(0)551-9004-100

LaVision Inc.

211 W. Michigan Ave. / Suite 100
Ypsilanti, MI 48197 / USA
E-mail: sales@lvisioninc.com / www.lvisioninc.com
Phone: (734) 485 - 0913 / Fax: (240) 465 - 4306