



## C13398 series

### Absorbance measurement module with built-in photodiode array, optical elements, current-to-voltage converter, etc.

The C13398 series is an optics module for absorbance measurement featuring high blocking performance ( $OD > 4$ ) and low noise. It is composed of Si photodiodes, beam splitters, filters, and current-to-voltage conversion circuit. The C13398-01 can detect 10 wavelengths of light simultaneously. The C13398-02 can detect 9 wavelengths of light and a reference light simultaneously. In combination with the dedicated evaluation circuit C13390 (sold separately), the analog output signals of each channel of the C13398 series can be converted into digital signals, and the results can be acquired into the PC.

#### Features

- Simultaneous detection of 10 wavelengths
- High blocking characteristics:  $OD > 4$
- Voltage output: Easy handling
- Compact: 38 (W) × 89 (D) × 26 (H) mm (2/3 the business card size)
- Can be mounted on optical rod (M4)

#### Applications

- Blood analysis device
- Absorbance analyzer

#### Absolute maximum ratings ( $T_a = 25\text{ °C}$ unless otherwise noted)

Type no.	Supply voltage $V_s$ max (V)	Operating temperature*1 $T_{opr}$ (°C)	Storage temperature*1 $T_{stg}$ (°C)
C13398-01	±15	0 to +40	-10 to +40
C13398-02			

\*1: No dew condensation

When there is a temperature difference between a product and the surrounding area in high humidity environment, dew condensation may occur on the product surface. Dew condensation on the product may cause deterioration in characteristics and reliability.  
Note: Exceeding the absolute maximum ratings even momentarily may cause a drop in product quality. Always be sure to use the product within the absolute maximum ratings.

#### Recommended operating conditions ( $T_a = 25\text{ °C}$ )

Type no.	Supply voltage*2 $V_s$ (V)		
	Min.	Typ.	Max.
C13398-01	±9.5	±10	±10.5
C13398-02			

\*2: Use a multiple output power supply (dual power supply) that can output 100 mA current.

#### Electrical characteristics (Typ. $T_a = 25\text{ °C}$ , $V_s = \pm 10\text{ V}$ , unless otherwise noted)

Type no.	Conversion impedance $R_f$ (V/A)	Cutoff frequency $f_c$ -3 dB (kHz)	Maximum output amplitude $V_{FS}$ (V)	Output noise voltage $V_n$ Dark state (mVp-p)	Current consumption $I_s$ Dark state (mA)
C13398-01	10 <sup>7</sup>	1.6	±9.8	1	±18
C13398-02					

Note: Customization of detection wavelengths and conversion impedance is possible.

**Optical characteristics\*3 (Typ. Ta=25 °C, Vs=±10 V, unless otherwise noted)**

Type no.	Detection wavelength $\lambda_p$ (nm)										Full width at half maximum FWHM (nm)	Blocking OD Min.
	1	2	3	4	5	6	7	8	9	10		
C13398-01	340	405	450	510	546	570	600	630	660	700	10	4
C13398-02	340	380	405	492	510	546	578	620	690	Reference light		

Type no.	Photosensitivity*4 S (mV/μW)									
	1	2	3	4	5	6	7	8	9	10
C13398-01	1080	1220	120	130	130	130	120	130	120	110
C13398-02	1080	670	1190	140	130	120	120	140	130	-

\*3: When collimated light that  $\phi 4$  mm or less is incident

\*4:  $\lambda = \lambda_p$

**Spectral response (typical example)**

C13398-01

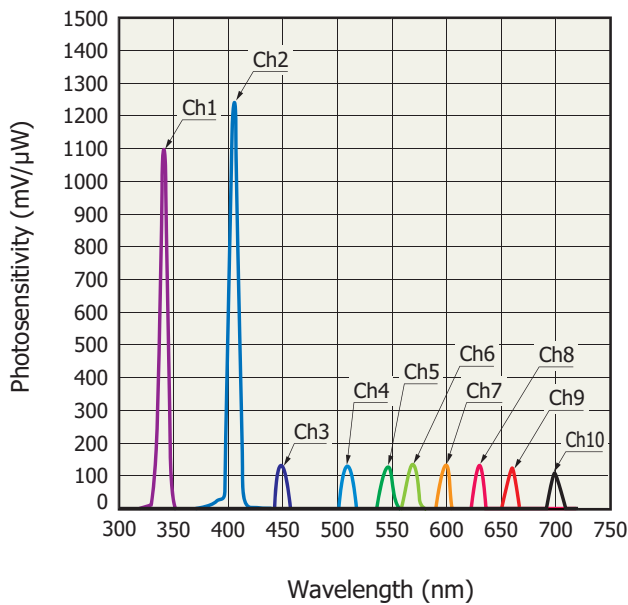

KACCB0459EB

C13398-02

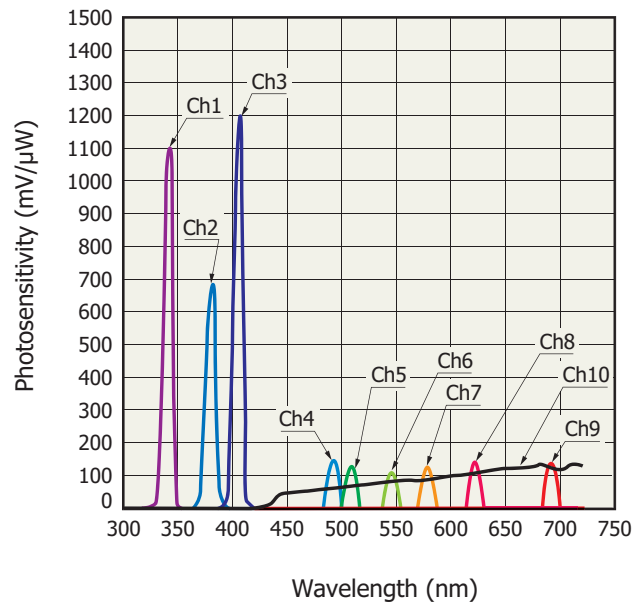

KACCB0460EB

**Block diagram**

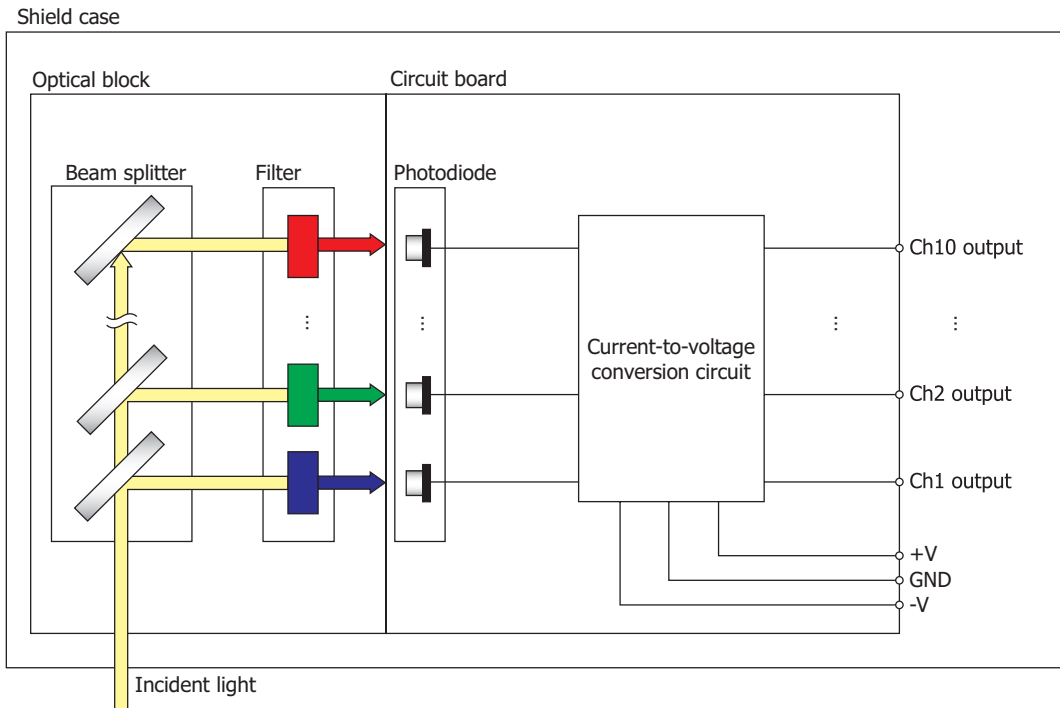

KACCC0852EB

**Dimensional outline (unit: mm)**

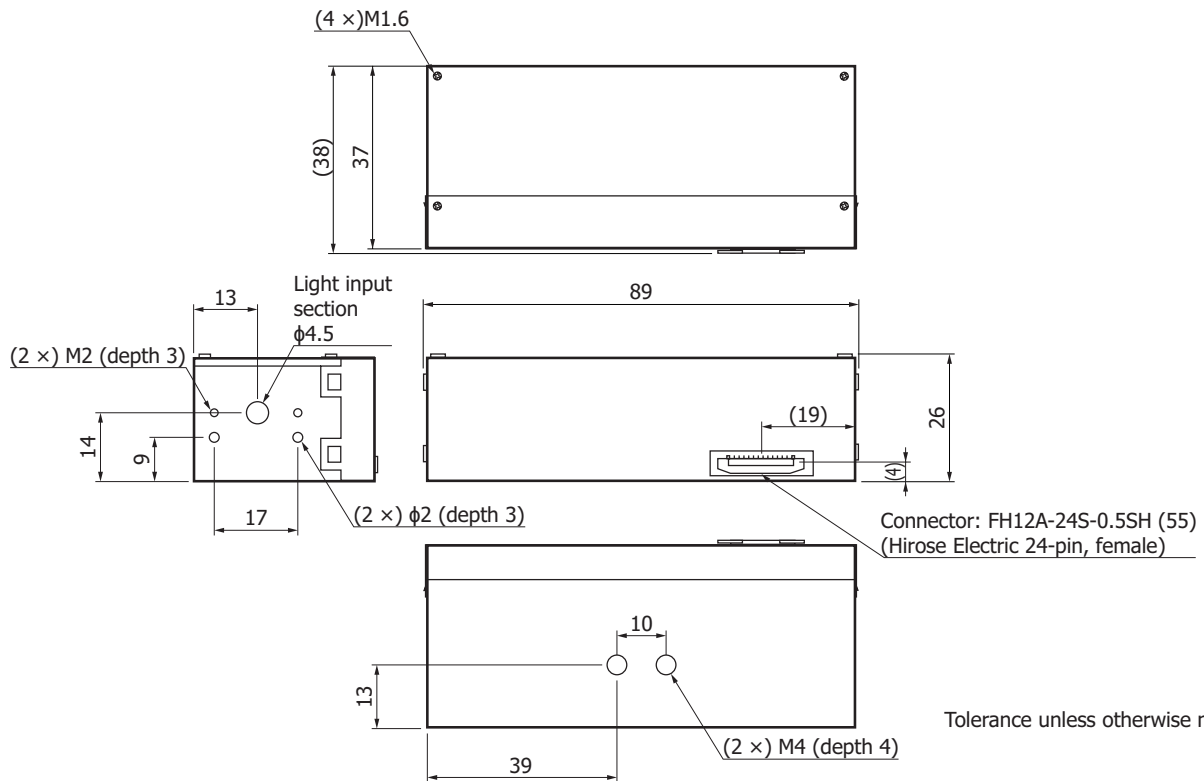

KACCA0388EB

**Pin connections**

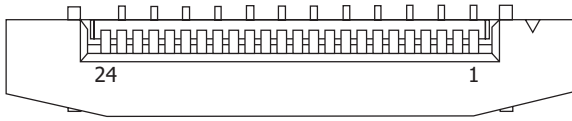

24-electrode flexible cable connector [FH12 A-24S-0.5SH (55)]

Pin no.	Name	Content
1	-Vs	-10 V input
2	G	GND
3	+Vs	+10 V input
4	G	GND
5	Vout_ch10	Output voltage (Ch10)
6	G	GND
7	Vout_ch9	Output voltage (Ch9)
8	G	GND
9	Vout_ch8	Output voltage (Ch8)
10	G	GND
11	Vout_ch7	Output voltage (Ch7)
12	G	GND
13	Vout_ch6	Output voltage (Ch6)
14	G	GND
15	Vout_ch5	Output voltage (Ch5)
16	G	GND
17	Vout_ch4	Output voltage (Ch4)
18	G	GND
19	Vout_ch3	Output voltage (Ch3)
20	G	GND
21	Vout_ch2	Output voltage (Ch2)
22	G	GND
23	Vout_ch1	Output voltage (Ch1)
24	G	GND

**Connection example**

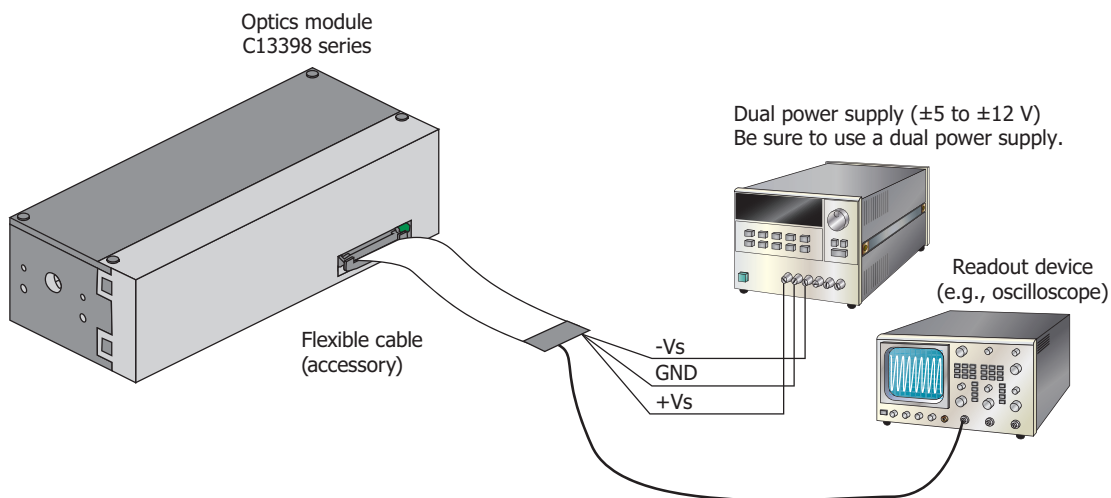

Wiring using shielded wires or AWG#26 or equivalent twisted pair wires (no longer than 150 cm) is recommended.

KACCC0853EA

### Application example (Blood analysis device)

Optics modules can be used to analyze components contained in blood by directing light on the blood and measure the transmitted light for each wavelength.

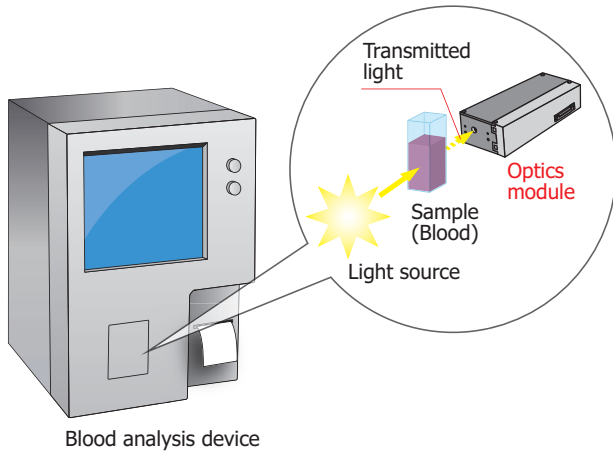

KACCC0606B

### Accessories

- Instruction manual
- Flexible cable (length: 70 mm)

### Evaluation circuit for optics module C13390

The C13390 is a dedicated evaluation circuit for the optics module (C13398 series). When the C13390 is connected to the PC through USB, the analog output signals of each channel of the C13398 series can be converted into digital signals, and the results can be acquired into the PC.

Both the C13398 series and the C13390 can be driven off of USB bus power. There is no need to prepare a separate power supply or the like. You can simply connect it to the PC through USB and perform evaluation and measurement. For the C13390 specifications, refer to the C13390 datasheet.

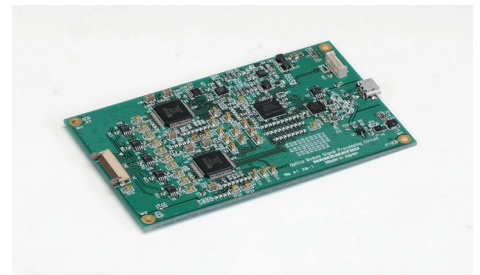

### Related information

[www.hamamatsu.com/sp/ssd/doc\\_en.html](http://www.hamamatsu.com/sp/ssd/doc_en.html)

- Precautions
- Disclaimer

Information described in this material is current as of May 2018.

Product specifications are subject to change without prior notice due to improvements or other reasons. This document has been carefully prepared and the information contained is believed to be accurate. In rare cases, however, there may be inaccuracies such as text errors. Before using these products, always contact us for the delivery specification sheet to check the latest specifications.

The product warranty is valid for one year after delivery and is limited to product repair or replacement for defects discovered and reported to us within that one year period. However, even if within the warranty period we accept absolutely no liability for any loss caused by natural disasters or improper product use. Copying or reprinting the contents described in this material in whole or in part is prohibited without our prior permission.

# HAMAMATSU

[www.hamamatsu.com](http://www.hamamatsu.com)

HAMAMATSU PHOTONICS K.K., Solid State Division

1126-1 Ichino-cho, Higashi-ku, Hamamatsu City, 435-8558 Japan, Telephone: (81) 53-434-3311, Fax: (81) 53-434-5184

U.S.A.: Hamamatsu Corporation: 360 Foothill Road, Bridgewater, N.J. 08807, U.S.A., Telephone: (1) 908-231-0960, Fax: (1) 908-231-1218, E-mail: [usa@hamamatsu.com](mailto:usa@hamamatsu.com)

Germany: Hamamatsu Photonics Deutschland GmbH: Arzbergerstr. 10, D-82211 Herrsching am Ammersee, Germany, Telephone: (49) 8152-375-0, Fax: (49) 8152-265-8, E-mail: [info@hamamatsu.de](mailto:info@hamamatsu.de)

France: Hamamatsu Photonics France S.A.R.L.: 19, Rue du Saule Trapu, Parc du Moulin de Massy, 91882 Massy Cedex, France, Telephone: 33-(1) 69 53 71 00, Fax: 33-(1) 69 53 71 10, E-mail: [infos@hamamatsu.fr](mailto:infos@hamamatsu.fr)

United Kingdom: Hamamatsu Photonics UK Limited: 2 Howard Court, 10 Tewin Road, Welwyn Garden City, Hertfordshire AL7 1BW, United Kingdom, Telephone: (44) 1707-294888, Fax: (44) 1707-325777, E-mail: [info@hamamatsu.co.uk](mailto:info@hamamatsu.co.uk)

North Europe: Hamamatsu Photonics Norden AB: Torshamnsgatan 35 16440 Kista, Sweden, Telephone: (46)8-509 031 00, Fax: (46)8-509 031 01, E-mail: [info@hamamatsu.se](mailto:info@hamamatsu.se)

Italy: Hamamatsu Photonics Italia S.r.l.: Strada della Moia, 1 int. 6, 20020 Arese (Milano), Italy, Telephone: (39)02-93 58 17 33, Fax: (39)02-93 58 17 41, E-mail: [info@hamamatsu.it](mailto:info@hamamatsu.it)

China: Hamamatsu Photonics (China) Co., Ltd.: B1201, Jiaming Center, No.27 Dongsanhuan Beilu, Chaoyang District, Beijing 100020, China, Telephone: (86) 10-6586-6006, Fax: (86) 10-6586-2866, E-mail: [hpc@hamamatsu.com.cn](mailto:hpc@hamamatsu.com.cn)

Taiwan: Hamamatsu Photonics Taiwan Co., Ltd.: 8F-3, No. 158, Section2, Gongdao 5th Road, East District, Hsinchu, 300, Taiwan R.O.C. Telephone: (886)03-659-0080, Fax: (886)03-659-0081, E-mail: [info@hamamatsu.com.tw](mailto:info@hamamatsu.com.tw)