



# Closed Cycle Electromagnet Probe Station

This model of the ARS Probe Station is designed for the ultimate in flexibility for non-destructive device testing. This system provides a .6T Horizontal Magnetic Field and comes with a BiPolar Power Supply.

This model of Probe Station accepts either our DE204 or DE210 Series of cryocoolers. These cryocoolers allow for sample stage temperatures of 13K, < 10K, or 7K depending upon the model that you choose. All of the ARS Closed Cycle Cryocoolers are designed with high first stage cooling capacity which allows for fast cool downs and dissipation of high radiative heat loads. The combination of the high first stage cooling capacity and inherently lower vibrations of the pneumatically drive GM cryocooler, make it ideal for this application.

The system comes with a Hard Coated Aluminum Vacuum Chamber and Polished OFHC Radiation Shield. The high quality materials allow for deep vacuum levels and ultimately cleaner sample environments.

ARS' integrated approach of manufacturing for both the cryocooler and the probe station ensures consistent performance, and also facilitates diagnostics and service of the integrated system.

## Applications

- Magnetic Properties
- Microwave Properties
- DC, RF Properties
- MEMS
- Nanscale Electronics
- Superconductivity
- Electrical and Optical Properties of Nano Circuits
- Quantum Dots and Wires
- Non Destructive Device Testing

## Typical Configuration

- DE204 Closed Cycle Cryocooler
- Compressor (ARS-4HW)
- 2 Helium Hoses (10 foot flex lines)
- 12" x 5" Hard Coated Aluminum Vacuum with 4 Micromanipulated Probe Ports on an Anodized Aluminum Table Top with Extruded Aluminum Support System.
- GMW 5403 EG Electromagnet capable of 0.6T
- (2) Kepco BOP Power Supplies wired in Parallel
- Polished OFHC Copper Radiation Shield
- 1" Square Grounded Sample Holder made out of OFHC Copper.
- 3 Stage Vibration Dampening System for < 1 micron Vibration Levels at the Sample Stage
- DC, Microwave, or Fiber Optic Probes
- 4 Sensors and 2 Heaters for temperature control and monitoring
- Lakeshore LS336 (4) Channel Temperature Controller with interconnecting cable to the cryostat.
- Lakeshore 475 Gaussmeter with Cryogenic Hall Sensor
- 7:1 Zoom Microscope with <2 micron resolution and coaxial or ring light. Includes a High Resolution 24" Wide Screen LCD Display and a light source for the microscope.

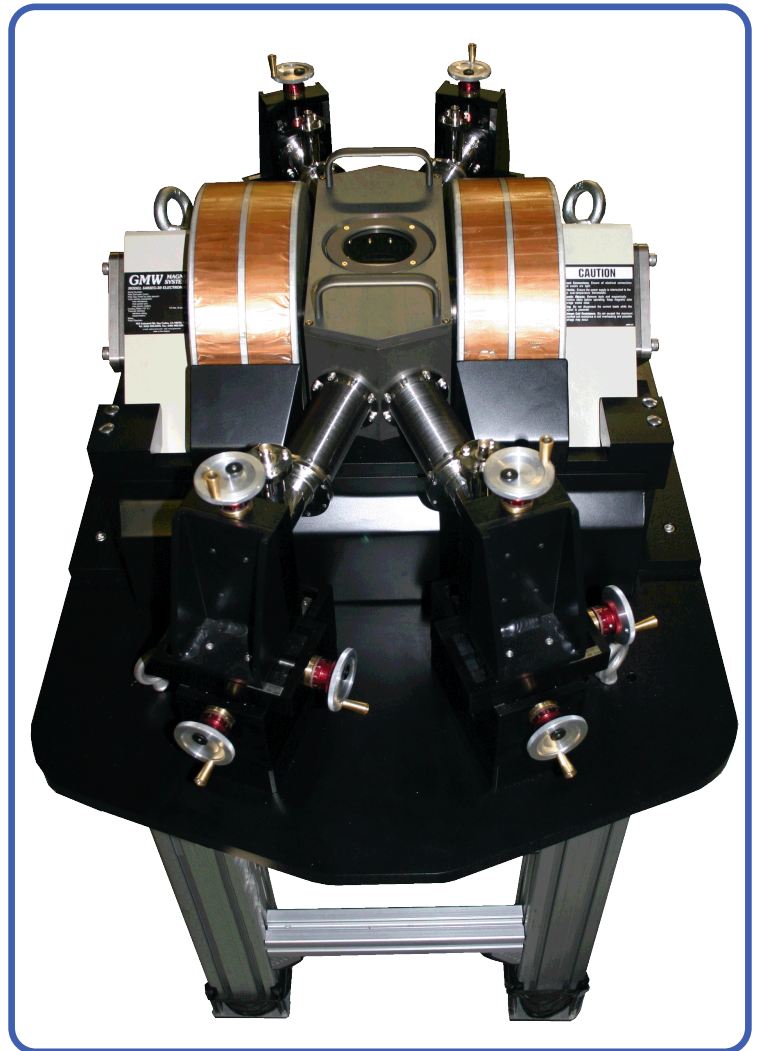



# Closed Cycle Electromagnet Probe Station

## Cooling Technology-

DE-204 / DE-210	Closed Cycle Cryocooler
Refrigeration Type	Pneumatically Driven GM Cycle
Liquid Cryogen Usage	None, Cryogen Free

## Vacuum Chamber-

Material	Aluminum
Length	12" (254 mm)
Width	5" (127 mm)
Probe Ports	4
Lid	Removable Lid with Quartz Window.
Mounted On	39" x 25" Anodized Aluminum Plate
Optical Access	
Window Material	High Purity Quartz
Window Diameter	2.75" (69 mm)
Window Clear View	2.5" (63 mm)

## Radiation Shield-

Material	OFHC Copper
Length	5.5" (140 mm)
Width	2.875" (73 mm)
Ports	4 (standard)
Lid	Removable Lid with Sapphire Cold Window.
Mounted On	1st stage of Cryocooler
Optical Access	
Window Material	Sapphire
Window Diameter	2" (51 mm)
Window Clear View	1.375" Square (35 mm)

## Sample Holders\*-

Grounded	1" Square (standard)
Electrically Isolated	1" Square (Optional)
Coaxial (Biased)	1" Square (Optional) Includes BNC Feedthrough with Coaxial Cable to sample stage
Triaxial (Biased with Guard)	1" Square (Optional) Includes Triaxial Feedthrough with Coaxial or Triaxial wire.

\*Custom sample holders also available.

## Temperature Range\*-

DE-204AF*	< 10K - 350K
Sample Stage Temp.	<b>~13K - 400K</b>
DE-204PF*	< 5.5K - 350K
Sample Stage Temp.	<b>~10K - 400K</b>
DE-210SF*	< 3K - 350K
Sample Stage Temp.	<b>~7K - 400K</b>
With 500K Interface	Add ~3K - 500K
With 800K Interface	Add ~3K - 800K
Stability	0.1K (Can tune better with PID Control)

\*Based on bare cold head with a closed radiation shield, and no additional sources of experimental or parasitic heat load

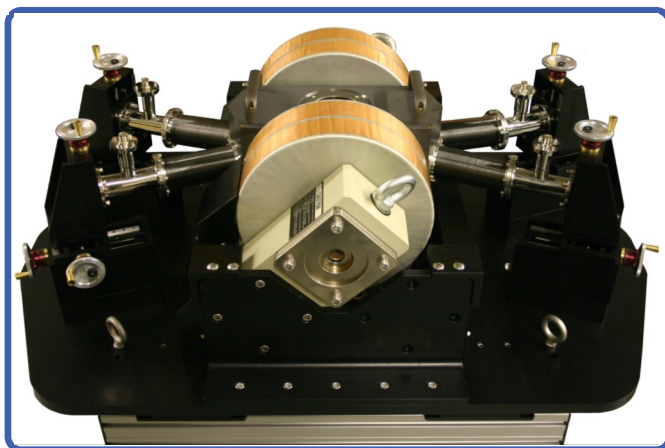

The above picture shows the 4 probes connected to the vacuum chamber. This is a side profile of the table top and does not show the cryocooler underneath.



The above picture shows the sample space inside the probe station.



# Closed Cycle Electromagnet Probe Station

## Magnetic Field\*-

Electromagnet	GMW 5403 EG
Magnetic Field Direction	Horizontal
Magnetic Field Strength	0.6T
Pole Face	76 mm
Coil Spacing	5.2" (132 mm)
Pole Spacing	
Water Flow Rate	2 l/min, 0.8 bar (0.5 US GPM, 12 psid)
Power Supply - Bipolar	(2) Kepco BOP wired in parallel
Voltage	+/- 20V
Amperage	+/- 40A
Gaussmeter	Lskeshore 475 DSP
Hall Sensor	Lakeshore HGCT-3020
*Power Supplies, Gaussmeters, and Temperature Controller are installed on a Rack System.	
*Interconnecting cables from the Power Supplies and Gaussmeter to the Probe Station are Supplied.	

## Translation Stages-

Drive	Direct Drive
Bellows	Stainless Steel, Edge Welded
Motion	
X-Motion (Axial)	2" (50 mm) Standard
Y-Motion (Lateral)	1" (25 mm) Standard
Z-Motion (Vertical)	0.5" (12.5 mm) Standard
Graduations	10 micron
Sensitivity	5 micron

## Vibration Levels-

Sample Stage Vibrations	< 1 micron
Vibration Dampening	3 Stages
Stage 1 (Low Frequency)	Soft Air Mount Feet for High Shock
Stage 2 (High Frequency)	Elastomeric Isolators installed between the frame and the table top.
Stage 3 (Sample Stage)	Supersoft Copper Braids to transmit maximum cooling power and minimal vibrations from the cold tip to the sample stage.

## Cool Down and Pump Down Time-

Pump down Time* (<5 mTorr)	
Mechanical Pump (VPS-2)	~ 45 minutes
Turbo Pump (VPS-3)	~ 10 minutes
Cool down time to 10K**	~2 - 2 1/2 hours
*The pump down time listed are approximate timelines using an ARS supplied vacuum pumping system. Actual vacuum levels of the system will be dependent of the vacuum pump itself. The system is capable of allowing for vacuum levels of 10 <sup>-6</sup> Torr with an appropriate vacuum pumping system.	
**The cool down time to 10K is listed for the DE204P cryocooler under typical conditions. If customizations are made, or only a 10K cryocooler is chosen, then 10K sample stage temperatures may not be achievable.	

## Instrumentation for Temperature Control\*-

Temperature Sensors	Silicon Diodes and Cernox RTD
DT-670B-SD	Installed on the radiation shield
CX-1030-SD-HT	Calibrated Cernox Sensor Installed on the underside of the sample chuck for temperature control.
DT-670B-SD	Installed on the cryocooler cold tip for diagnostics
CX-1030-CU-HT	Calibrated Cernox Sensor installed on top of the sample stage for accurate sample stage temperatures
Heaters	
50W Cartridge Heater	Installed on the under side of the sample stage for temperature control.
(2) 50W Cartridge Heaters	Installed in parallel on the radiation shield to allow for 100W of heater power to assist in fast warm up of the system.
Temperature Controller	LS-336 4 Channel Temperature Controller with 150W heater power.
*Interconnecting cables from the probe station to the temperature controller are supplied.	



# Closed Cycle Electromagnet Probe Station

## GSG Microwave Frequency Probe Arms\*-

\*All GSG Microwave Frequency Probe Arms include the Translation Stages. Probe arms are thermally anchored to the sample chuck and include +/- 5° Theta Planarization

<b>40 GHz</b>	<b>Optional</b>
Connector	K
Cable	Semirigid Coaxial
Frequency	0 to 40 GHz
Tip Material	Tungsten Beryllium Copper
Pitch	50 - 2450 micron (100 or 150 micron Typical)
<b>50 GHz</b>	<b>Optional</b>
Connector	2.4
Cable	Semirigid Coaxial
Frequency	0 to 50 GHz
Tip Material	Tungsten Beryllium Copper
Pitch	50 - 1250 micron (100 or 150 micron Typical)
<b>67 GHz</b>	<b>Optional</b>
Connector	1.85
Cable	Semirigid Coaxial
Frequency	0 to 67 GHz
Tip Material	Tungsten Beryllium Copper
Pitch	50 - 1250 micron (100 or 150 micron Typical)

## DC/Low Frequency Probe Arms\*-

\*All DC/Low Frequency Probe Arms include the Translation Stages. Probe arms are thermally anchored to the sample chuck.

<b>Microminiature Coax Cable</b>	<b>Standard</b>
Connector	SMA or BNC
Frequency	0 to 100 MHz
Impedance	50 Ohm
Includes Outer Ground Shield with Clip Connector	
<b>Triaxial Cable</b>	<b>Optional</b>
Connector	Triaxial - 3 Lug
Frequency	0 to 100 MHz
Impedance	50 Ohm
<b>Kelvin Probes**</b>	<b>Optional</b>
Cable	Coaxial or Triaxial
Connector	SMA, BNC, or Triaxial
Frequency	0 to 100 MHz
<b>Probe Tips:</b>	
Material	Tungsten (Standard) Gold Plated Tungsten (Optional) Beryllium Copper (Optional)
Tip Radius	0.5 micron (standard) Other radius' also available

\*\*Kelvin Probes use 2 cables and 2 connectors, but converge down to a single tip.

## Fiber Optic Probe Arms\*-

Range	UV/VIS or VIS/IR
Connector	Male SMA 905
Sample Termination	Bare Polished
Size (Typical)	100 micron - 400 micron
Mode	Single Mode or Multi Mode
Cable Material	Polyimide, Fused Silica
*All Fiber Probe Arms include the Translation Stages. This does not include a light source or detector.	

## GigE Microscope with Zoom Lens\*-

Zoom	7:1 (Standard)	16:1 (Optional)
Sensor	1/2" CMOS	1/2" CMOS
Field of View	4.2 mm - 0.61 mm	12.8 mm - 0.8 mm
Working Distance	89 mm	89 mm
N.A.:	0.024 - 0.08	0.0090 - 0.15
Light (Includes Light Source)	Ring or Coaxial	Ring of Coaxial
Resolution	3 microns	2 microns
Stand	Boom Stand with	Boom Stand with
Computer Interface	Ethernet Cable	Ethernet Cable
High Resolution Monitor	24"	24"



# Closed Cycle Electromagnet Probe Station

## Electromagnet Probe Station Outline Drawing

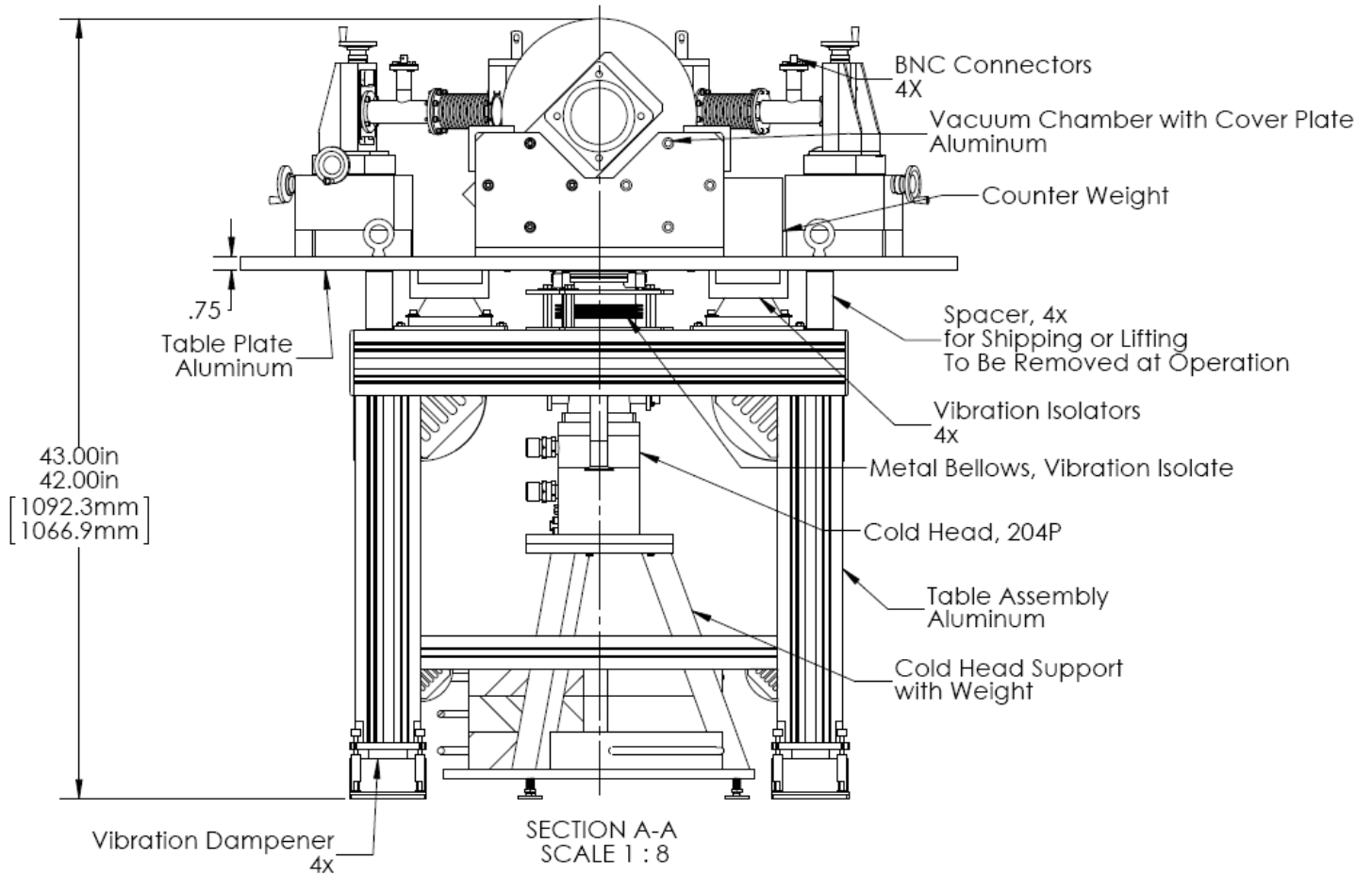

The above image shows a side profile of a probe station. The above system shows a DE204P Cryocooler, which can be substituted with a DE204A or a DE210S cryocooler.



# Closed Cycle Electromagnet Probe Station

**Probe Station Top Down Drawing**

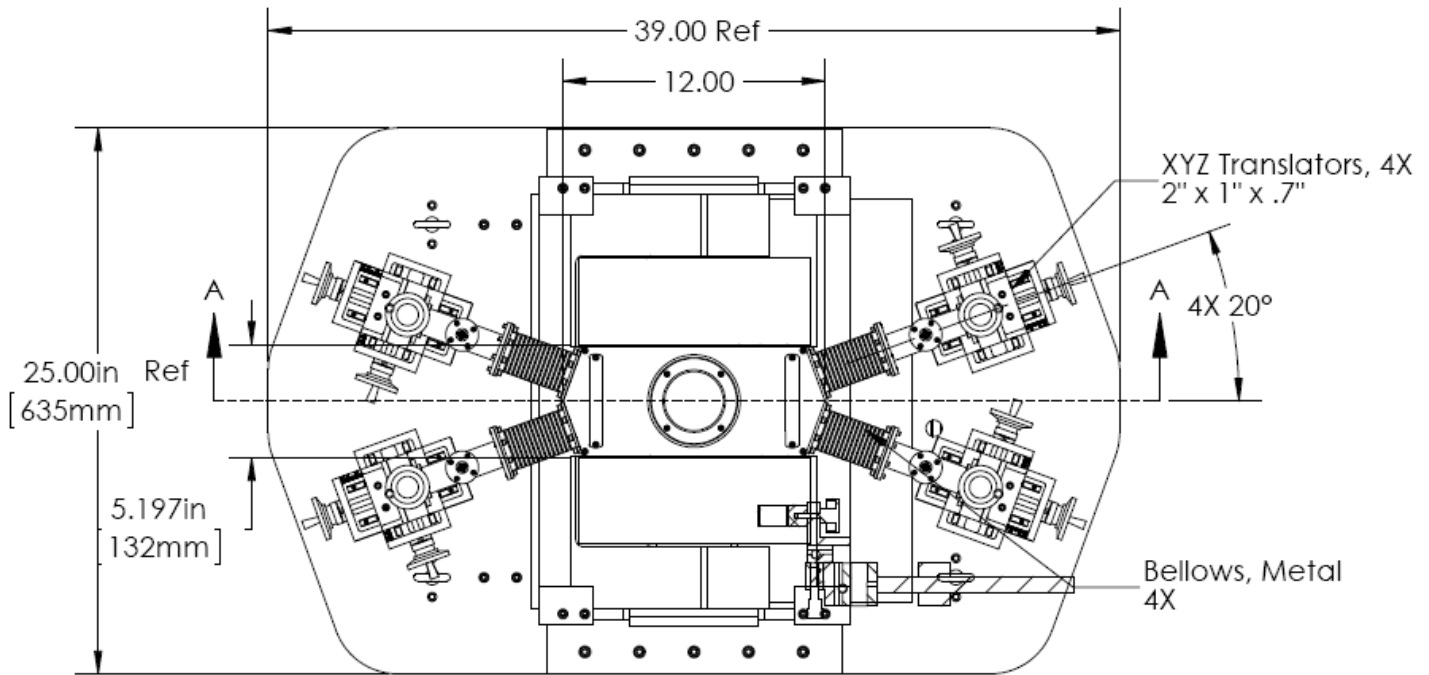

There are (4) DC/Low Frequency Probes. The system does allow for Fiber Optic or Microwave Probes as well.

Cryocooler Model		DE-204AF		DE-204PF		DE-210SF	
	Frequency	60 Hz	50 Hz	60 Hz	50 Hz	60 Hz	50 Hz
<b>Base Temperature</b>		<9K	<9K	<5.5K	<5.5K	<3K	<3K
<b>Cooling Capacity</b>	4.2K	-	-	-	-	0.8W	0.8W
	10K	2W	1.6W	3.5W	2.8W	9W	9W
	20K	9W	7.2W	8W	6.4W	16W	16W
	77K	17W	14W	14W	11W	25W	25W
<b>Radiation Shield Cooling Capacity</b>		18W	14W	18W	14W	60W	60W
<b>Cooldown Time</b>	20K	30 min	36 min	40 min	48 min	40 min	40 min
	Base Temperature	60 min	72 min	80 min	102 min	80 min	80 min
<b>Compressor Model</b>		ARS-4HW		ARS-4HW		ARS-10HW	
<b>Typical Maintenance Cycle</b>		12,000 hours		12,000 hours		12,000 hours	

The above chart shows the cooling capacities and base temperatures of the bare cryocoolers. These base temperatures are not of the sample stage. Please see the chart on page 2 of this data sheet for approximate sample stage temperatures.



# Closed Cycle Electromagnet Probe Station

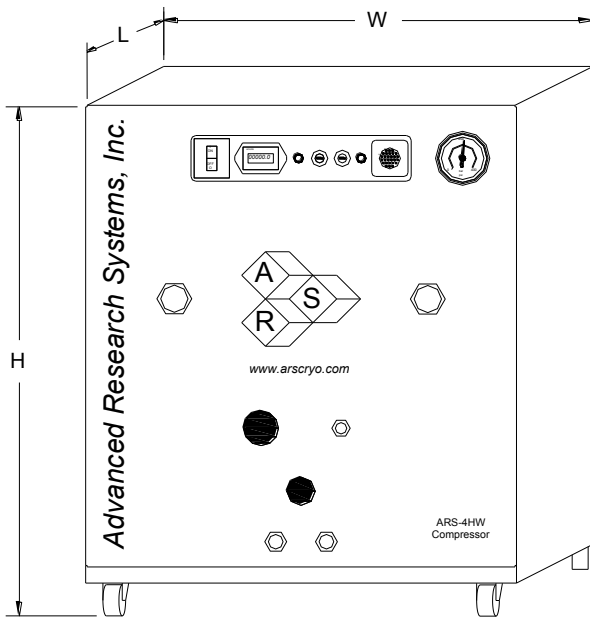

ARS-4HW Compressor

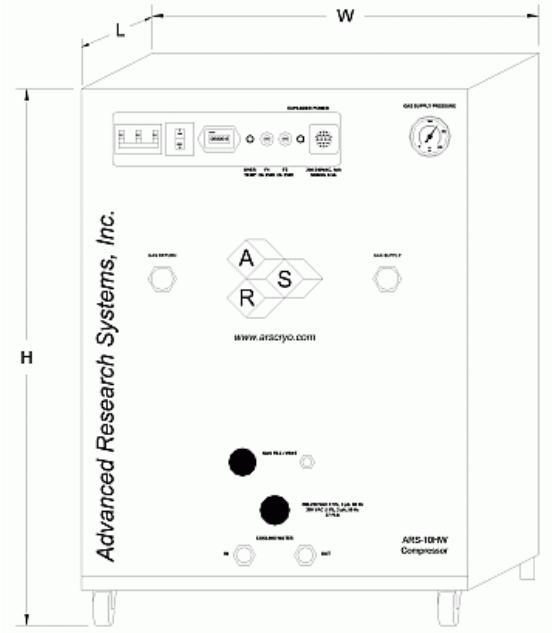

ARS-10HW Compressor

Compressor Model		ARS-4HW		ARS-10HW	
	Frequency	60 Hz	50 Hz	60 Hz	50 Hz
<b>Standard Voltage</b>	Min	208 V	190 V	208 V	190 V
	Max	230 V	210 V	230 V	210 V
<b>Transformer Options</b>	10%		220 V, 230 V		
	15%		240 V		
<b>High Voltage</b>	Min			440 V	380 V
	Max			480 V	415 V
<b>Power Usage</b>	Phase	(1 Ph) 3.6 kW	(1 Ph) 3.0 kW	(3 Ph) 7.7 kW	
<b>Refrigerant Gas</b>		99.999% Helium Gas, Pre-Charged			
<b>Noise Level</b>		60 dBA			
<b>Ambient Temperature</b>		12 - 40 C (54 - 104 F)		5 - 40 C (40 - 104 F)	
<b>Cooling Water</b>	Consumption	2.3 L / min (0.6 Gal. / min)		5.7 L / min (1.5 Gal. / min)	
	Temperature	10 - 35 C (50—95 F)		< 20C (68F)	
	Connection	3/8 in. Swagelok Fitting		1/2 in. Swagelok Fitting	
<b>Dimensions:</b>	L	483 mm (19 in)		483 mm (19 in)	
	W	434 mm (17.1 in)		533 mm (21 in)	
	H	516 mm (20.3 in)		617 mm (24.3 in)	
<b>Weight</b>		72 kg (160 lbs)		105 kg (230 lbs)	
<b>Typical Maintenance Cycle</b>		12,000 hours		12,000 hours	
<b>Water Recirculation Option</b>		CoolPac Compatible		Not CoolPac Compatible	

The above chart shows the typical specifications for the ARS-4HW and ARS-10HW Compressor.