



Optical Cryostat - Ultra Low Vibrations

The **CS204*F-DMX-20** opens up a wide range of possibilities never before possible with a closed cycle cryocooler. The DE204*F-DMX-20 uses a Helium Exchange Gas to decouple the sample from the cold tip of the DE204 Cryocooler. This prevents almost all vibration from being transmitted to the sample. Sample vibration levels of 3-5nm have been demonstrated by users. Due to the exchange gas being less conductive, the base temperature will increase by 1-2K and the cooling Capacity is roughly cut in half at varying temperatures.

Applications

- Mössbauer
- Low Vibration Optical Experiments
- Quantum Dots
- Photoluminescence (PL)
- Micro-Raman (Micro-PL)
- Micro-Spectroscopy
- Magneto Optical Kerr Effect (MOKE)
- Nanoscience
- Ellipsometry

Features

- **Ultra Low Vibrations (3-5 nm)**
- Pop-Off optical block for easy in-situ sample change
- Beryllium and Kapton windows available for Mössbauer experiments
- Large clear view optical windows (1.25 in)
- Large sample viewing angle for optical collection (F/1.4)
- Cold Tip Down Orientation
- Fully customizable

Typical Configuration

- Cold head (DE-204AF)
- Compressor (ARS-4HW)
- 2 Helium Hoses
- Aluminum vacuum shroud with 4 window ports for optical and electrical measurements with 4 window ports on a pop-off optical block
- Nickel Plated OFHC copper radiation shield
- 2 High purity quartz windows
- Instrumentation for temperature measurement and control:
 - 10 pin hermetic feed through
 - 50 ohm thermofoil heater
 - Silicon diode sensor curve matched to ($\pm 0.5K$) for control
 - Calibrated silicon diode sensor (± 12 mk) with 4 in. free length for accurate sample measurement.
- Wiring for electrical experiments:
 - 10 pin hermetic feed through
 - 4 copper wires
- Sample holder for optical and electrical experiments
- Temperature Controller

Options and Upgrades

- 4K Coldhead (0.2W @ 4.2K)
- 5.5K Coldhead (3W @ 10K)
- 450K High Temperature Interface
- 800K High Temperature Interface
- Turbo upgrade for faster cooldown times
- Custom temperature sensor configuration (please contact our sales staff)
- Custom wiring configurations (please contact our sales staff)
- Window material upgrades (custom materials available)
- Sample holder upgrades (custom sample holders available)

DS-CS204AF-DMX-20-R4



The above picture shows a cryocooler with a vacuum shroud, radiation shield, and sample holder installed.



The above picture shows the compressor for the system. What is not shown is a required vacuum pump, Helium Hoses (included with system), temperature controller and Helium Gas bottle with regulator for the exchange gas.



Optical Cryostat - Ultra Low Vibrations

Cooling Technology-

DE-204	Closed Cycle Cryocooler
Refrigeration Type	Pneumatically Driven GM Cycle
Liquid Cryogen Usage	None, Cryogen Free

Temperature*- DMX-20 adds 1-2K to base temperature

DE-204AF	< 10K - 350K
DE-204P4	< 4.2K - 350K
DE-202SF	< 5.5K - 350K
With 800K Interface	(Base Temp + 2K) - 700K
With 450K Interface	(Base Temp + 2K) - 450K
Stability	0.1K
*Based on bare cold head with a closed radiation shield, and no additional sources of experimental or parasitic heat load	

Sample Space -

Diameter	47 mm (1.87 in.)
Height	39 mm (1.53 in.)
Sample Holder Attachment	1/4 - 28 screw
Sample Holder	www.arscryo.com/Products/SampleHolders.html

Optical Access-

Window Ports	4 - 90° Apart
Diameter	41 mm (1.63 in)
Clear View	32 mm (1.25 in)
#/F	1.4
Window Material	www.arscryo.com/Products/WindowMaterials.html

Temperature Instrumentation and Control - (Standard) -

Heater	50 ohm Thermofoil Heater anchored to the coldtip
Control Sensor	Curve Matched Silicon Diode installed on the coldtip
Sample Sensor	Calibrated Silicon Diode with free length wires
Contact ARS for other options	

Instrumentation Access-

Instrumentation Skirt	Bolt-On, Stainless Steel
Pump out Port	1 - NW 25
Instrumentation Ports	2
Instrumentation Wiring	Contact sales staff for options

Vacuum Shroud -

Material	Aluminum
Length	388 mm (15.29 in)
Diameter	86 mm (3.38 in) at the sample space
Width	86 mm (3.38 in) at the sample space

Radiation Shield -

Material	Nickel Plated OFHC Copper
Attachment	Threaded
Optical Access	0, 2, or 4 (customer specified)

Cryostat Footprint -

Overall Length	562 mm (25.4 in)
Motor Housing Diameter	114 mm (4.5 in)
Rotational Clearance	200 mm (8 in) with "G" Configuration

Cryocooler Model		DE-204AF		DE-204A(T)F		DE-204PF		DE-204SF	
	Frequency	60 Hz	50 Hz	60 Hz	50 Hz	60 Hz	50 Hz	60 Hz	50 Hz
Base Temperature		<9K	<9K	<9K	<9K	<5.5K	<5.5K	<4.2K	<4.2K
Cooling Capacity	4.2K	-	-	-	-	-	-	0.2W	0.16W
	10K	2W	1.6W	2.7W	2.2W	3.5W	2.8W	4W	3.2W
	20K	9W	7.2W	12W	9.6W	8W	6.4W	8W	6.4W
	77K	17W	14W	23W	18.4W	14W	11W	14W	11W
Radiation Shield Cooling Capacity		18W	14W	24W	19W	18W	14W	18W	14W
Cooldown Time	20K	30 min	36 min	25 min	30 min	40 min	48 min	40 min	48 min
	Base Temperature	60 min	72 min	50 min	60 min	80 min	102 min	90 min	108 min
Compressor Model		ARS-4HW		ARS-4HW		ARS-4HW		ARS-4HW	
Typical Maintenance Cycle		12,000 hours		8,000 hours		12,000 hours		12,000 hours	



Optical Cryostat - Ultra Low Vibrations

DE202*F-DMX-20 Vibration Spectra

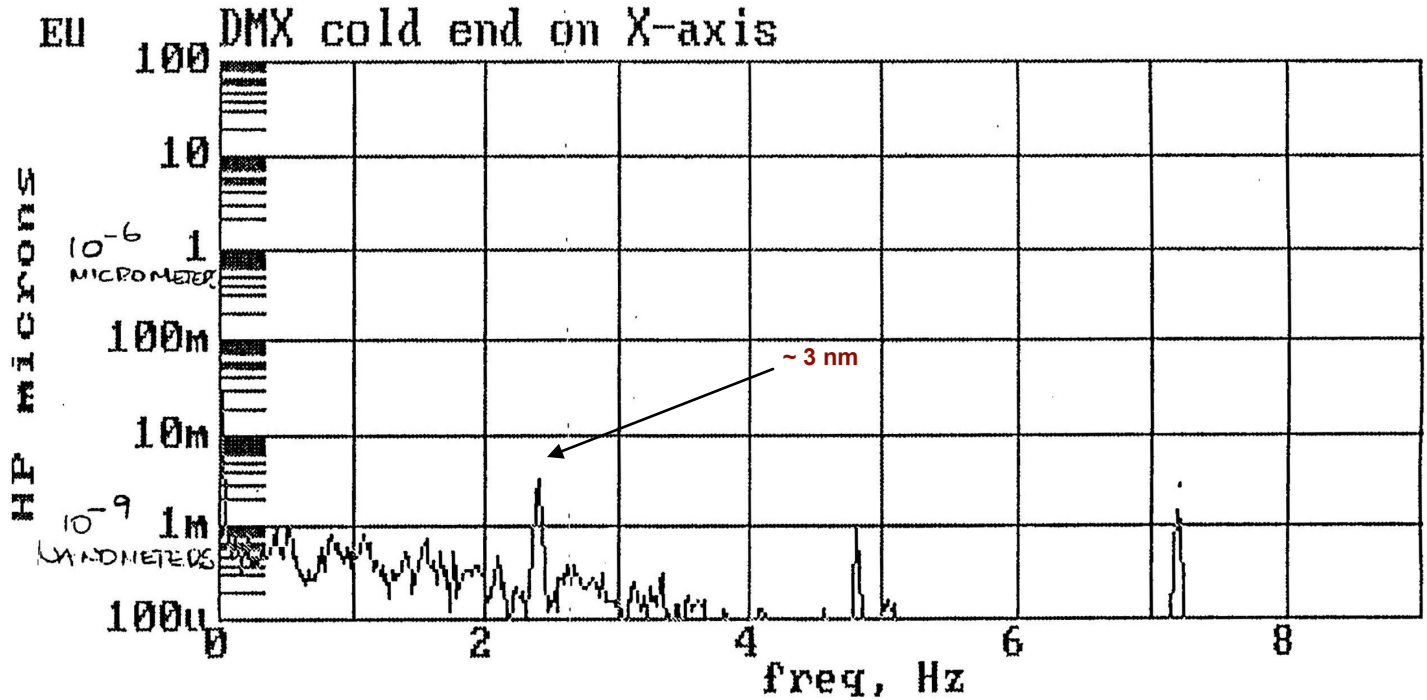

Understanding the DMX-20 Interface

The X-20 Interface uses a Helium Exchange Gas to decouple the sample space from the cold tip of the cryocooler. This prevents almost all vibration from being transferred to the sample space. Scientists have demonstrated vibration levels as low as 3-5 nm with the DE202*F-DMX-20 (as shown above)

1. The Cryocooler is supported from a Floor Stand
2. The soft rubber bellows minimize vibrations transmitted to the sample while keeping in the Helium Exchange Gas
3. The X-20 interface has no contact with the cryocooler except through the rubber bellows.
4. The cold tip has 10-30 micron vibrations (depending on CCR model) but no direct contact with the sample space.
5. Convective pockets of Helium Exchange Gas cools the sample space.
6. The sample is only in contact with the X-20 Interface
7. Windows for Optical Experiments
8. The X-20 Interface is mounted directly on a (user provided) Vibration Isolation Table.

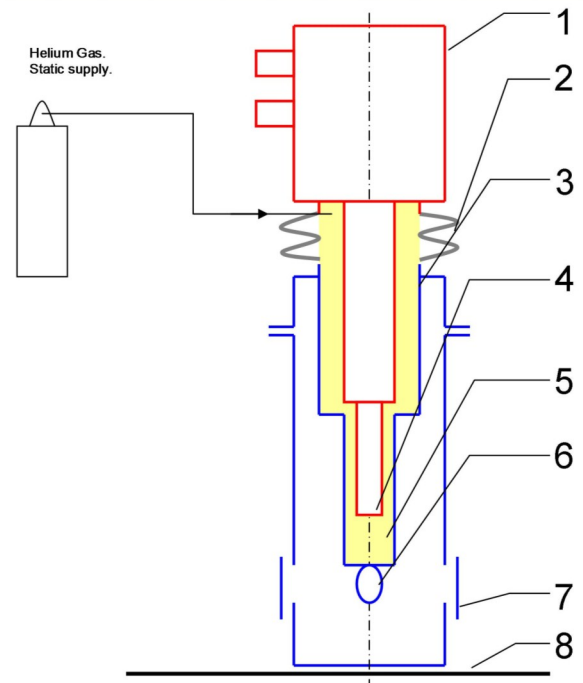



Optical Cryostat - Ultra Low Vibrations

DE204*F-DMX-20 Outline Drawing

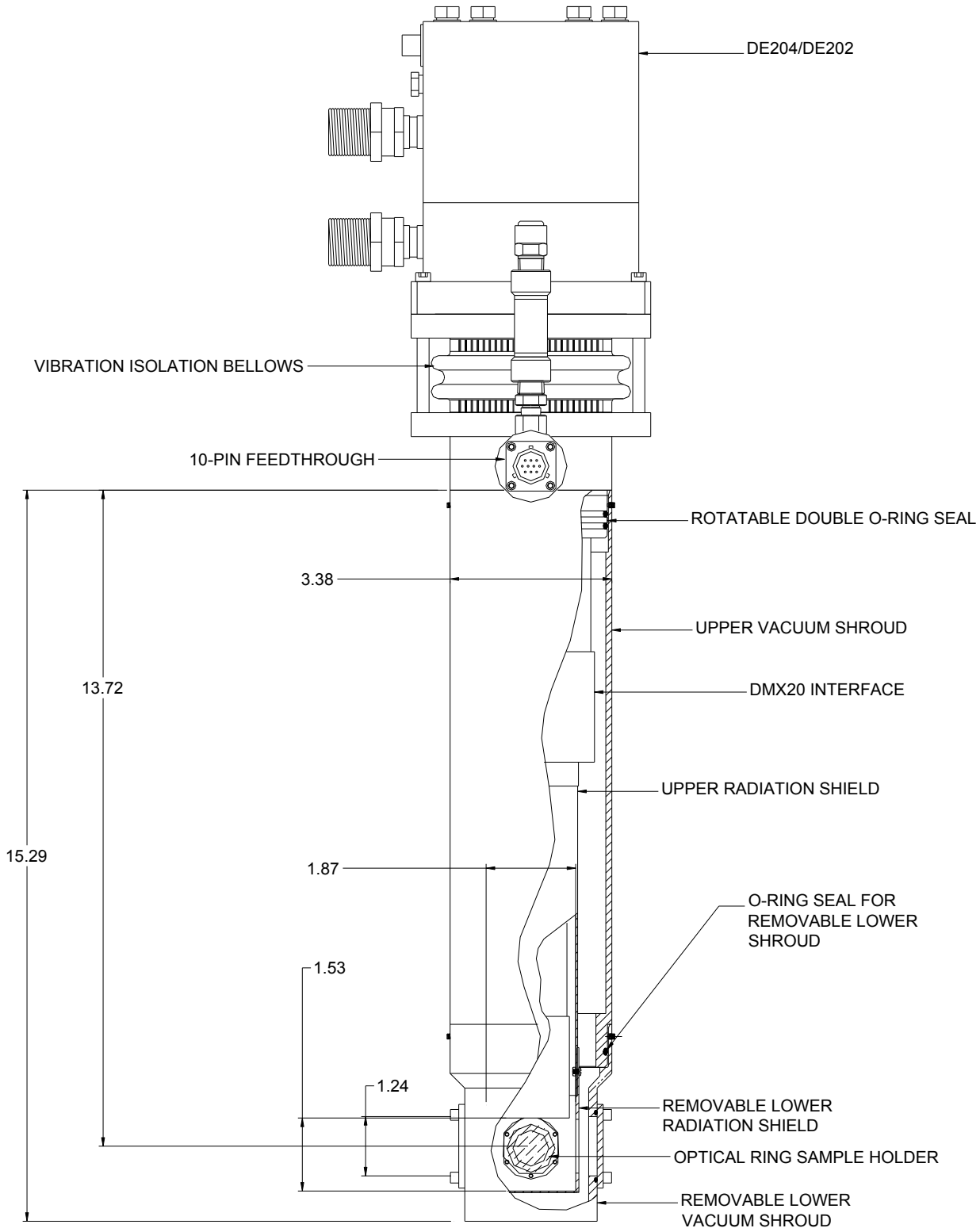



Optical Cryostat - Ultra Low Vibrations

Direct Mounting



The DMX-20 can be direct mounted on the Cryocooler. The vibrations at the sample will go up to 140 nm. It can be useful if the sample has to be translated in XYZ.

ARS-4HW Compressor

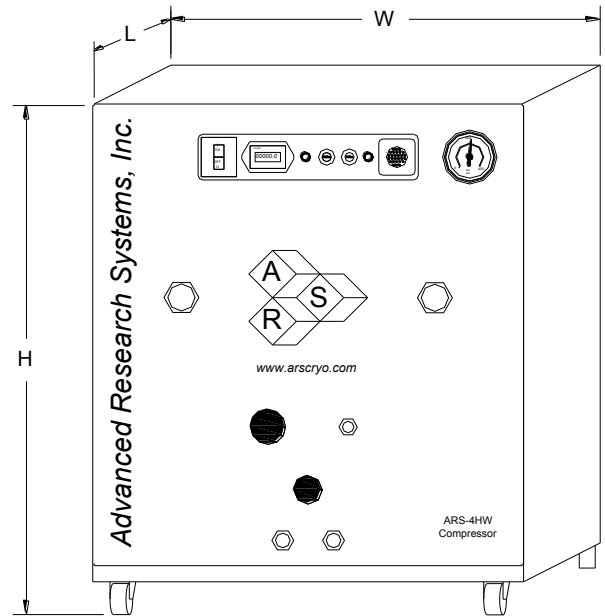

Compressor Model		ARS-4HW	
	Frequency	60 Hz	50 Hz
Standard Voltage	Min	208 V	190 V
	Max	230 V	210 V
Transformer Options	10%		220 V, 230 V
	15%		240 V
Power Usage	Single Phase	3.6 kW	3.0 kW
Refrigerant Gas		99.999% Helium Gas, Pre-Charged	
Noise Level		60 dBA	
Ambient Temperature			
Cooling Water	Consumption	2.3 L / min (0.6 Gal. / min)	
	Temperature	10 - 35 C (50—95 F)	
	Connection	3/8 in. Swagelok Fitting	
Dimensions:	L	483 mm (19 in)	
	W	434 mm (17.1 in)	
	H	516 mm (20.3 in)	
Weight		72 kg (160 lbs)	
Typical Maintenance Cycle		12,000 hours	
Water Recirculation Option		CoolPac Compatible	

Floor Stand

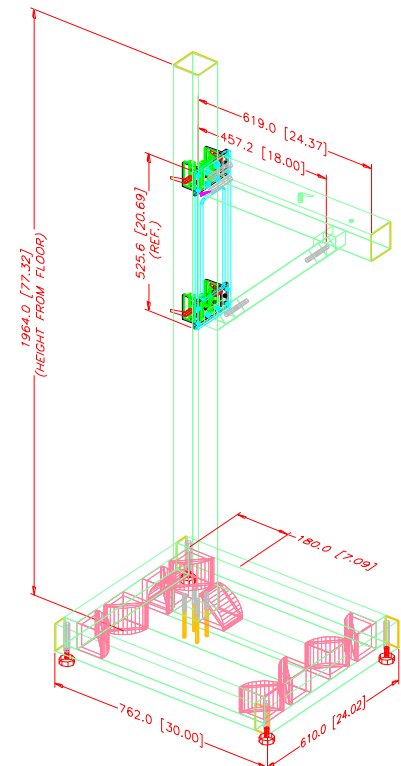



Optical Cryostat - Ultra Low Vibrations

Mossbauer Spectra with DMX-20

Cryocooler Off

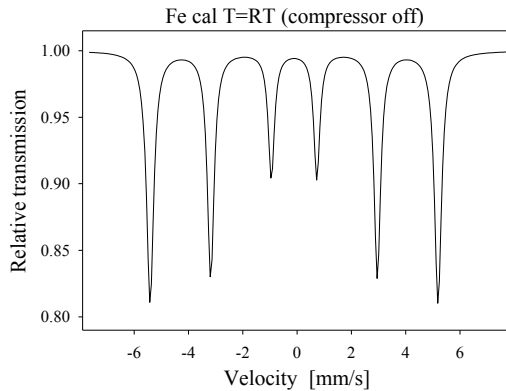

Calculated parameters:

WID=0.269 mm/s
W13=1.17

W23=1.08

ISO=0.000 mm/s

BHF=32.94T

Calibration spectrum:

Measurement with metallic iron foil (thickness 25 mm)

Cryocooler On

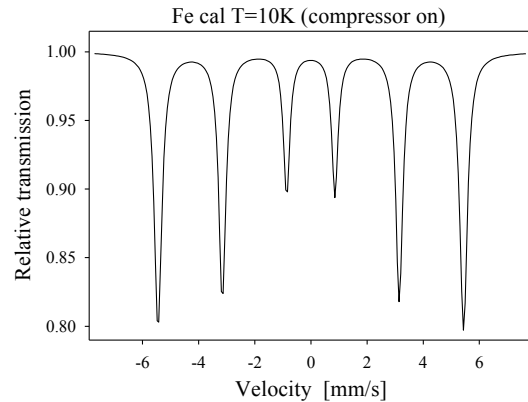

Calculated parameters:

WID=0.270 mm/s
W13=1.21

W23=1.11

ISO=+0.115 mm/s

BHF=33.81T

Calibration spectrum:

Measurement with metallic iron foil (thickness 25 mm)

When the system is properly mounted to the wall and the table and properly adjusted then the effect of vibrations induced by the working compressor is very small (almost negligible).

The broadening (rather no broadening!) is fully reproducible and is well below 2%. Such broadening has practically no effect and in almost all cases can be ignored. However, compare the line widths calculated in the same way!

The Displex system is virtually vibration free!

Prof. Dr. habil. Michal Kopcewicz

Institute of Electronic Materials Technology

WARSAW, Poland

Mossbauer Cryostat, DMX-20

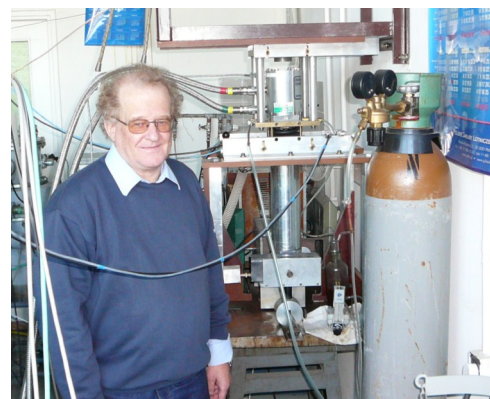

Prof. Dr. habil. Michal Kopcewicz



Optical Cryostat - Ultra Low Vibrations

SEM Setup



The picture shows the Displex and its interface. All items showing stainless steel in the photo are modifications to our JSM-5910 SEM. Please also note the published papers on my website, which demonstrate CL results that were acquired with this cooling system.

The sample temperature, is between 40 K and 50 K.

Courtesy; Prof. Dan Rich, Ben Gurion University, Beer Sheva, Israel.

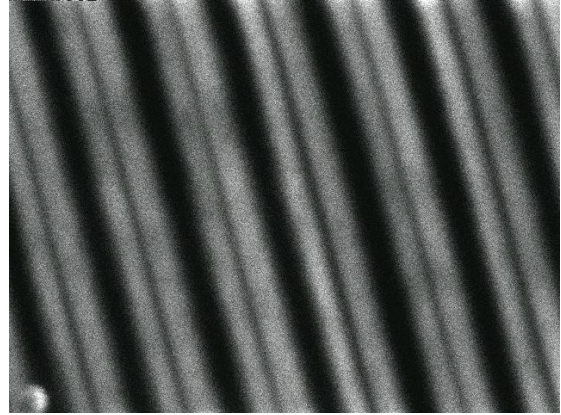
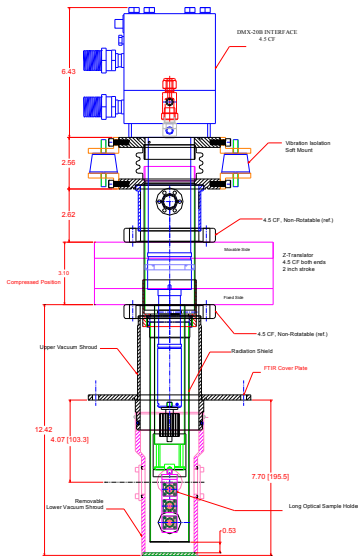

Image of a InGaN/GaN quantum well grown on a patterned GaN substrate. The patterning consists of stripes with a periodicity of 10 microns.

Monochromatic CL image (Mag. 2000) taken with a 390 nm detection wavelength.

The degradation of image quality from room temperature and 50K suggests that the vibration is less than 10nm.

FTIR Setup



Low Vibration system for FTIR spectrometer. Sample holder with 3 samples can be translated in Z direction.



Low Vibration system for BOMEM, DA8 FTIR spectrometer.



Optical Cryostat - Ultra Low Vibrations

Magneto Electrical Experiments

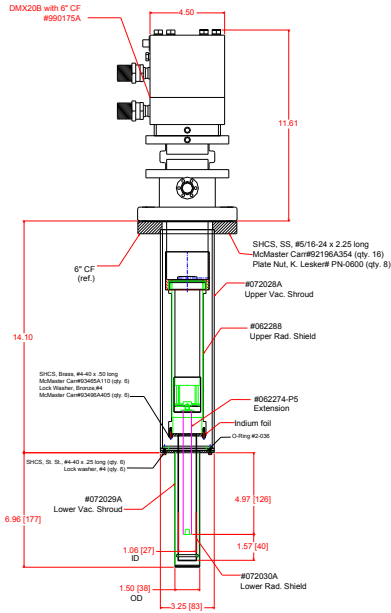

The vacuum shroud becomes narrow to permit sample insertion into a small magnet pole space.

The vacuum shroud becomes narrow to permit sample insertion into a small magnet pole space.

Magneto Optical Experiments (MOKE)

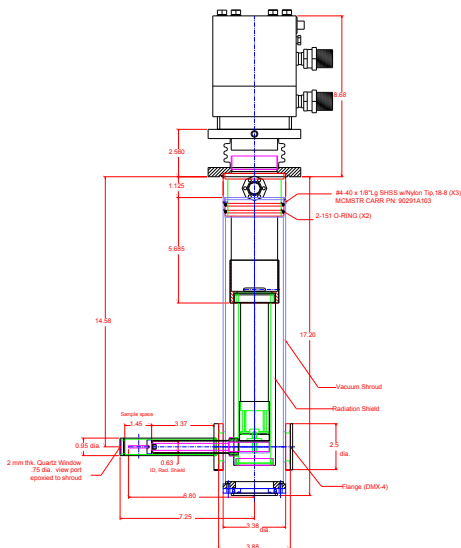

Low Vibration Side looking window can be placed in a MOKE, (Magneto Optical Kerr Effect). Sample can be located in any plane. The pole spacing can be as low as 1 inch.

Small diameter vacuum housing can be inserted into a narrow gap (high field). The optical window allows collection of light from the sample. The window can be very close to the sample for short focal length objective.