

iKon-XL 230

CCD

VERY LARGE AREA ASTRONOMY CCD

NEW

- ✓ -100 °C TE Cooling (ColdSpace™)
- ✓ NO liquid nitrogen or cryo-cooler
- ✓ 18-bit Extended Dynamic Range



Key Specifications

- 16.8 Megapixel sensor (CCD230-84)
- -100 °C TE cooled
- 3.8 e⁻ read noise
- 150,000 e⁻ well depth
- Up to 4 MHz readout (quad port)

INTRODUCING IKON-XL 230

Extreme performance, no hassle...

Andor's iKon-XL is a TE-cooled, very large area CCD camera platform, accommodating large field of view sensors that are ideally suited to long exposure astronomy applications. Patent-pending **ColdSpace™ technology** thermoelectrically cools a **back-illuminated 16.8 Megapixel** sensor (Teledyne e2v) down to **-100 °C**, avoiding the requirement for liquid nitrogen or unreliable cryo coolers. **Extended Dynamic Range technology** is complemented by up to **18-bit digitization**. Flexible connectivity is standard through either **USB 3.0** or a long distance **direct fibre optic** interface. iKon-XL is a **high quality, robust** and '**hassle-free**' detector solution, designed to operate with **low maintenance** and exceptional longevity, perfect for remote observing sites.

The iKon-XL 230 model uses the Teledyne e2v **CCD230-84** back-illuminated sensor, offering a very large **61.4 x 61.4 mm** imaging area from a 4096 x 4108 array format and 15 µm pixel size, ideal for applications such as Astronomy or X-ray/Neutron radiography.

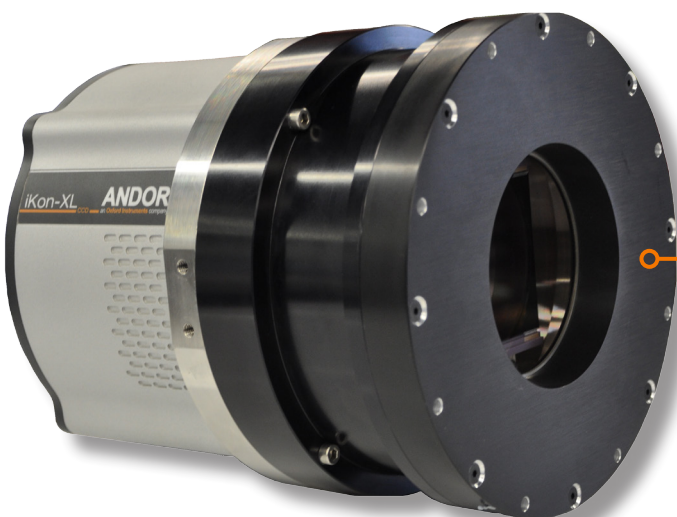

Low Maintenance Advantage

- ✓ **NO liquid nitrogen (LN₂)** – LN₂ cooled cameras require ready access to LN₂ supply and routine top up of LN₂ levels in order to hold temperature, as well as carrying an additional safety concern. Many observatories are in remote locations and in some cases unmanned, making LN₂ at best impractical, at worst impossible.
- ✓ **NO cryo cooler** – as many are already painfully aware, cryo coolers are cumbersome and notoriously unreliable. iKon-XL can reach typical cryo-cooled temperatures using only TE cooling and water supply.
- ✓ **No vacuum re-pumping** – the iKon-XL sensor enclosure design is based on Andor's proven, proprietary UltraVac™ process, which carries a Mean Time Between Failure (MTBF) value of > 100 years! Where other very large area CCD cameras require routine re-pumping, expect the iKon-XL to hold firm!
- ✓ **Field replaceable shutter** - No shutter is designed or specified for infinite usage! When it finally fails in a remote observing location, the shutter mounting of the iKon-XL has been purposefully designed such that the shutter can be easily replaced by the user on site.

FEATURES & BENEFITS

| Feature | Benefit |
|--|---|
| Thermoelectric Cooling to -100°C (Liquid/Water) | Patent-pending ColdSpace™ very large area TE cooling technology avoids need for liquid nitrogen or unreliable cryo coolers. Minimization of dark current to below the zodiacal background. |
| 61.4 x 61.4 mm sensor | Very large field of view from 16.8 Megapixel, 15 µm pixel pitch sensor |
| Extended Dynamic Range (18-bit) | Unique method to achieve low noise and high well depth within one scan. Supplemented by up to 18-bit digitization. |
| Peak QE over 95%*1 | High photon collection efficiency for maximizing SNR. |
| Low noise readout | Intelligent low-noise electronics offer the most 'silent' system noise available from the 230-84 sensor. |
| Ultravac™*2 | Critical for sustained vacuum integrity and to maintain unequalled cooling and QE performance, year after year (5 year vacuum warranty). |
| 'Deep Cooled' and 'Flexi' versions | 'Deep Cooled' for -100°C water/liquid (no air cooling). 'Flexi' for combined -80°C water/liquid or -60°C air cooled. |
| Fibre-optic or USB 3.0 interface flexibility | Built-in robust plug and play interface options as standard. Fibre optic for long distance solution. |
| Balanced Quad-port readout | Tracking stability to ensure all readout circuits experience same temperature and operating conditions. |
| Multiple readout speeds, up to 4 MHz | Slower readout for lowest noise, faster speeds for more rapid readout and focusing. |
| Field replaceable shutter | No shutter is designed or specified for infinite usage! When it finally fails in a remote observing location, it can be easily replaced on site. |
| IRIG-B GPS timestamp | Image GPS timestamp with 10ms resolution for network integration. |
| Fully Enclosed Casing (Deep Cooled model) | Reduced thermal bloom; minimal effect on nearby optics. |
| Easy reference column access | Easy and flexible software access to dark (shielded) reference columns. |
| Windows, Linux & Labview | Andor's user-friendly SDK supports both Windows and Linux OS. LabView VI package available. |
| ASTRO.control compatibility | Redlogix ASTRO.control is a dedicated platform for control of astronomical telescopes and instrumentation http://www.andor.com/astrocontrol.aspx |

Extended Dynamic Range Technology

CCD cameras always require software selection of amplifier gain to optimize either for low noise (weak signal) OR high well depth (bright signal). **Not both...**

...until now! iKon-XL utilizes proprietary Andor CCD expertise to offer **low read noise AND high well depth in one image**, with only one gain setting.

TECHNICAL DATA

System Specifications ^{*3}

| | | | |
|---|--|--------------------|--|
| Sensor Options | BV: CCD230-84 sensor, mid band AR coating BB: CCD230-84 sensor, broadband AR coating (blue optimized) | | |
| Pixels | 4096 (H) x 4108 (V) | | |
| Pixel size | 15 x 15 μ m | | |
| Image area | 61.4 x 61.4 mm with 100% fill factor | | |
| Minimum temperatures ^{*4} @ coolant temperature of 10°C @ coolant temperature of 16°C air cooled | Deep Cooled Model | Flexi Model | |
| | -100°C | -80°C | |
| | -95°C | -75°C | |
| | N/A | -60°C | |
| Blemish specification | Grade 1 sensor from supplier. | | |
| System window type | Single AR coated UV grade fused silica window (>98% transmission) | | |

Advanced Performance Specifications ^{*3}

| | | | | |
|---|---|---------------------|----------------------|----------------------|
| Dark Current, e⁻/pixel/sec ^{*5} @ -60°C @ -80°C @ -100°C (Deep Cooled Model only) | 0.0009 0.00009 0.00006 | | | |
| Active area pixel well depth (typical) | 150,000 e ⁻ | | | |
| Pixel readout rates | 0.1, 1, 2, 4 MHz | | | |
| Read Noise (e⁻) | 100 kHz 3.8 | 1 MHz 8.5 | 2 MHz 12.0 | 4 MHz 23.0 |
| Peak QE ^{*1} | >95% for BV models >87% for BB models | | | |
| Binning | User definable | | | |
| Region of Interest (windowing mode) | User definable (centred in 4-output mode) | | | |
| Linearity | Better than 99% | | | |
| Digitization | 16-bit (all speeds) 18-bit (100 kHz and 1 MHz) | | | |
| Outputs | Quad or Single | | | |
| Timestamp | IRIG-B GPS with 10 ms resolution | | | |

Frame Rates ^{*6}

| Readout Rate (Mhz) | Array size | | | |
|--------------------|-------------|-------------|-------------|-----------|
| | 4096 x 4112 | 2048 x 2048 | 1024 x 1024 | 512 x 512 |
| 4 | 0.437 | 0.658 | 0.877 | 1.050 |
| 2 | 0.288 | 0.474 | 0.695 | 0.909 |
| 1 | 0.181 | 0.319 | 0.512 | 0.736 |
| 0.1 | 0.023 | 0.044 | 0.086 | 0.160 |

| Binning | Readout rate (MHz) | | | |
|---------|--------------------|------|------|------|
| | 4 | 2 | 1 | 0.1 |
| 1x1 | 0.44 | 0.29 | 0.18 | 0.02 |
| 2x2 | 0.66 | 0.55 | 0.43 | 0.04 |
| 4x4 | 0.88 | 0.82 | 0.73 | 0.09 |
| 8x8 | 1.05 | 1.03 | 0.99 | 0.16 |
| 16x16 | 1.17 | 1.16 | 1.14 | 0.28 |

Quantum Efficiency Curve *1

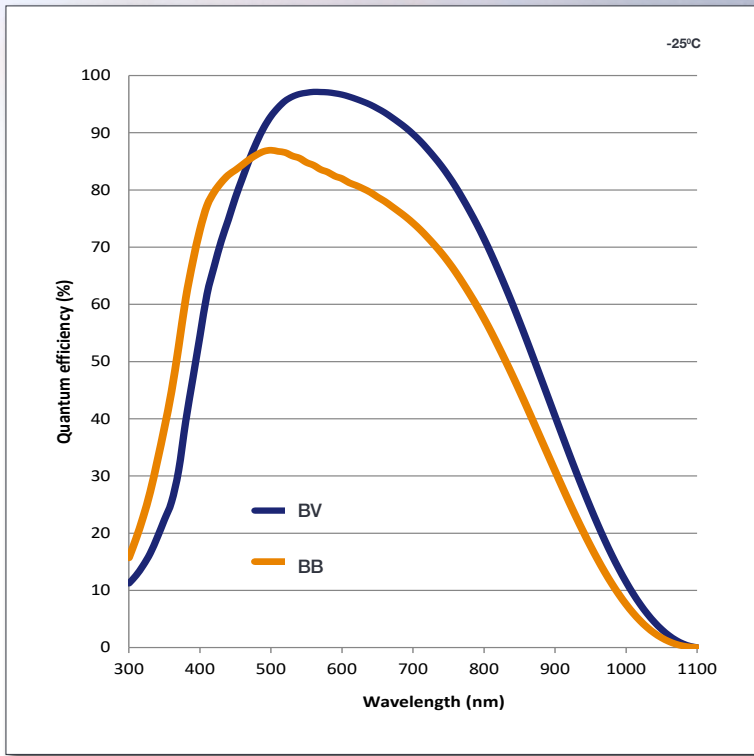

The iKon-XL 230 is available with 2 sensor options:

- **BV:** Mid-band AR coating (providing exceptionally high QE in the visible range)
- **BB:** Broadband AR coating (providing enhanced sensitivity in the blue region)

Flexible Connectivity

- 1 USB 3.0**
USB 3.0 offers a robust high speed plug and play data interface
- 2 TTL / Logic**
Connector type: SMB, provided with SMB - BNC cable
Fire (Output), External Trigger (Input), Shutter (Output)
- 3 I²C**
Compatible with Fischer SC102A054-130
Shutter (TTL), I²C Clock, I²C Data, +5 Vdc, Ground
- 4 Fibre Optic**
Long distance connection via LC Fibre-optic I/O connection
- 5 IRIG-B**
Compatible with IRIG-B standard (GPS with 10 ms resolution)
- W Water Cooling**
Connection to recirculator or other water/liquid cooling system
- P Power**
Connection to Camera Control Unit (supplied) refer to power requirements on page 8

Notes:

Minimum cable clearance required at rear of camera 150 mm



CREATING THE OPTIMUM PRODUCT FOR YOU



XL- EA01 - D S example shown

Step 1. Choose the sensor type option

| Description | Code |
|--|------|
| 16.8 Megapixel CCD230-84 Back Illuminated Sensor. BV: Mid-band AR coating | EA01 |
| 16.8 Megapixel CCD230-84 Back Illuminated Sensor. BB: Broadband AR coating | EA02 |

Step 2. Choose the cooling option

| Description | Code |
|---|------|
| Flexi Cooling model (max. cooling -80°C @ coolant temp of 10°C; -60°C max. with air cooling) | C |
| Deep Cooled model (max. cooling -100°C @ coolant temp of 10°C) | D |

Step 3. Select shutter option

| Description | Code |
|--|-------|
| With Standard Shutter (For use between 0°C and +30°C ambient temperatures) | S |
| With Extended Range Shutter (For use between -30°C and +30°C ambient temperatures) | S-EXT |
| Without Shutter | 0 |

Step 4. Select the required accessories

| Description | Code |
|---|-------------------------|
| Replacement 'standard' shutter unit for the iKon-XL. For use between 0°C and +30°C ambient temperatures. | XL-SH-STD |
| Replacement 'extended temperature range' shutter unit for the iKon-XL. For use between -30°C and +30°C ambient temperatures. | XL-SH-EXT |
| 15 m camera cable with straight attachment for the CCU-500A (iKon-XL Flexi model) If this is ordered it will be provided <i>instead</i> of the standard 5 m cable. | XL-F-CAB-ST-15M |
| 15 m camera cable with straight attachment for the CCU-500B (iKon-XL Deep Cooled model) If this is ordered it will be provided <i>instead</i> of the standard 5 m cable. | XL-DC-CAB-ST-15M |
| 25 m fibre optic cable, LC-LC patch lead OM2 (Standard supplied fibre is 15 m). | FIBR-25M |
| 100 m fibre optic cable, LC-LC patch lead OM3 (Standard supplied fibre is 15 m). | FIBR-100M |
| Hard shell protective transport case for the iKon-XL Flexi model. Tailored to dimensions of the iKon-XL Flexi model for secure transport to and from observing sites. | XL-F-TRANS-CASE |
| Hard shell protective transport case for the iKon-XL Deep Cooled model. Tailored to dimensions of the iKon-XL Deep Cooled model for secure transport to and from observing sites. | XL-DC-TRANS-CASE |

Please contact your local sales representative regarding other options such as different mounting types, camera window options or other customizations you may require for system integration or your specific application.

Step 5. Select the required software

The iKon-XL requires at least one of the following software options:

Solis for Imaging A 32-bit and fully 64-bit enabled application for Windows (7, 8, 8.1 and 10) offering complete functionality for data acquisition and processing. AndorBasic provides macro language control of data acquisition, processing, display and export.

Andor SDK A software development kit that allows you to control the Andor range of cameras from your own application. Available as 32/64-bit libraries for Windows (7, 8, 8.1 and 10), compatible with C/C++, C#, Delphi, VB.NET, LabVIEW and Matlab. Linux SDK compatible with C/C++.

Third party software compatibility Drivers are available so that the iKon-XL can be operated through a large variety of third party imaging packages. See Andor web site for detail: <http://www.andor.com/software/>

MECHANICAL DRAWINGS

Dimensions in mm

Deep Cooled Model

8 OFF
M5 TAPPED HOLES
X 20 DEEP
ON 189 PCD

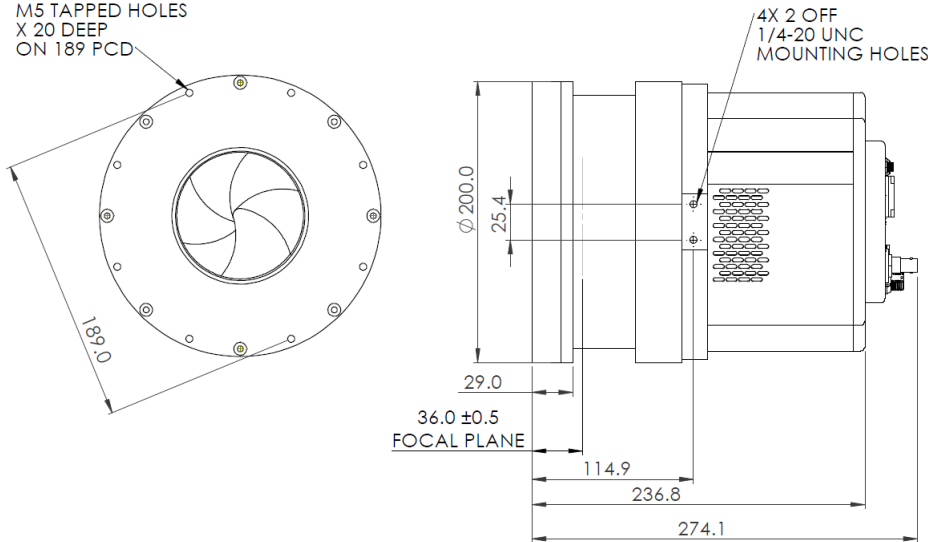

Weight (approx): 12 Kg [26 lbs 7]

Flexi Model

8 OFF
M5 TAPPED HOLES
X 20 DEEP
ON 189 PCD

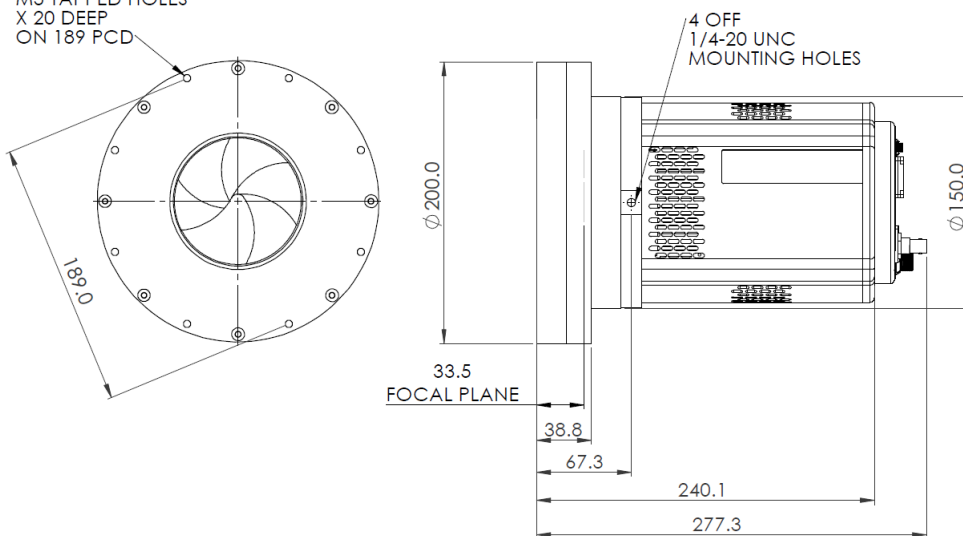

Weight (approx): 8.25 Kg [18lbs 3]

Camera Control Unit CCU-500 *7

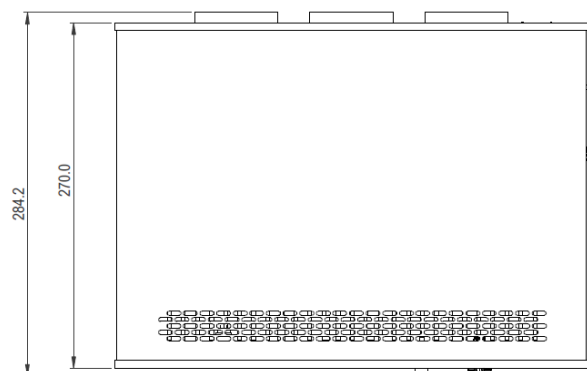
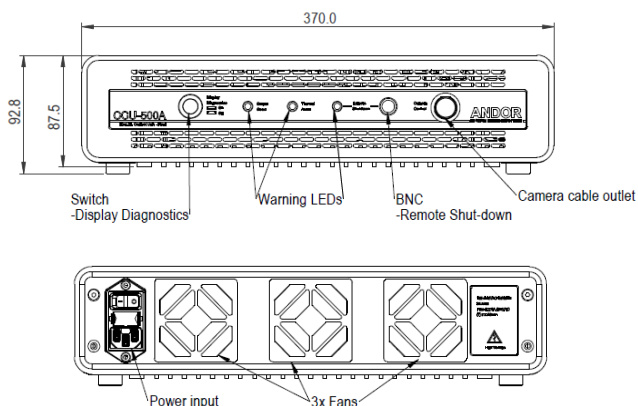

Note: Product drawings of models without shutter can be found at <http://www.andor.com/xl-product-drawings>

Weight (approx): 6.6 Kg [14 lbs 5]

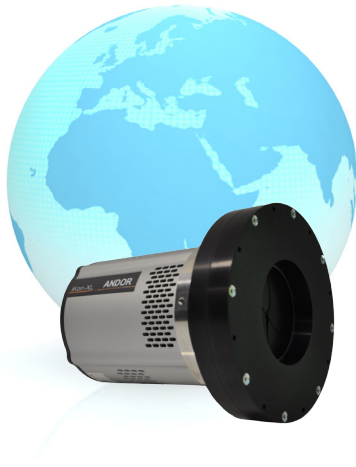

ORDER TODAY

Need more information? At Andor we are committed to finding the correct solution for you. With a dedicated team of technical advisors, we are able to offer you one-to-one guidance and technical support on all Andor products. For a full listing of our regional sales offices, please see: andor.com/contact

Our regional headquarters are:

Europe

Belfast, Northern Ireland
Phone +44 (28) 9023 7126
Fax +44 (28) 9031 0792

Japan

Tokyo
Phone +81 (3) 6732 8968
Fax +81 (3) 6732 8939

North America

Concord, MA, USA
Phone +1 (860) 290 9211
Fax +1 (860) 290 9566

China

Beijing
Phone +86 (10) 8271 9066
Fax +86 (10) 8271 9055

Items shipped with your camera

- 1x Fibre Optic PCIe card
 - 1x USB 3 PCIe card
 - 1x iKon-XL camera control unit *
 - 1x Camera power lead (5m)
 - 3x BNC-SMA cable (2m)
 - 1x USB 3.0 cable (3m)
 - 1x Fibre Optic lead (15m)
 - 1x QuickStart Guide
- (Note: PC requires 1x slot for installation of a PCIe card)

Footnotes

1. Quantum efficiency as supplied by the sensor manufacturer.
2. Assembled in a state-of-the-art facility, Andor's UltraVac™ vacuum process combines a permanent hermetic vacuum seal (no o-rings), with a stringent protocol and proprietary materials to minimize outgassing. Outgassing is the release of trapped gases that would otherwise degrade cooling performance and potentially cause sensor failure.
3. Figures are typical, unless otherwise stated.
4. Specified minimum temperature with coolant assumes coolant temperature of 10°C or 16°C, measured at camera head. Note that cooling performance may be affected by distance between camera head and cooler.
5. Dark current measurement is averaged over the CCD area, excluding any regions with blemishes.
6. The frame rates shown are for a range of binning or array size combinations. All measurements are made with 179 µs vertical shift speed and using the quad output. It also assumes internal trigger mode of operation and minimum exposure time
7. Camera Control Unit (CCU-500) supplied with brackets for 19 inch rack mounting and mounting lugs for securing to optical tables.



Minimum Computer Requirements:

- 3.0 GHz single core or 2.4 GHz dual or quad core processor
- 2 GB RAM
- 250 MB free hard disc to install software (at least 1 GB recommended for data spooling)
- USB 3.0 High Speed host Controller capable of sustained rate of 60 MB/s
- Windows (7, 8, 8.1 and 10) or Linux

Operating & Storage Conditions:

- Operating Temperature: 0°C to +30°C ambient (-30°C to +30°C using extended range shutter)
- Operating Altitude: up to 6000m
- Relative Humidity: <70% (non-condensing)
- Storage Temperature: -30°C to 50°C

Power Requirements:

- 100 - 240 VAC, 50/60 Hz
- Power consumption:
Flexi models: Camera Head (inc.External Power Supply) 240V/100V (Typ.): 165/180 W
Deep Cooled models: Camera Head (inc. External Power Supply) 240V/100V (Typ): 465/480 W



Windows is a registered trademark of Microsoft Corporation.
Labview is a registered trademark of National Instruments.
Matlab is a registered trademark of The MathWorks Inc.