

MASS VIEW

带显示功能的气体质量流量计-完美替代传统VA流量计

> 简介

Bronkhorst[®], 低流量测量和控制专家, 研发了一系列创新的集成显示质量流量计、调节器和控制器。MASS-VIEW[®]系列为转子流量计或浮子流量计(VA流量计)提供现代、新颖、经济型的替代方案。不同于传统的VA流量计, 这些新型的流量计测量质量流量, 而非体积流量。作为VA流量计的更新换代MASS-VIEW[®]的机械结构提供现行市场上最常见的接头选择, 以供匹配。

> MASS-VIEW[®] 系列热式质量流量计

Bronkhorst设计的MASS-VIEW[®]系列仪表基于直接热式质量流量测量(无旁路)原理。使用这种类型传感器的一大优点是仪器直接测量质量流量, 无需温度和压力校正。与传统VA流量计相比, 其他优点是通过消除流路中的玻璃部件, 具有更高的精度、更宽的量程比(高达1:100)、无视差偏差和更加安全的构造。MASS-VIEW[®]质量流量计可用于满量程范围0.05至500 l_v/min (等值空气), 压力等级为10 bar(g)或150 psi(g)。自带明亮的广角OLED显示屏, 能够清晰地读取实际流量(数值和柱形图)、总流量和气体类型。

显示功能可以通过易于操作的界面, 使用四向导航按钮轻松设置。预装的气体曲线消除了对不同气体进行重复校准的需求, 从而降低成本。附加的特性和功能包括各种报警和计数器功能、模拟输出信号、数字接口和两个继电器触点。流量控制可通过可选的针型阀实现。这些高质量的针型阀可以平稳精准地调节气体流量。

最新一代MASS-VIEW[®] 产品线的最大革新是加入一个集成的自动补偿控制器。所需流量通过针型阀按照常规方式设定, 任何上游压力变化可自动得到补偿, 以确保稳定的恒定流量。

> MASS-VIEW[®] 特征

- ◆ 清晰显示:
 - 实际流量 (柱形图和数值)
 - 所需流量单位
 - 气体类型
 - 累计流量
- ◆ 明亮的广角OLED显示屏
- ◆ 无视差偏差
- ◆ 受压力和温度影响小
- ◆ 低差压
- ◆ 流量范围大
- ◆ 快速响应
- ◆ 高精度
- ◆ 信号输出, 模拟量(0 ... 5 Vdc)和数字接口

> 数字特性

- ◆ RS232接口和Modbus ASCII/RTU通讯
- ◆ 可配置密码保护
- ◆ 报警和计数器功能
- ◆ 多气体/多量程范围
- ◆ 预配置的气体
- ◆ 数字校准
- ◆ 免费的Bronkhorst软件工具



> 技术参数

性能	
精度	: ± 2% RD for flow > 50% of max. capacity; ± (1% RD + 0.5% FS) on lower flows
重复性	: < 0.2% FS typical < 0.6% FS typical for MV-108 / MV-308
预配置气体	: Air, Ar, N ₂ , O ₂ , CO ₂ , CH ₄ , C ₃ H ₈ , N ₂ O, CO and C ₄ H ₁₀ Air, N ₂ , O ₂ , CO (models MV-101, MV-301 and MV-401) (special models available for H ₂ and Helium)
控制器	: Use a clean and dry gas, filter recommended
标准标定气体	: Air, other gases are converted using our Fluidat® conversion model which will introduce extra inaccuracy
量程比	: up to 1:100
操作压力	: 0 ... 10 bar(g) / 0 ... 150 psi(g)
压力系数	: ± 0.2% RD/bar typical at Air
操作温度	: 0 ... 50°C (32 ... 122°F)
温度系数	: Zero: <0.1% FS/°C, Span: <0.2% RD/°C
方位影响度	: < 0.1% FS
响应时间 (t _{63%})	: 2 s
控制器	
最小Δp	: 1 bar(d) (for models MV-4x5 2 bar(d))
最大Δp	: 7 bar(d)
控制精度	: Less than 0,5-1% RD/bar
机械规格	
材质	: Meter: aluminium, Viton® (接液部件) Needle valve: SS316, Viton®, PTFE; (for models MV-3x2 and MV-4xx: Fluorosint®, Brass, Buna N) Controller: membrane Fiber-reinforced nitrile
气体连接 (in/out)	: G 1/4" BSPP female thread G 1/2" BSPP female thread for MV-108 / MV-308 (compression fittings optional)
重量	: meter/regulator: 0.7 kg controller: 1.4 kg MV-108 / MV-308: 0.8 kg
电气规格	
电气连接	: 8-pin RJ-45 modular jack
输出	: analog: 0 ... 5 Vdc digital: RS232 / RS485 (Modbus ASCII/RTU)
电源电压	: 15 ... 24 Vdc (+/-10%)
功耗	: approx. 135 mA
最小和最大继电器触点	: switching current 0.5 A, 24 Vdc, one side grounded (0 Vdc power)
安全性	
压力测试	: 21 bar(a) / 300 psi(a)
防护等级	: IP-50
EMC	: EU declaration
质保期	
所有仪表及配件自出厂日起质保3年。	
技术参数如有变更, 恕不另行通知。	

> 选型表

MV	-	N	N	N	-	AA
Base		Max. capacity (air)				
1	Meter	1	200 ml _l /min			
3	Regulator	2	2000 ml _l /min			
4	Controller	4	20 l _l /min			
		5	50 l _l /min			
		6	200 l _l /min			
		8	500 l _l /min			
Pre-installed gases		Special gases				
0	Standard	H2				
9	Non standard	HE				

> 尺寸

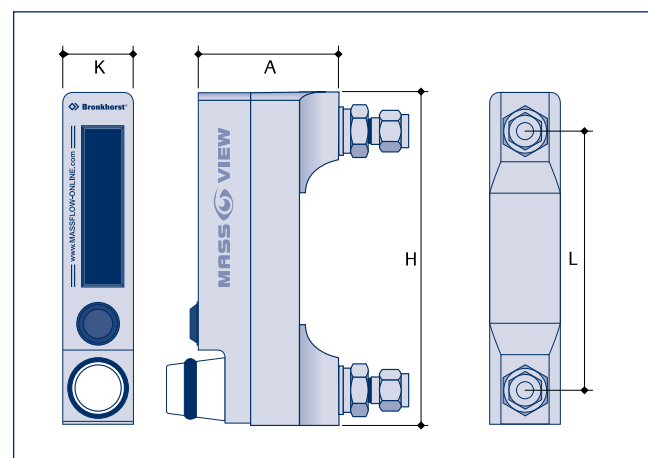

Model	A	H	K	L
MV-101/102/104/106/191/192/194/196	63	159	38	114
MV-108	75	159	38	114
MV-301/302/304/306/391/392/394/396	63	159	38	114
MV-308	75	159	38	114

Dimensions in mm.

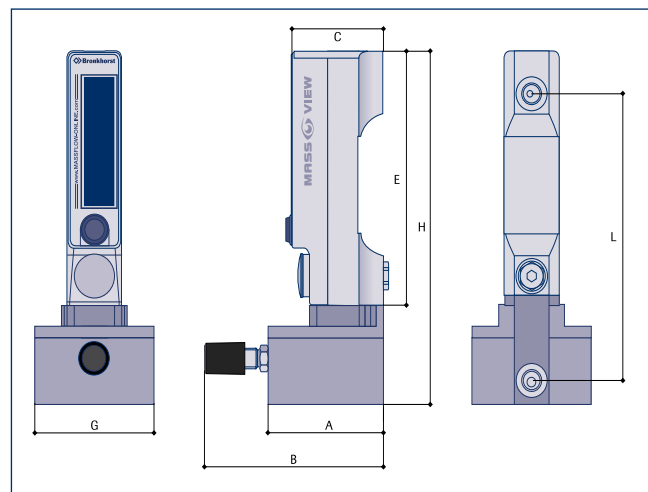

Model	A	B	C	E	G	H	L
MV-401/402/404/405	79	123	63	159	81.5	221	179

Dimensions in mm.

> 可选适配器 (进口和出口)

Metric sizes	Inch sizes
3 mm OD compression type	1/8" OD compression type
6 mm OD compression type	1/4" OD compression type
12 mm OD compression type	1/2" OD compression type

> 电气连接

连接图

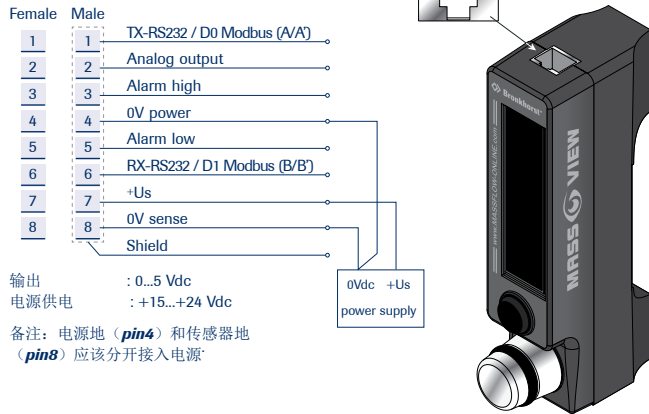

> 电缆的选择

用于分别连接电源和I/O信号的组合。

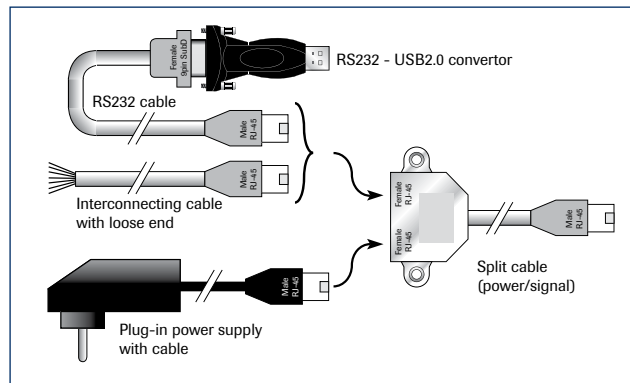

> 配件

以下配件可供选配MASS-VIEW®仪表。

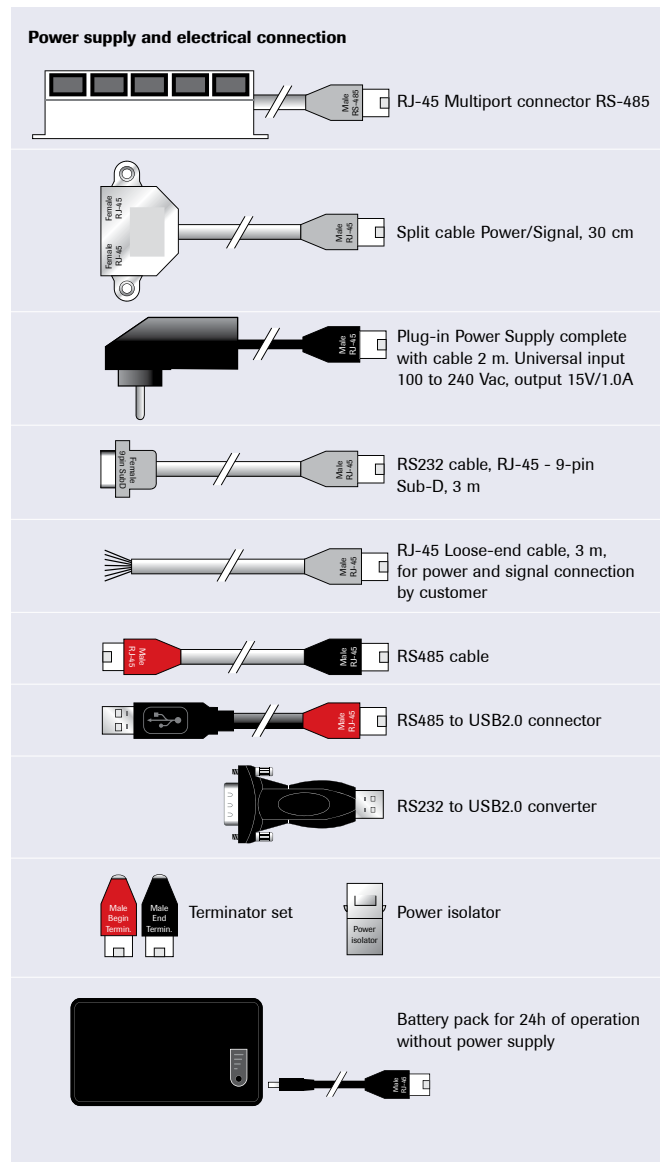

典型案例-7个带RS485 - USB信号连接的MASS-VIEW流量计/调节器。因为一个PiPS-MV的最大电源为15 W，所以该案例中需要两个分离的电源模块。

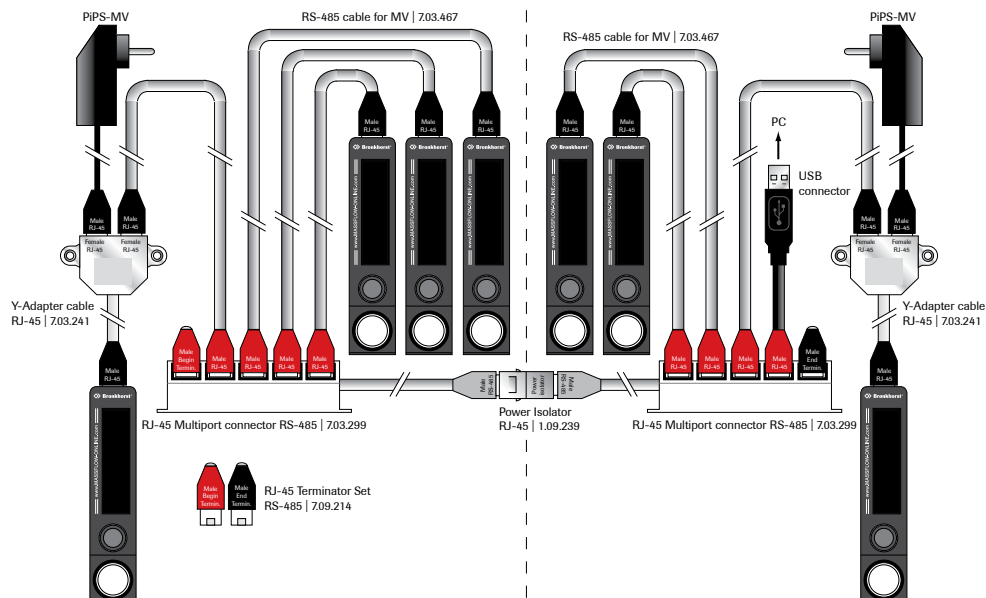

> 量程范围

Selectable ranges in I_p /min (SLM)	Air	N ₂	O ₂	CO	Ar	CO ₂	CH ₄	C ₃ H ₈	N ₂ O	C ₄ H ₁₀
MV-101, MV-301										
Range 1 (max.)	0.01 ... 0.2	0.01 ... 0.2	0.01 ... 0.2	0.01 ... 0.2	-	-	-	-	-	-
Range 2	0.01 ... 0.1	0.01 ... 0.1	0.01 ... 0.1	0.01 ... 0.1	-	-	-	-	-	-
Range 3 (min.)	0.01 ... 0.05	0.01 ... 0.05	0.01 ... 0.05	0.01 ... 0.05	-	-	-	-	-	-
MV-102, MV-302										
Range 1 (max.)	0.02 ... 2	0.02 ... 2	0.02 ... 2	0.02 ... 2	0.04 ... 4	0.02 ... 2	0.01 ... 1	0.01 ... 1	0.02 ... 2	0.01 ... 1
Range 2	0.02 ... 1	0.02 ... 1	0.02 ... 1	0.02 ... 1	0.04 ... 2	0.02 ... 1	0.01 ... 0.5	0.01 ... 0.5	0.02 ... 1	0.01 ... 0.5
Range 3	0.02 ... 0.5	0.02 ... 0.5	0.02 ... 0.5	0.02 ... 0.5	0.04 ... 1	0.02 ... 0.5	0.01 ... 0.2	0.01 ... 0.2	0.02 ... 0.5	0.01 ... 0.2
Range 4 (min.)	0.02 ... 0.2	0.02 ... 0.2	0.02 ... 0.2	0.02 ... 0.2	0.04 ... 0.5	0.02 ... 0.2	0.01 ... 0.1	0.01 ... 0.1	0.02 ... 0.2	0.01 ... 0.1
MV-104, MV-304										
Range 1 (max.)	0.2 ... 20	0.2 ... 20	0.2 ... 20	0.2 ... 20	0.4 ... 40	0.2 ... 20	0.1 ... 10	0.1 ... 10	0.2 ... 20	0.1 ... 10
Range 2	0.1 ... 10	0.1 ... 10	0.1 ... 10	0.1 ... 10	0.2 ... 20	0.1 ... 10	0.01 ... 0.5	0.05 ... 5	0.1 ... 10	0.05 ... 5
Range 3	0.05 ... 5	0.05 ... 5	0.05 ... 5	0.05 ... 5	0.1 ... 10	0.05 ... 5	0.01 ... 0.2	0.02 ... 2	0.05 ... 5	0.02 ... 2
Range 4 (min.)	0.04 ... 2	0.04 ... 2	0.04 ... 2	0.04 ... 2	0.08 ... 5	0.04 ... 2	0.01 ... 0.1	0.02 ... 1	0.04 ... 2	0.02 ... 1
MV-106, MV-306										
Range 1 (max.)	2 ... 200	2 ... 200	2 ... 200	2 ... 200	4 ... 400	2 ... 200	1 ... 100	1 ... 100	2 ... 200	1 ... 100
Range 2	1 ... 100	1 ... 100	1 ... 100	1 ... 100	2 ... 200	1 ... 100	0.5 ... 50	0.5 ... 50	1 ... 100	0.5 ... 50
Range 3	0.5 ... 50	0.5 ... 50	0.5 ... 50	0.5 ... 50	1 ... 100	0.5 ... 50	0.2 ... 20	0.2 ... 20	0.5 ... 50	0.2 ... 20
Range 4 (min.)	0.4 ... 20	0.4 ... 20	0.4 ... 20	0.4 ... 20	0.8 ... 50	0.4 ... 20	0.2 ... 10	0.2 ... 10	0.4 ... 20	0.2 ... 10
MV-108, MV-308										
Range 1 (max.)	5 ... 500	5 ... 500	5 ... 500	5 ... 500	10 ... 1000	5 ... 500	2.5 ... 250	2.5 ... 250	5 ... 500	2.5 ... 250
Range 2	2 ... 200	2 ... 200	2 ... 200	2 ... 200	5 ... 500	2 ... 200	1.25 ... 125	1.25 ... 125	2 ... 200	1.25 ... 125
Range 3	1 ... 100	1 ... 100	1 ... 100	1 ... 100	2 ... 200	1 ... 100	0.625 ... 62.5	0.625 ... 62.5	1 ... 100	0.625 ... 62.5
Range 4 (min.)	1 ... 50	1 ... 50	1 ... 50	1 ... 50	2 ... 100	1 ... 50	0.5 ... 25	0.5 ... 25	1 ... 50	0.5 ... 25
MV-401										
Range 1 (max.)	0.02 ... 0.2	0.02 ... 0.2	0.02 ... 0.2	0.02 ... 0.2	-	-	-	-	-	-
Range 2	0.02 ... 0.1	0.02 ... 0.1	0.02 ... 0.1	0.02 ... 0.1	-	-	-	-	-	-
Range 3 (min.)	0.02 ... 0.05	0.02 ... 0.05	0.02 ... 0.05	0.02 ... 0.05	-	-	-	-	-	-
MV-402										
Range 1 (max.)	0.02 ... 2	0.02 ... 2	0.02 ... 2	0.02 ... 2	0.04 ... 4	0.02 ... 2	0.01 ... 1	0.01 ... 1	0.02 ... 2	0.01 ... 1
Range 2	0.02 ... 1	0.02 ... 1	0.02 ... 1	0.02 ... 1	0.04 ... 2	0.02 ... 1	0.01 ... 0.5	0.01 ... 0.5	0.02 ... 1	0.01 ... 0.5
Range 3	0.02 ... 0.5	0.02 ... 0.5	0.02 ... 0.5	0.02 ... 0.5	0.04 ... 1	0.02 ... 0.5	0.01 ... 0.2	0.01 ... 0.2	0.02 ... 0.5	0.01 ... 0.2
Range 4 (min.)	0.02 ... 0.2	0.02 ... 0.2	0.02 ... 0.2	0.02 ... 0.2	0.04 ... 0.5	0.02 ... 0.2	0.01 ... 0.1	0.01 ... 0.1	0.02 ... 0.2	0.01 ... 0.1
MV-404										
Range 1 (max.)	0.2 ... 20	0.2 ... 20	0.2 ... 20	0.2 ... 20	0.4 ... 20	0.2 ... 20	0.1 ... 10	0.1 ... 10	0.2 ... 20	0.1 ... 10
Range 2	0.1 ... 10	0.1 ... 10	0.1 ... 10	0.1 ... 10	0.2 ... 20	0.1 ... 10	0.01 ... 0.5	0.05 ... 5	0.1 ... 10	0.05 ... 5
Range 3	0.05 ... 5	0.05 ... 5	0.05 ... 5	0.05 ... 5	0.1 ... 10	0.05 ... 5	0.01 ... 0.2	0.02 ... 2	0.05 ... 5	0.02 ... 2
Range 4 (min.)	0.04 ... 2	0.04 ... 2	0.04 ... 2	0.04 ... 2	0.08 ... 5	0.04 ... 2	0.01 ... 0.1	0.02 ... 1	0.04 ... 2	0.02 ... 1
MV-405										
Range 1 (max.)	0.5 ... 50	0.5 ... 50	0.5 ... 50	0.5 ... 50	-	-	-	-	-	-
Range 2	0.2 ... 20	0.2 ... 20	0.2 ... 20	0.2 ... 20	-	-	-	-	-	-
Range 3	0.1 ... 10	0.1 ... 10	0.1 ... 10	0.1 ... 10	-	-	-	-	-	-
Range 4 (min.)	0.05 ... 5	0.05 ... 5	0.05 ... 5	0.05 ... 5	-	-	-	-	-	-

> H₂和He的量程范围

Selectable ranges in I_p /min (SLM)	H ₂
MV-191-H2, MV-391-H2	
Range 1 (max.)	0.02 ... 0.2
Range 2	0.02 ... 0.1
Range 3	0.02 ... 0.05
MV-192-H2, MV-392-H2	
Range 1 (max.)	0.05 ... 1
Range 2	0.05 ... 0.5
Range 3	0.05 ... 0.2
Range 4 (min.)	0.05 ... 0.1
MV-194-H2, MV-394-H2	
Range 1 (max.)	0.1 ... 10
Range 2	0.1 ... 5
Range 3	0.1 ... 2
Range 4 (min.)	0.1 ... 1
MV-196-H2, MV-396-H2	
Range 1 (max.)	1 ... 100
Range 2	0.5 ... 50
Range 3	0.2 ... 20
Range 4 (min.)	0.2 ... 10

Selectable ranges in I_p /min (SLM)	He
MV-191-HE, MV-391-HE	
Range 1 (max.)	0.02 ... 0.2
Range 2	0.02 ... 0.1
Range 3	0.02 ... 0.05
MV-192-HE, MV-392-HE	
Range 1 (max.)	0.05 ... 2
Range 2	0.05 ... 1
Range 3	0.05 ... 0.5
Range 4 (min.)	0.05 ... 0.2
MV-194-HE, MV-394-HE	
Range 1 (max.)	0.2 ... 20
Range 2	0.1 ... 10
Range 3	0.1 ... 5
Range 4 (min.)	0.1 ... 2
MV-196-HE, MV-396-HE	
Range 1 (max.)	1 ... 100
Range 2	0.5 ... 50
Range 3	0.2 ... 20
Range 4 (min.)	0.2 ... 10

> 应用

MASS-VIEW®在各种不同领域的应用:

- ◆ 燃烧器控制 (炉结构)
- ◆ 焊接 (焊接气体监测)
- ◆ 泄漏测试 (质量、环境)
- ◆ 镀膜 (设备施工)
- ◆ 气体环境调控 (生物技术)
- ◆ 气体消耗测量 (医院)
- ◆ 检测设备 (生产维护)
- ◆ 气体混合物现场制备
- ◆ 流量监测 (实验室)
- ◆ 切割 (钢板)
- ◆ 成本中心计费
- ◆ 分析仪器
- ◆ 曝气 (食品、冰激凌/食用油)
- ◆ 保护气 (食物)
- ◆ 发酵 (食品、生物技术、制药)



> Bronkhorst® FlowWare, 免费软件工具

Bronkhorst提供如下软件以支持用户在个人电脑中安装和操作:

FlowDDE : 数字仪表和MS Windows软件之间的接口软件工具

FlowPlot : 监测和优化数字仪表参数的软件工具

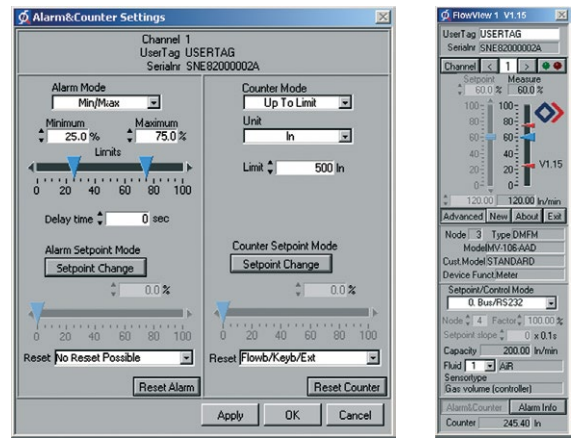

FlowView : 用于操作Bronkhorst数字仪表的软件工具

> 显示菜单按钮

四向导航按钮提供了易于用户操作的界面, 可轻松设置例如归零功能、选择预安装列表中的预安装气体、单位设置、报警功能(最小值/最大值/计数限制值)和计数器功能。提供密码保护以防止未经授权的更改。更多功能介绍请见下图MASS-VIEW®菜单功能概览。

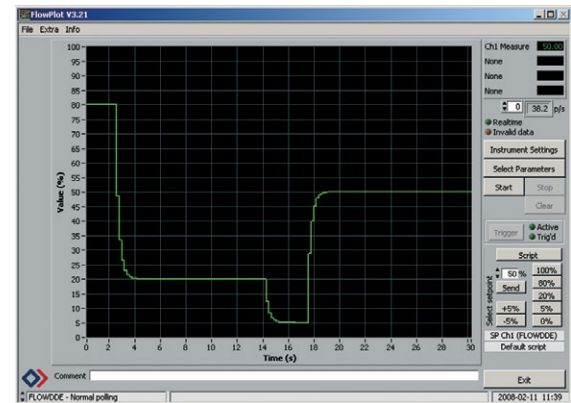

这些软件工具可供我们MASS-VIEW®系列和其他Bronkhorst数字仪表用户免费使用, 可通过<http://www.massflow-online.com>下载。

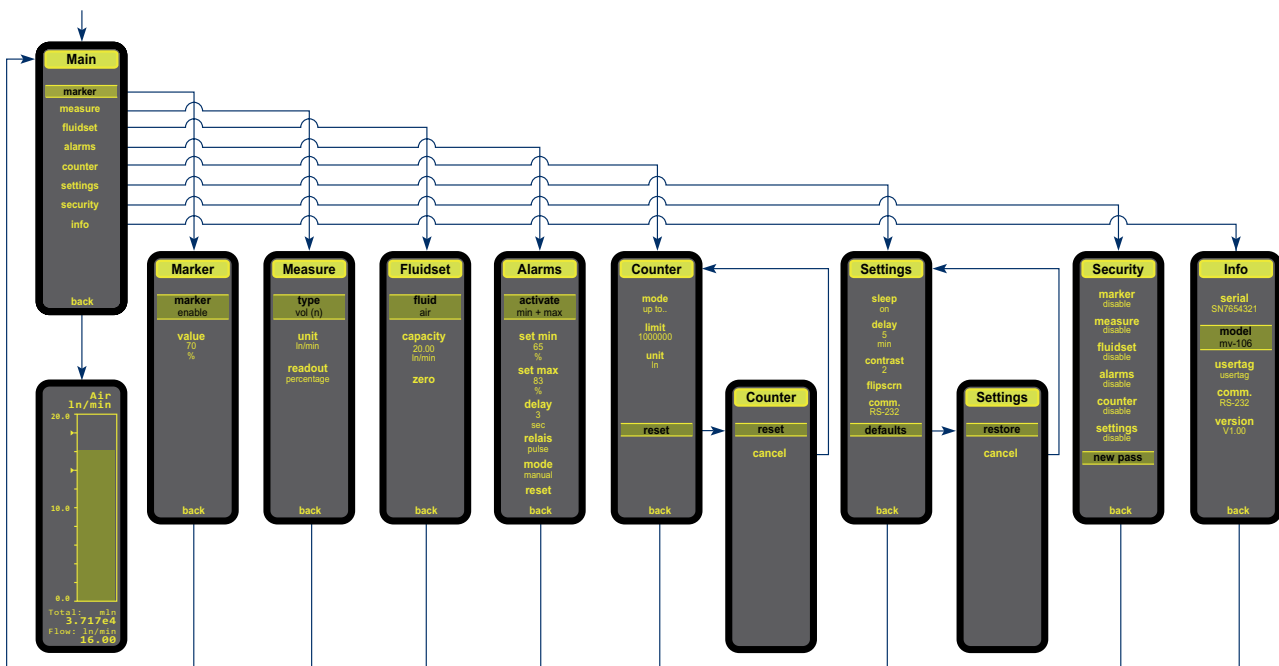

Mass Flow ONLINE

Flow Meters / Regulators / Controllers

MASS VIEW

Thermal Mass Flow Meters, Regulators & Controllers for gases



- > Bright, wide-angle OLED display
- > Flow ranges: from 10 ... 200 ml_n/min (sccm) up to 2 ... 500 l_n/min (SLM) (air equivalent)
- > Output: RS232, Modbus/RS485 or analog
- > Multi Gas / Multi Range (10 pre-installed gases)

MAG VIEW

Electromagnetic flowmeters for liquids



- > Insensitive to contaminated liquids
- > No mechanical wear
- > Fast response
- > Flow ranges from 0.1 ... 2 l/min up to 5 ... 250 l/min

SONIC VIEW

Ultrasonic flow sensor for measuring water and aqueous solutions



- > No mechanical wear
- > Just one chemically resistant wetted part (stainless steel)
- > Flow ranges from 1,5 ... 30 l/h up to 5 ... 110 l/min

FUEL VIEW

Fuel consumption and operating time meter with electronic counter



- > Built-in fuel filter
- > Suitable for Diesel, heating fuel, engine oil and other comparable liquids
- > Flow ranges from 1 ... 50 l/h up to 10 ... 500 l/h

FLOW ADJUST

Standard and high resolution manual control valves for extremely precise control in low flow

Standard Resolution

- > Compact needle valve in aluminium housing
- > 7-turn standard resolution flow adjustment
- > Valve knob included for easy adjustment
- > Two M4 female threads for solid fixation
- > Suitable for gases and liquids
- > Leak-free valve

High Resolution (additional to SR)

- > Non-rotating stainless steel valve pin
- > Valve pin o-ring guarantees positive shut-off without stem damage
- > Self-lubricating orifice liner assures long life
- > smooth, non-reversing flow characteristics and 15-turn high resolution



LIQUI VIEW Base

Vortex meter for monitoring low viscosity, water-like liquids



- > No moving parts
- > Smart and lightweight
- > Low pressure drop
- > Wide flow ranges
- > Fast response
- > Suitable for dirty water
- > Sustainable product design

Factory

Bronkhorst® in China



Bronkhorst High-Tech B.V., Nijverheidsstraat 1a,
NL-7261 AK Ruurlo, The Netherlands
E info@bronkhorst.com | www.bronkhorst.com

SHANGHAI
Bronkhorst中国全资子公司
布琅轲德特(上海)测量设备贸易有限公司
地址: 上海徐汇区田州路99号新安大厦1001室
电话: +86 21 6090 7259 热线: 400 110 7259
邮箱: sales@bronkhorst.cn
网址: www.bronkhorst.cn
致力于国际客户的Bronkhorst产品销售及服务工作



Bronkhorst中国授权经销商
北京阿蒂姆控制设备有限公司
地址: 北京市朝阳区融科望京中心A座309~310室
电话: +86 10 6471 9268/9269/9293
邮箱: info@atm-china.com
网址: www.atm-china.com
致力于本土客户的Bronkhorst产品销售及服务工作