

NETZSCH

Proven Excellence.



Thermal Analysis – Mass Spectrometer Capillary Coupling

Evolved Gas Analysis
Method, Techniques and Applications

Analyzing & Testing

Thermal Analysis and Evolved Gas Analysis

Thermoanalytical Techniques

Thermoanalytical techniques are universal tools for characterizing solids and liquids with respect to their thermal behavior. Especially Thermogravimetry and Simultaneous Thermal Analysis (STA, TGA-DTA/DSC) find broad application in testing the weight changes of a sample during a programmed heat treatment. This yields a multitude of information on material properties, composition and stability.

However, chemical and analytical information about the products causing the weight changes to the sample is often lacking. Evolved Gas Analysis (EGA) by such techniques as quadrupole mass spectrometry can supply this additional information.



Application Fields for Thermal Analysis Coupled to Mass Spectrometry

Decomposition

- Dehydration
- Stability
- Residual solvent
- Pyrolysis

Solid-Gas Reactions

- Combustion
- Oxidation
- Adsorption
- Desorption
- Catalysis

Compositional Analysis

- Polymer content
- Proximate analysis
- Binder burnout
- Dewaxing
- Ash content

Identification

- Gas composition
- Fingerprint
- Partial pressure
- Fragmentation
- Solid-gas interactions

Evaporation

- Vapor pressure
- Sublimation

QMS 403 Aëolos Quadro

Reasons to Couple a Thermal Analyzer to a Mass Spectrometer

Complementary Information

Mass changes detected by thermal analysis can be explained by gas analysis in the mass spectrometer; coupling thus creates a workstation for analytical chemistry. Evolved species are detected down to the ppm level in mass spectrometry, which exceeds the standard sensitivity of thermal analysis methods. The coupling of the two therefore allows for top-notch material research and characterization.

Quadrupole Mass Spectrometry (QMS)

A quadrupole mass spectrometer's sensitivity, selectivity, speed and capacity for continuous operation make the system ideally suited for evolved gas analysis in combination with thermal analyzers, specifically Thermogravimetry (TGA) and Simultaneous Thermal Analysis (STA, TGA-DTA/DSC).

Such coupling with thermal analyzers is optimized thanks to the small dimensions of the quadrupole mass filter, the efficient and reproducible ionization of gases in the electron impact ion source, and the resolution in the detection of molecules, atoms and fragments.



HYPHENATION OF THERMAL ANALYSIS AND EVOLVED GAS ANALYSIS



STA 449 **F1** Jupiter coupled to QMS 403 Aëolos Quadro; other thermal analyzers can also be coupled to MS, such as the TG 209 **F1** Libra

Ideal Gas Flow Conditions Ensure Transport of All Relevant Gases

The aim of coupling is to have all relevant gases and vapors transported from the sample area into the ion source of the mass spectrometer for precise qualitative and quantitative analysis. This is only achieved through perfect gas flow conditions in the thermal analyzer, the coupling interface and the gas inlet of the mass spectrometer. As only a small amount of gas is required for the analysis, a bypass is used at the gas outlet on the thermobalance for the excess purge gas flow; i.e., for the flow not passing through the coupling interface. This can then be used for a second gas analyzer such as FT-IR.

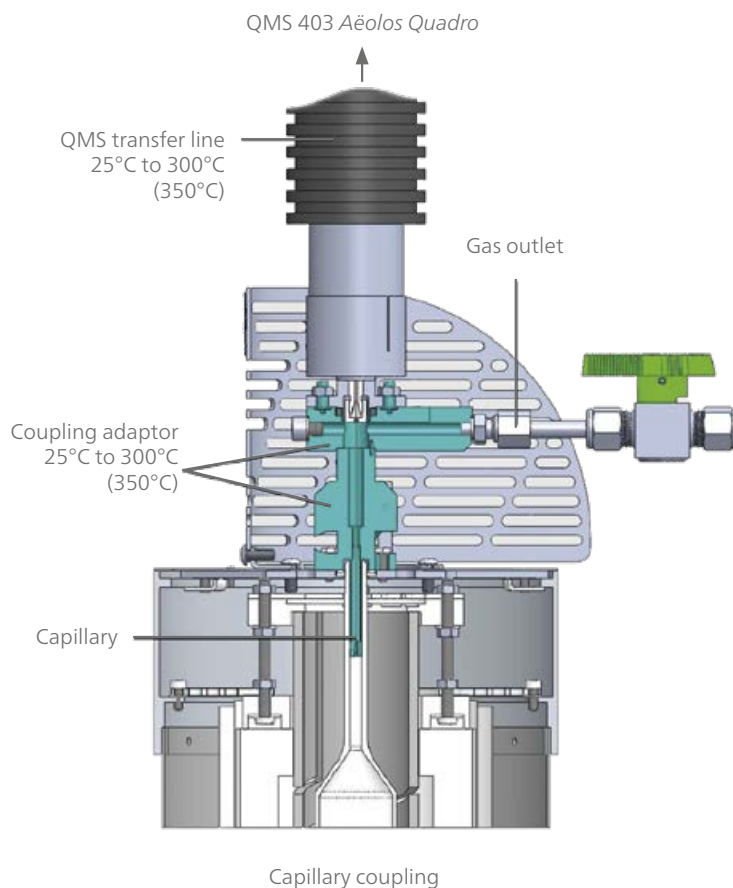

A Single-Step Pressure Reduction

Mass spectrometers, composed of a mass filter, an electron impact ion source and an ion detector, work only in high vacuum. Therefore, an interface is required for the coupling of a thermobalance – which works with a purge gas flow at atmospheric pressure – to the mass spectrometer.

A single-step pressure reduction is realized by a capillary of small internal diameter which connects the gas outlet on the furnace of the thermobalance with the gas inlet on the mass spectrometer. The pressure drops from atmospheric pressure down to high vacuum in one continuous step.

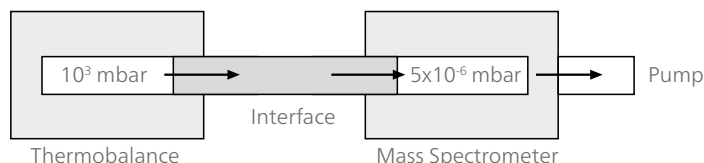

Schematic of the pressure adjustment interface provided by the capillary coupling

TA-QMS 403 *Aëolos Quadro* Coupling

Top-Notch Capillary Coupling – Heating Throughout and Single-Step Pressure Reduction

The QMS 403 *Aëolos Quadro* quadrupole mass spectrometer features a fleshed-out design for capillary coupling to NETZSCH thermal analyzers (e.g., simultaneous TGA-DSC or STA). Volatile sample materials under controlled temperature treatment are directly transferred into the electron impact ion source of the MS via a fused silica capillary (optionally capillary made of stainless steel).

The Capillary Coupling Is Designed for Optimum Gas Flow Conditions and Flexibility

- Minimization of cold spots in the transfer path
- Minimized condensation losses due to an even temperature of 300°C (optionally 350°C) throughout the entire gas transfer system from the furnace outlet to the capillary to the MS gas inlet
- Flexible, allowing standard thermoanalytical measurements and also simultaneous TGA, MS (GC-MS) and MS-FT-IR measurements
- Very robust and service-friendly while still maintaining high sensitivity (detectable mass loss in the µg-range)
- Allows TGA-MS measurements under humid atmospheres
- Allows for the upgrade of existing thermal analyzers

Hyperbolic Rod System

The hyperbolic rod system provides improved transmission and peak separation and corresponds exactly to the theoretical calculations (equations of motion) of the quadrupole.

- High transmission in high mass range
- Improved sensitivity in low mass range (H₂, He)
- Reduction of quadrupole contamination by optimized ion beam-guiding pre-filter

The QMS 403 *Aëolos Quadro* – Coupled or Stand-Alone, the Perfect QMS for Gas Detection up to 300 u (Optionally 512 u)

- High peak stability over full mass range
- Hyperbolic quadrupole system with pre-filter
- SEM with discrete dynodes and integrated Faraday cup for high dynamic range and long lifetime
- EI source with two Y₂O₃-coated filaments
- 3-D presentation of MS and thermal analysis data
- Temperature of entire transfer system (incl. adapter) 300°C/350°C
- Internal reference for mass scale adjustment over the entire mass range
- Operation and data evaluation with Proteus software
- QMS system can also be independently employed for the analysis of other gas sources



Capillary Coupling Possibilities for the QMS 403 Aëolos Quadro

TGA-DSC/DTA Systems

- STA 449 **F1** Jupiter: -150°C to 2000°C
- STA 449 **F3** Jupiter: -150°C to 2400°C
- STA 449 **F5** Jupiter: RT to 1600°C

TGA Systems

- TG 209 **F1** Libra: RT to 1100°C

Dilatometer/Thermomechanical Analyzer

- DIL 402 *Expedis Supreme**: RT to 1600°C
- DIL 402 *Expedis Select*: RT to 1600°C
- TMA 402 **F1/F3** Hyperion: -150°C to 1550°C

DSC Systems

- DSC 404 **F1/F3** Pegasus: -150°C to 2000°C

* The total temperature range depends on the furnace

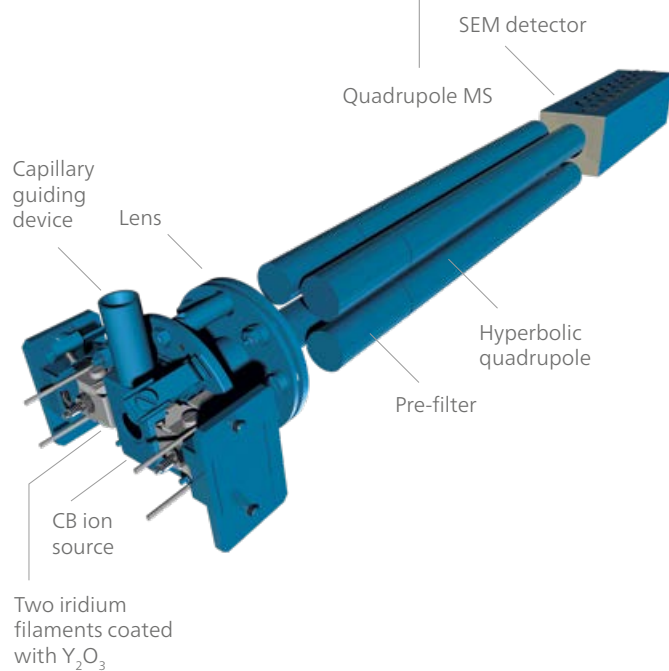

High Detection Sensitivity from Low to

Hydrogen and Xenon

Detected by the QMS 403 *Aëolos Quadro*

Detection Sensitivity for Hydrogen

For demonstration of the detection sensitivity in the low mass range, argon purge gas was treated with pulses of hydrogen by using the NETZSCH *PulseTA*. The volume of the pulses was equivalent to 1 µg, 5 µg and 10 µg hydrogen.

For m/z 2, an integration time of 1 s was used. Due to high performance of the MS, low hydrogen quantities can be detected with high precision. Excellent linearity enables quantification over a large concentration range.

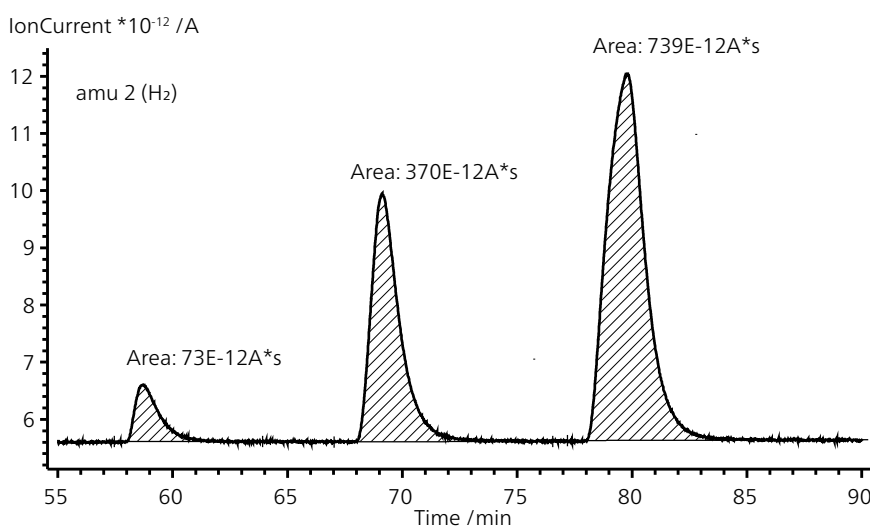

STA-MS measurement of hydrogen pulses at constant temperature

Detection Sensitivity for Xenon in Air

Xenon is a trace gas in the earth's atmosphere, occurring at approximately 1 part per 11.5 million. Naturally occurring xenon is composed of eight stable isotopes. This measurement plot clearly shows 30 ppb of xenon with the stable Xe isotopes:

- ^{129}Xe (abundance: 26.401%)
- ^{131}Xe (abundance: 21.231%)
- ^{132}Xe (abundance: 26.909%)
- ^{134}Xe (abundance: 10.436%)
- ^{136}Xe (abundance: 8.857%).

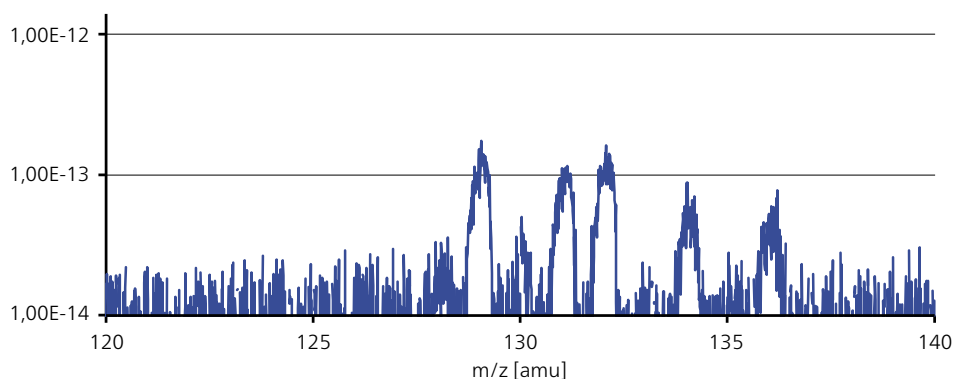

Determination of Xe in the air; SEM 950 V, scan 0 to 140 u, StW 0.01, ST 20 ms, IT 100 ms. For this measurement, the QMS 403 *Aëolos Quadro* was used as a stand-alone instrument and not coupled to a thermal analyzer.

High Mass Range

Continuous heating of the entire gas transfer line reduces the risk of condensation so that even larger molecules can be detected.

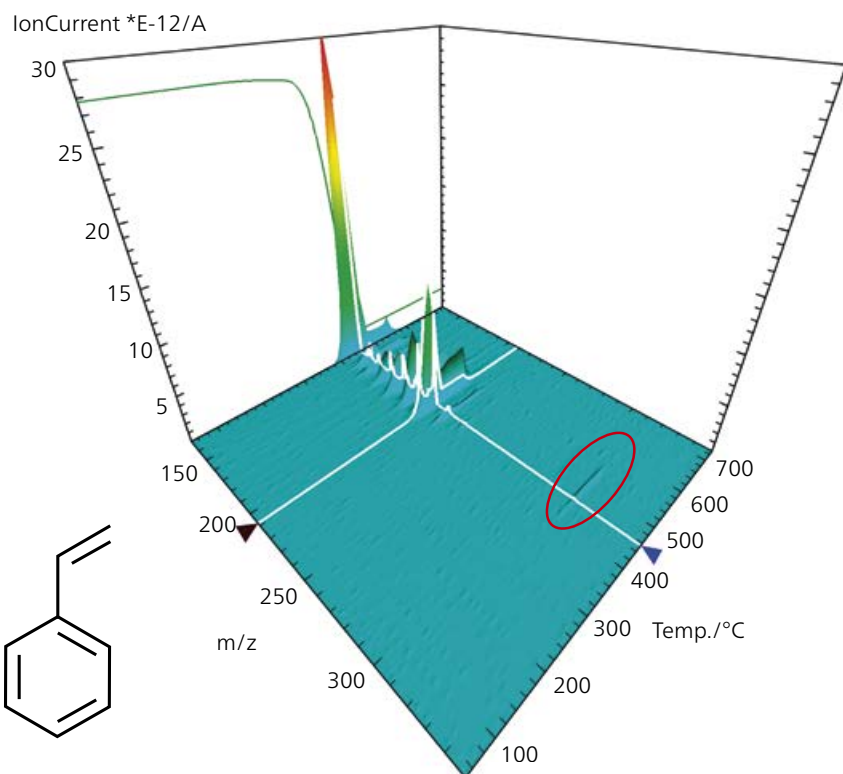

High Detection Sensitivity Even for High Mass Numbers

This TGA-QMS *Aëolos Quadro* measurement on polystyrene (PS, granulates) shows one mass-loss step between 300°C and 560°C. The plot indicates styrene (m/z 104) and its dimer detected at m/z 208.

The high detection sensitivity of the QMS *Aëolos Quadro* is substantiated with detection of the trimer at m/z 312 (see red circle).

Proteus

The Software for Performing Simultaneous Measurements Using Thermal Analysis Coupled with the QMS 403 Aëolos Quadro

Measurements using STA/TGA/DSC/DIL instruments coupled to the QMS 403 *Aëolos Quadro* can be controlled entirely via Proteus software, which combines the measurement and analysis software of the two coupled methods into a single software application for both control and data acquisition. *Proteus* allows for the individual definition of any parameters relevant to thermal analysis (e.g., temperature program, heating rate, etc.) as well as any parameters relevant to the mass spectrometer (e.g., mass ranges, scans, etc.). For hyphenated measurements, the two systems (STA/TGA/DSC/DIL and QMS 403 *Aëolos Quadro*) are started and stopped simultaneously.

During the measurement, the thermoanalytical and MS data are displayed in a common plot and stored in a measurement file. This is then used in the *Proteus* analysis software for joint presentation and evaluation. There is no longer any need for complicated data import or switching between different applications.

Comprehensive Information via Scan-Bargraph

A scan-bargraph is often the basis for depicting comprehensive information about all of a sample's evolved species; it allows for displaying a selection of all mass numbers or just individual ones of interest in *Proteus* software as continuous MID curves. Here, one of the repeated scans is shown for heptadecane measured in argon.

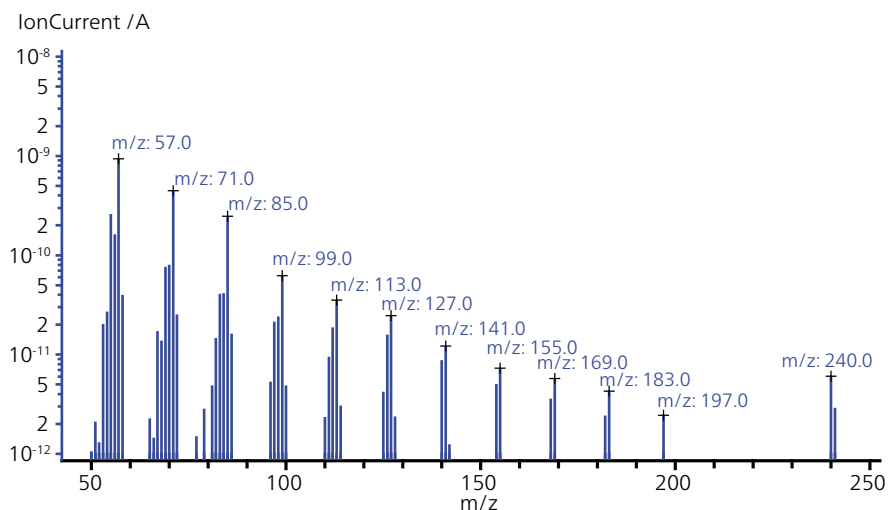

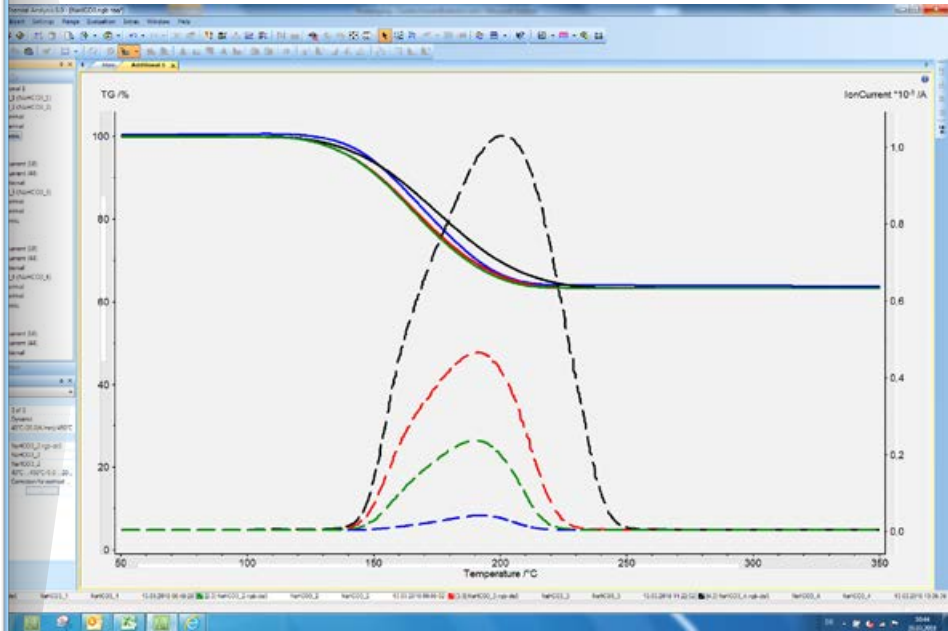
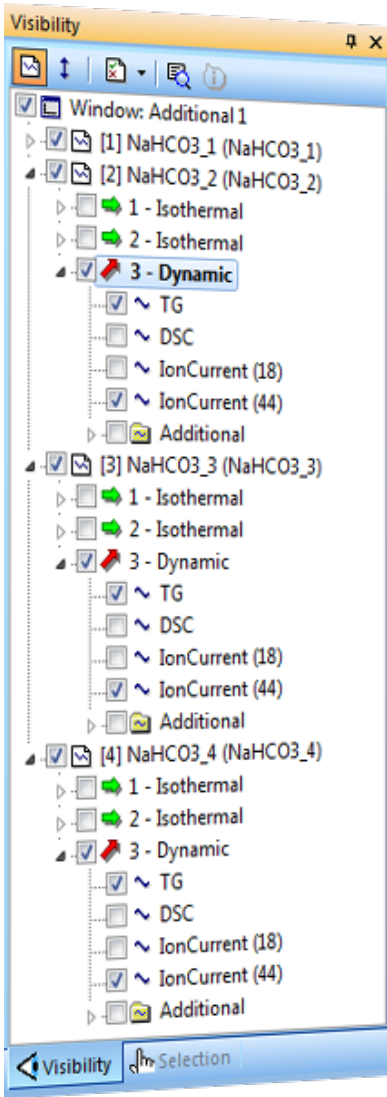

Excellent correlation between the area of the MS signal and decreasing sample mass

Direct Correlation Between Mass Loss and Evolved Gas via MID Curves

Several TGA measurements on baking soda with decreasing sample mass (plot on top, solid lines), when compared with the evolving CO_2 shown as MID curves (m/z 44, dashed lines), exhibit a linear relationship between the sample mass and CO_2 (see plot below). This behavior demonstrates the very good linearity of the *Aëolos Quadro* mass spectrometer.

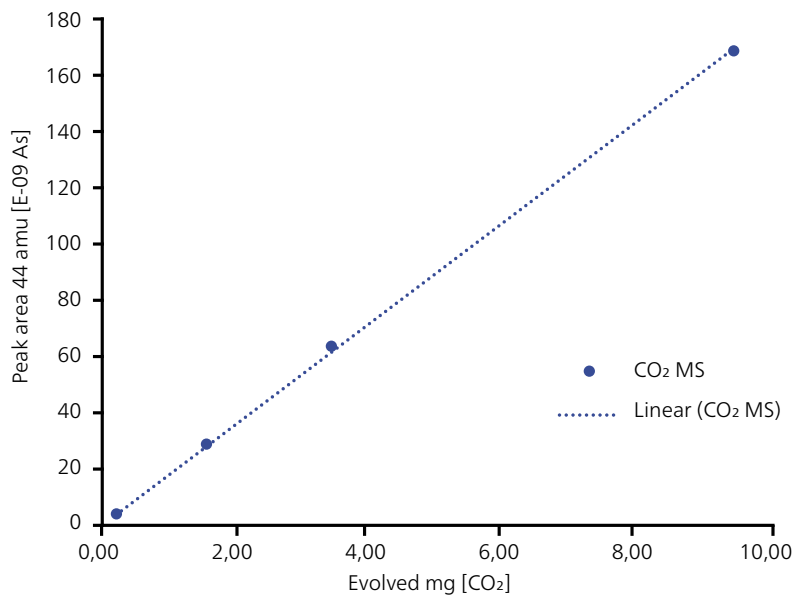

Evolution of CO_2 from baking soda (NaHCO_3)



Key Software Features

Measurement

- Complete integration of thermal analysis and QMS software into *Proteus*
- Method-based measurement and evaluation
- Simultaneous start/stop of the coupled measurements
- Three different scan modes: scan analog, scan bargraph, MID
- Selection of different scan bargraph ranges at the same time
- Selection of scan bargraph or scan analog with optimized rate and sensitivity in different channels
- Individual MS parameters for each position of the automatic sample changer

Analysis

- Evaluation of MS results within *Proteus*
- Evaluation of results precisely correlated in terms of time and temperature
- Presentation of MS signals (TIC and individual mass numbers) together with thermoanalytical curve
- 3-D presentation of spectra data together with temperature, TGA and/or DSC curves and single mass number traces, including peak determination, different color schemes, and surface views
- Easy extraction of 2-D MS data from 3-D plot for database comparison
- Spectra export in NIST format for identification in the NIST database



QMS 403 Aëolos Quadro Coupling

QMS Data

Mass range*	1 u to 300 u (optionally to 512 u); including auto-tuning using PFTBA to calibrate the mass scale axis
Mass filter	Quadrupole with hyperbolic rods and pre-filter (patented)
Ion source	Cross-beam EI ion source
Cathodes/filaments	Two iridium cathodes with Y ₂ O ₃ coating
Electron energy	25 eV to 150 eV
Emission current	0.1 mA to 2 mA
Detector	SEM with discrete dynodes and integrated Faraday cup
Dynamic range (electronic)	9 decades
Detection limit	< 100 ppb (gas-dependent)
Resolution	0.5 u to 1.5 u
Vacuum system	Turbo molecular pump with 4-stage diaphragm pump (oil-free)
RF generator	High-stability fully digital RF generator
Measuring modes	Scan analog, scan bargraph, MID
Scan rate (electronic)	> 100 u/s (scan bargraph) → possible with reduced dynamics (10 u to 100 u, fixed measurement range of 1E-7, short settling and integration time; however, sufficient sensitivity for library search)
Use as stand-alone instrument	Yes
Power	115 - 230 VAC / 50 - 60 Hz
Power consumption	≈ 800 W

Transfer System from the Thermal Analyzer to MS

Adapter systems (STA/TGA/DSC/DIL to capillary and capillary to MS gas inlet system)	<ul style="list-style-type: none"> ■ Heated adapter and transfer line ■ Temperature adjustable to T_{max} 300°C (optionally T_{max} 350°C) ■ Single-step pressure reduction, no orifice
Entirely insulated capillary	<ul style="list-style-type: none"> ■ Made of quartz glass, max. 300°C, length ≈ 3 m, Ø 60 µm (Optionally made entirely of insulated stainless steel, max. 350°C, length » 2.5 m) ■ Spare loop inside a furnace above the MS casing ■ Can be changed out by the customer
Vacuum-tight connection between thermal analyzer and MS	Yes
Pressure reduction from thermal analyzer to MS	Single-step pressure reduction from 10 ³ mbar to 5x10 ⁻⁶ mbar

Technical Specifications

PulseTA

Calibration/Quantification

The quantification of MS signals requires calibration of the whole coupled system with a known type and amount of gas or solvent to control for the temperature-dependent flow properties. *PulseTA* is a perfect tool for achieving quantitative gas detection in separate calibration runs or even online during a sample measurement. A known amount of gas is injected into the sample gas stream and the registered signal of the resulting pulse is integrated. The application of *PulseTA* also allows for studying gas/solid reactions with stepwise control of the process via the injection of a reactive gas, and simplifies adsorption/desorption experiments and studies of catalytic reactions. The valve is completely controlled by the NETSZCH *Proteus* software. It is no longer necessary to define the gas injection manually.

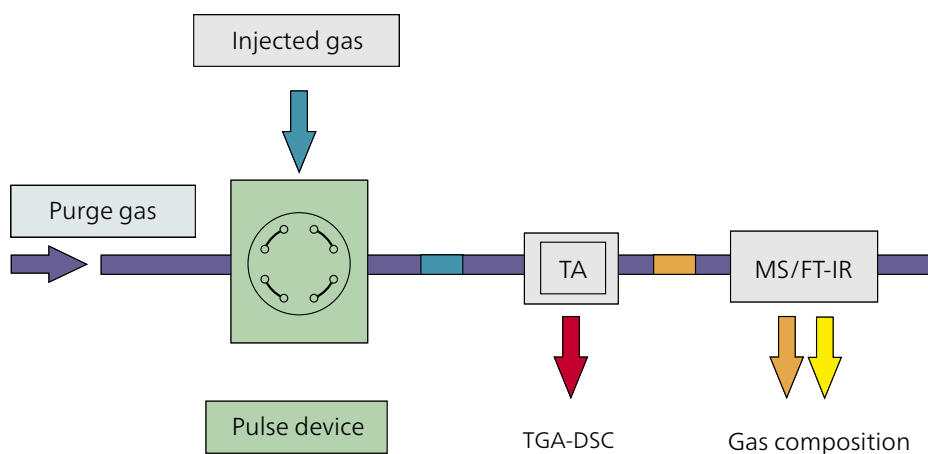

Inert gas

CO₂ pulses for calibration of a carbonate decomposition

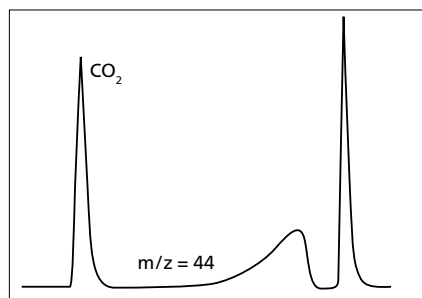

Reactive gas (gas-solid reaction)

Reduction of metal oxide by H₂ pulses

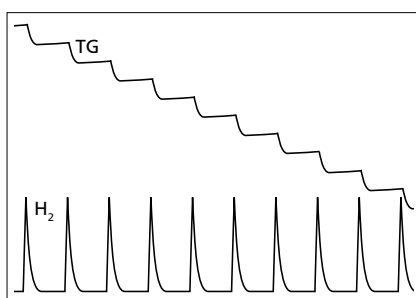

Reactive gas (adsorption)

NH₃ adsorption by a zeolite sample

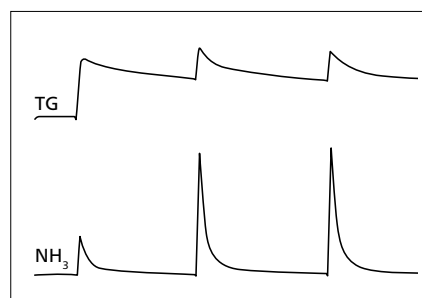



Solid-Gas Reaction of Burned Lime with Carbon Dioxide

In this example, calcium oxide (CaO, burned lime) was treated with defined injections of CO₂ at 43°C. The volume of each injected pulse amounted to 250 µl.

Each gas injection causes a reaction of solid CaO with the reactive CO₂ gas, which can be seen via the stepwise increase in the sample mass. With each consecutive gas uptake, however, the height of the new step reduces.

This reaction may be continued until a plateau in the TGA signal is reached. Simultaneously, the peak area below the MS signal for m/z 44 (referring to CO₂) can be evaluated. The peak area increases as the amount of CaO conversion decreases. The higher the level of saturation with CO₂, the lower the consumption of the pulse gas.

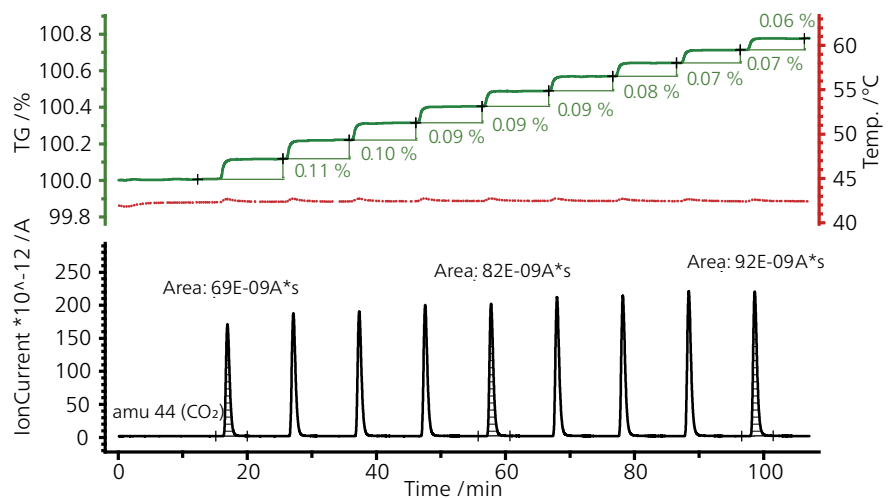

Isothermal treatment of CaO (177.8 mg) on a Pt grid sample carrier at 43°C in a dry argon atmosphere with pulses of 250 µl of CO₂



The NETZSCH Group is a mid-sized, family-owned German company engaging in the manufacture of machinery and instrumentation with worldwide production, sales, and service branches.

The three Business Units – Analyzing & Testing, Grinding & Dispersing and Pumps & Systems – provide tailored solutions for highest-level needs. Over 3,500 employees at 210 sales and production centers in 35 countries across the globe guarantee that expert service is never far from our customers.

When it comes to Thermal Analysis, Calorimetry (adiabatic & reaction) and the determination of Thermophysical Properties, NETZSCH has it covered. Our 50 years of applications experience, broad state-of-the-art product line and comprehensive service offerings ensure that our solutions will not only meet your every requirement but also exceed your every expectation.

Proven Excellence. ■

NETZSCH-Gerätebau GmbH
Wittelsbacherstraße 42
95100 Selb
Germany
Tel.: +49 9287 881-0
Fax: +49 9287 881 505
at@netzsch.com

NETZSCH®

www.netzsch.com