

NETZSCH



Differential Scanning Calorimetry – DSC 3500 *Sirius*®

Method, Technique and Applications

Leading Thermal Analysis ■

Differential Scanning

Differential Scanning Calorimetry (DSC) is one of the most frequently employed thermal analysis methods. It can be used to analyze nearly any energetic effect occurring in a solid or liquid during thermal treatment.

Easy handling and rapid analysis are among the hallmarks of this analytical technique, which has proven to be highly significant in the areas of research, development, and quality control. There are a variety of standards (ASTM, DIN, ISO, etc.) for the application, evaluation and interpretation of specific materials, products and properties.



DSC Measurement Information

- Specific heat determination (c_p)
- Glass transition temperatures
- Melting/crystallization behavior
- Degree of crystallinity
- Cross-linking reactions
- Compatibility
- Oxidative stability
- Solid-solid transitions
- Decomposition onset
- Polymorphism
- Phase transitions
- Liquid crystal transitions
- Eutectic purity
- Cross-linking reactions
- Specific heat
- Purity Determination
- Thermokinetics

Calorimetry

THE DSC METHOD

The DSC 3500 *Sirius*® operates according to the heat-flux principle. With this method, a sample and a reference are subjected to a controlled temperature program (heating, cooling or isothermal). The actual measured properties are the temperature of the sample and the temperature difference between sample and reference. From the raw data signals, the heat flow difference between sample and reference can be determined which represents the caloric changes of the sample.

The sample is placed inside a crucible which is then placed inside the measurement cell (furnace) of the DSC system along with a reference pan which is normally empty.

The DSC 3500 *Sirius*® is in line with nearly every respective instrument and application standard, including: ISO 11357, ASTM E793, ASTM D3895, ASTM D3418, DIN 51004, DIN 51007, DIN 53765.

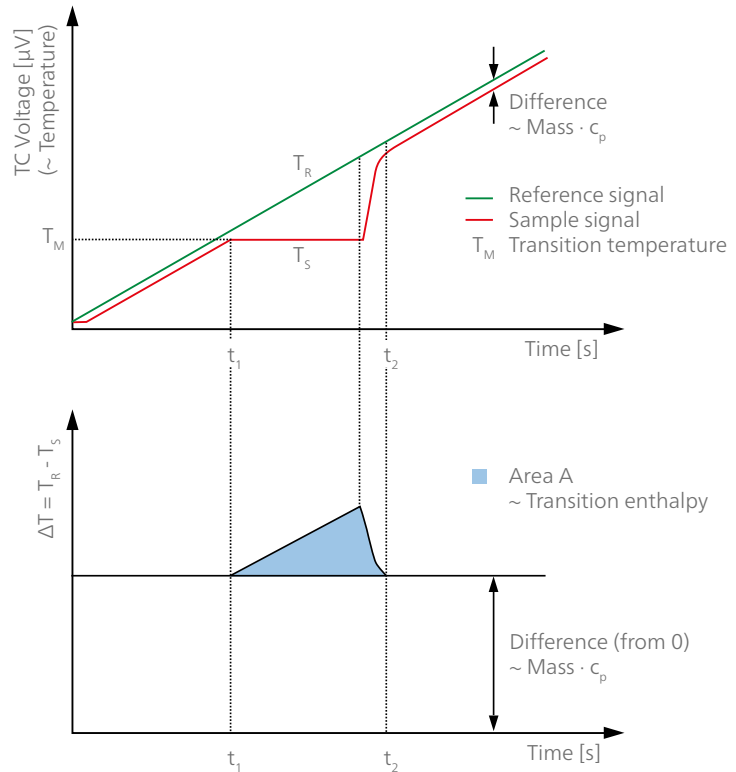

Signal generation in a heat-flux DSC

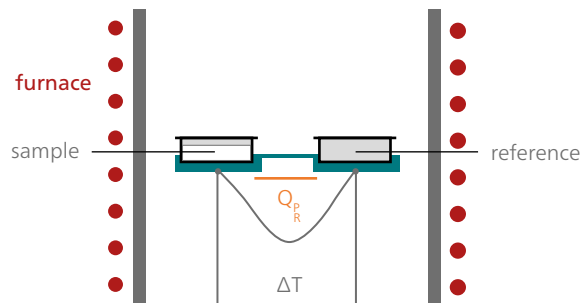

Schematic of a heat-flux DSC cell

DSC 3500 *Sirius*®

The gas-tight DSC 3500 *Sirius*® combines the advantages of modern technology, high sensitivity and a robust, easy-to-operate workhorse. Tests can be carried out in the temperature range between -170°C and 600°C.

Key components of the DSC 3500 *Sirius*® are the DSC heat-flux sensor, the furnace and clever connection fittings which are designed for the quick and easy attachment of various cooling systems.

The sensor of the DSC 3500 *Sirius*® combines high stability and optimized resolution of thermal effects. Laser-guided welding processes for the sensor disks and thermocouple wires yield true sensitivity and robustness.

*TRUSTWORTHY
AND STURDY*



ADVANTAGES TO YOUR BENEFIT

Reliable

Furnace and Sensor

Optimized design of the furnace and the sensor results in a highly stable baseline and excellent signal-to-noise ratio.

Variable

Gases and Cooling Options

Protective and purge gas inlets are, of course, standard features of the unit. For improved cooling times and subambient temperature tests, various cooling options can be connected. Of course, a versatile gas switching and flow control system are also available.

Efficient

Automatic Sample Changer

For applications with a high sample throughput, we offer an automatic sample changer (ASC) for up to 20 samples and references which accommodates different crucible types. Flexibility and high sample throughput allow for efficient time management.

All-Encompassing

Smart Instrumentation

Ease of handling is provided during measurement setup and evaluation by the *SmartMode*. This incorporates predefined measurement methods and wizards, *Auto-Evaluation* and *Identify*.

RELIABLE INSTRUMENTATION

From Measurement Setup to

SmartMode – There's no need to be an expert in thermal analysis to start a measurement!

Just a few clicks
to start a
measurement

SmartMode – No Need to be Well Versed

The *SmartMode* boasts a clear structure, a consistent navigation concept and easy-to-access buttons. Using Wizards (measurement templates), it is possible to start a measurement with just a few inputs. Alternatively, customized methods or predefined methods can be selected to set up an experiment. The predefined methods already contain all required parameters for those materials which are listed in the NETZSCH poster "Thermal Properties of Polymers".

Even customers unfamiliar with the software immediately know how to proceed.

ExpertMode – Not Just for Professional Users

For those who wish to dive deeper into the software for enhanced option setting or for method definition, switching from *SmartMode* over to *ExpertMode* is the answer. Here, the user has access to the established *Proteus*® software functionality, including dozens of features and all adjustment settings.

AutoCalibration Allows for Full Concentration on the Measurement Tasks

Calibration procedures should be simple, fast and – ideally – done along the way. *AutoCalibration* provides automatic creation routines for all relevant calibration curves, automatically loading the current calibrations while taking the selected measurement conditions into account and checking their validity periods.





AutoEvaluation to Identify

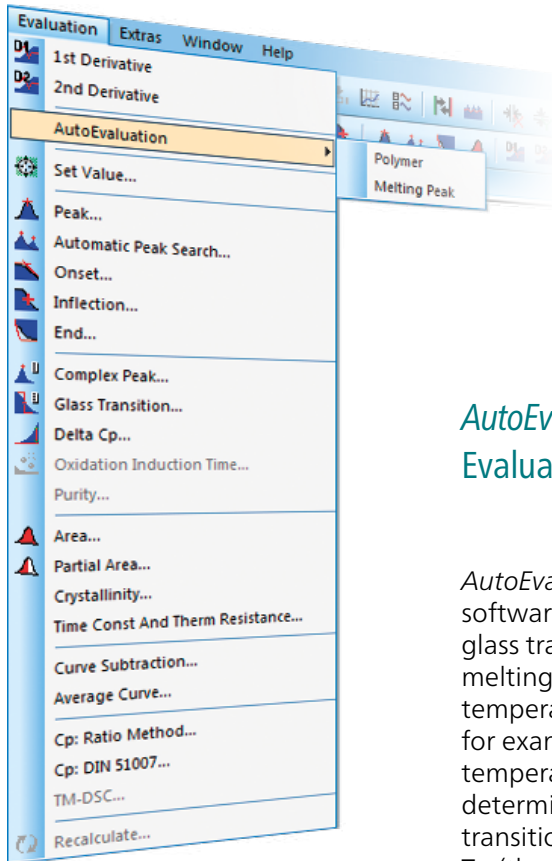

AutoEvaluation automatically analyzes unknown curves of polymers and metal melts.

*AutoEvaluation** – Autonomous Evaluation for Polymers

AutoEvaluation is a self-acting software package which evaluates glass transition temperatures, melting enthalpies or peak temperatures. For melting effects, for example, both the peak temperature and the enthalpy are determined; in the case of a glass transition, the software calculates T_g (the glass transition temperature) and the step height, expressed as Δc_p .

For all those who haven't seen such measurements yet, *Auto-Evaluation* will handle the curve independently – without any effort on the operator's part. This ground-breaking technology allows, for the first time in history, test analyses which are fully user-independent and therefore completely objective.

Of course, users can still run manual evaluation, if required.

*Identify** – A Step Ahead with the Database

The *Identify* software searches for similar results stored in polymer libraries, providing instantaneous interpretation of the measurement at hand.

With the *Identify* software package, it is possible to carry out one-on-one comparisons with individual curves or literature data from selected libraries, or to check whether a particular curve belongs to a certain class. These classes may contain sets of data for various types of the same polymer – e.g., several types of PE – but also curves, such as ones which are classified as PASS or FAIL in terms of quality control.

Both the libraries and the classes are boundless and users can expand them with experiments and knowledge of their own.

* Optional software extensions

Stable Baselines & High Repeatability

Smart Furnace – Sensor Design

The heating wires of the furnace surround the entire sensor plate. They are arranged in such a way that no temperature gradients occur in or above the sensor disk. This arrangement is the basis for a highly homogeneous heat flow to the sample and reference pans from all sides and therefore also for a very stable baseline and an optimum signal-to-noise ratio.

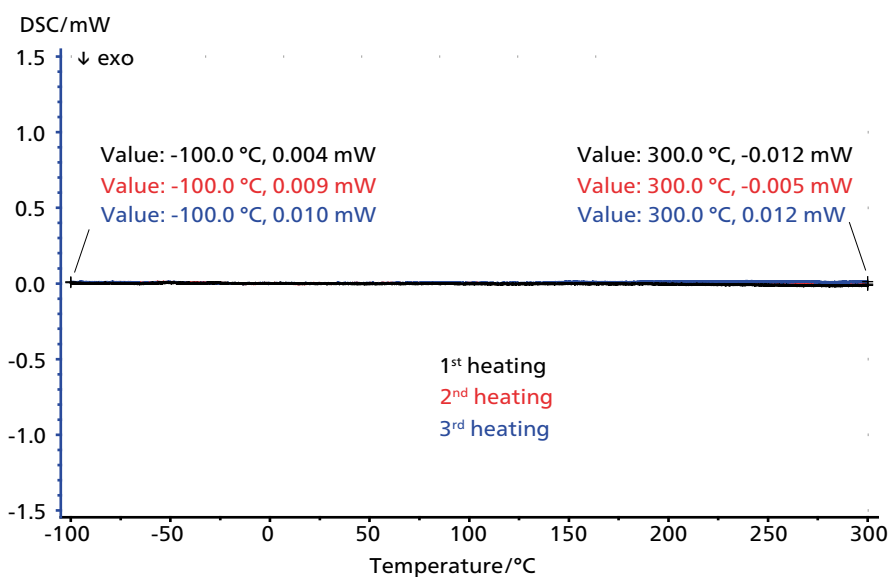

High baseline repeatability demonstrated on three measurement curves

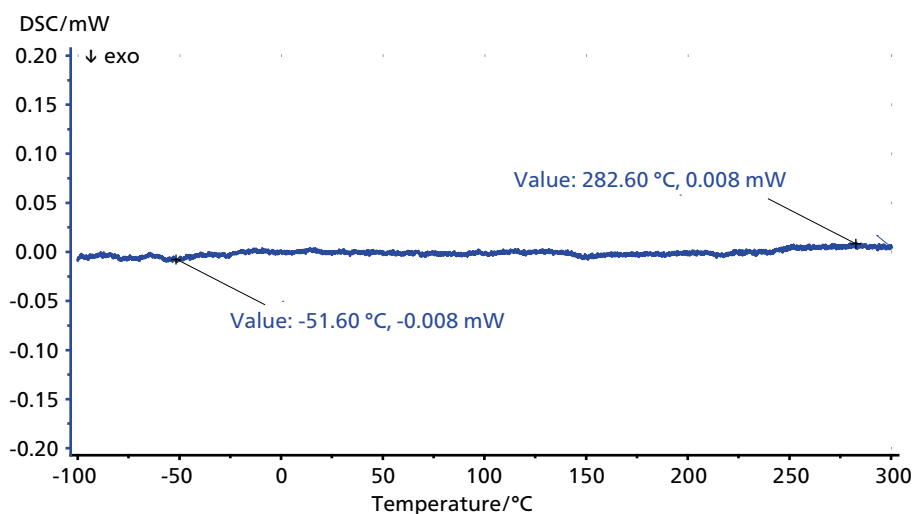
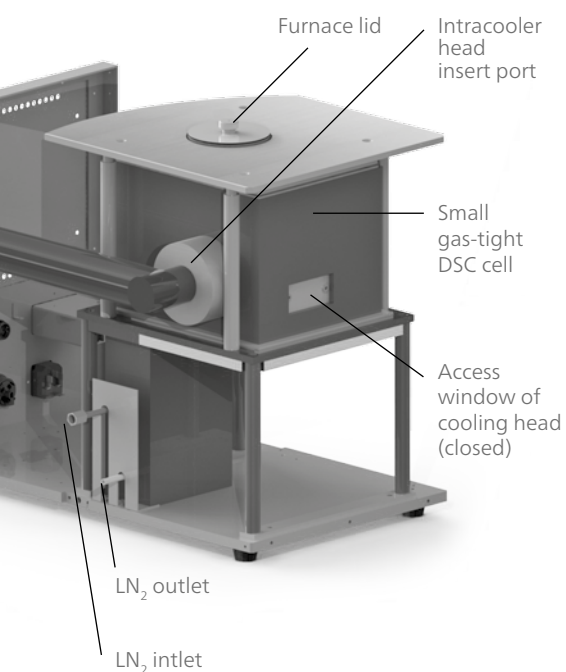

Enlarged baseline between -100°C and 300°C demonstrating that the excellent baseline stability is within the ±0.01-mW range.

Compact Design – Fits into Any Corner of Your Lab

The DSC 3500 *Sirius*® features a particularly slim design requiring only a small footprint. A clever solution for sample handling is provided by the metallic shelf on top of the DSC system.



Dimensions of the DSC 3500 *Sirius*® with optional Automatic Sample Changer (ASC)

Gas-Tight – A Prerequisite for OIT Tests

The gas-tight measurement cell offers defined atmospheres for optimum measurement conditions. Three magnetic valves control the gas flows and are on/off programmable. Alternatively, mass flow controllers are optionally available. These features all positively affect the process of determining the oxidative-induction time/temperature (OIT).

In addition, gas-tightness allows for the avoidance of any impact on the DSC system caused by high environmental humidity. Condensation problems in geographical areas with high humidity, for example, are greatly reduced.

Economic Cooling – User-Interchangeable Devices

Protective and purge gas inlets are standard features of the unit. Of course, a versatile gas switching system and flow control system are also available.

For improved cooling times and subambient temperature tests, various cooling options are available. Intracooler and liquid nitrogen (LN₂) systems can be interchanged with almost no effort by the user. Our optimized LN₂ cooling system features low liquid nitrogen consumption.

Cooling Options

- Air compressor cooling: RT to 600°C
- Vortex cooling: 0°C to 600°C
- Intracooler IC 40: -40°C to 600°C
- Intracooler IC 70: -70°C to 600°C
- Liquid nitrogen: -170°C to 600°C
- Al cooling body

Small but Powerful



Automatic Sample Changer

SUPERVISION RELINQUISHED

For applications with high sample throughput, an automatic sample changer (ASC) for up to 20 samples and references is available. Besides standard aluminum pans, the ASC can accommodate pressure-tight crucibles (autoclaves), ceramic and metallic sample pans.

Transport safety is provided by the four arms of the gripper. This mechanism safely removes the crucible from the magazine and places it carefully – without jiggling – into its position on the sensor. The reference crucible can also be changed out as often as the application requires.

The ASC can be easily programmed via the *SmartMode* of the *Proteus*® software. A specific measurement program (method) can be assigned to each sample on the tray. This can include evaluation routines as well. In other words, the ASC not only handles the samples, but also carries out measurement and evaluation without the need for supervision.

Light-Curing via UV Add-On



Besides thermally activated reactions, which can be studied by conventional Differential Scanning Calorimetry (DSC), many polyaddition reactions and radical polymerizations can also be started by irradiation with sufficiently high energy.

For the DSC 3500 *Sirius*®, we offer a UV add-on consisting of a UV lamp and controller, a pulse generator for shutter control, and a UV fiber lid with a lid rest for convenient handling.

Advantages of Photo-DSC Tests

- Extending the DSC technique with light radiation capability
- Analyzing photo-initiated reactions in a broad variety of materials
- Measuring the light curing of polymer resins, paints, coatings and adhesives (degree of cross-linking)
- Studying the influence of UV stabilizers in pharmaceuticals, cosmetics and foods (aging effects)
- Selecting temperature, atmosphere, light intensity, wavelength and exposure time
- Determining the reactivity and curing time of dental composites



Technical Specifications of the UV Add-On

Temperature range	-100°C to 200°C	
Crucibles	Open aluminum	
Recommended Hg-lamp types	DELOUX 04	Omniculture® S 2000
Max. power	9.9 W/cm ²	> 10 W/cm ²
Wavelength range	315 nm to 500 nm	320 nm to 500 nm
Irradiation time	0.1 s to 1000 s	0.2 s to 1000 s
Existing orifice diameter	8 mm, 4 mm, 2 mm	8 mm, 4 mm, 2 mm



Identification

The DSC 3500 Sirius® is also well suited for investigations in the polymer and food industries.

Packaging Films Based on PE, PP and PA

The upper plot displays the 2nd heating runs for three different packaging films A, B and C. Only for samples A and B was a later peak detected – at 247°C and 253°C, respectively – which is the typical melting range for different kinds of polyamides (PA). The peak at 159°C exhibited solely by film C is most probably attributable to the melting of polypropylene (PP).

The two peaks additionally located at 126°C and 140°C, as well as those detected in the same temperature range in the DSC curves of films A and B, are due to the different polyethylene (PE) types.

In the figure below, the advanced *Peak Separation* software was used to separate the three peaks detected in sample B between 100°C and 125°C. The graph shows the almost perfect correlation between the measured curve (dotted) and the sum of three calculated curves (red).

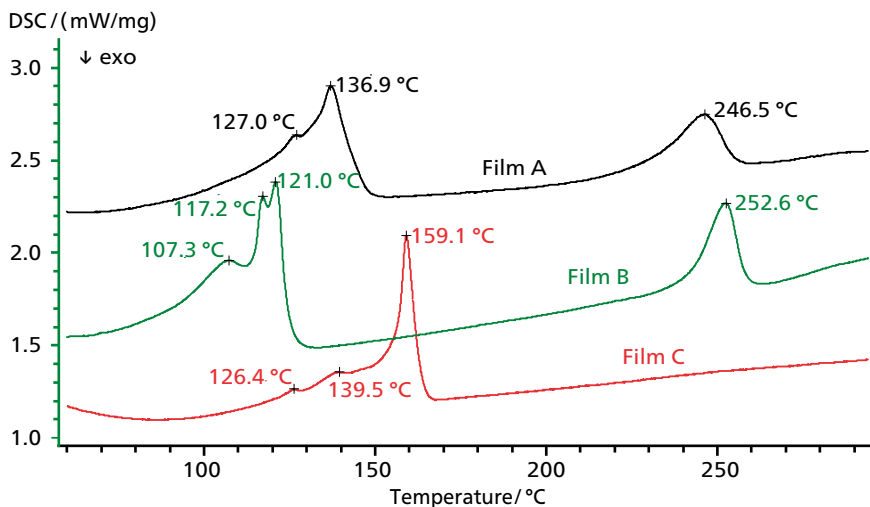

2nd heating runs on three materials between 30°C and 300°C; heating rate of 10 K/min. The 1st heating yields information on the thermal history of a polymer; the 2nd heating reflects its material properties.

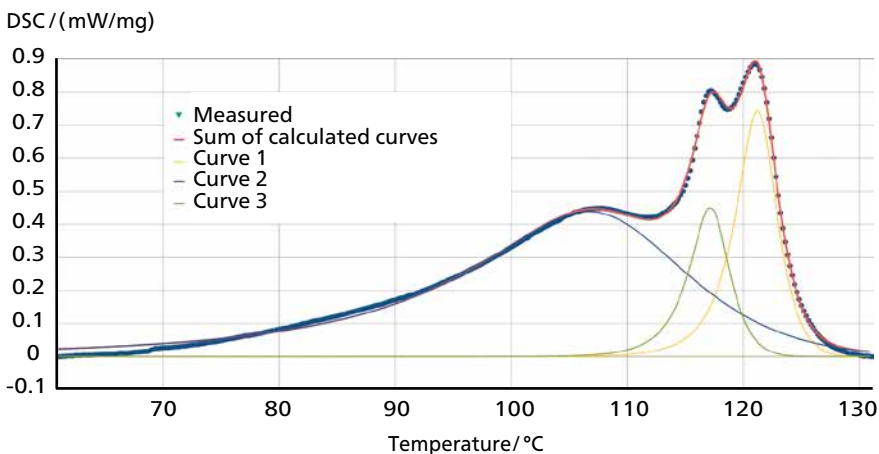

Separation of the triple peak of sample B by means of the optional software package *Peak Separation*

Composition and Oxidative Stability

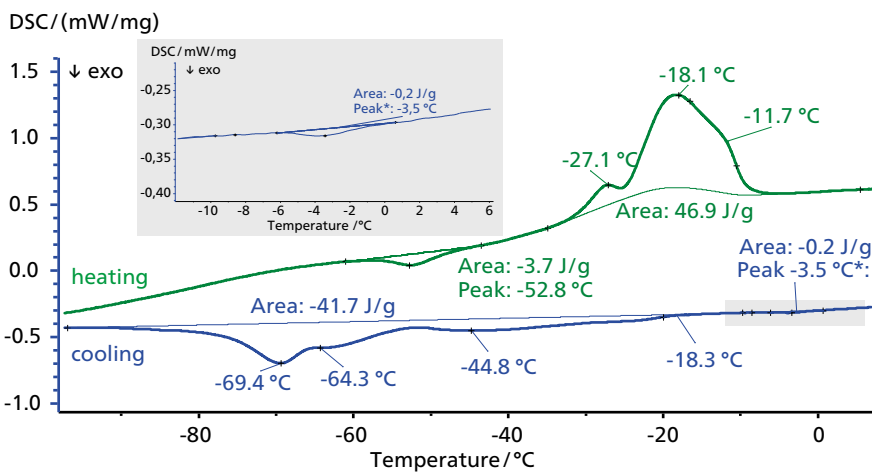

Rapeseed oil, sample mass: 1.19 mg, aluminum crucible with pierced lid; cooling to -150°C, heating to 40°C, heating/cooling rate 10 K/min

Melting and Crystallization Behavior of Edible Oil

This rapeseed oil sample was first cooled to -150°C and then heated to 40°C. The exothermic peak beginning at -18°C (during controlled cooling, blue curve) is due to the crystallization of the oil. The minima at -45°C, -64°C and -69°C reflect the composition of the oil consisting mainly of oleic acid, linoleic acid and linolenic acid as well as of various saturated and unsaturated fatty acids. The peak detected at -4°C is probably caused by the crystallization of an additive. In the subsequent heating, post-crystallization occurs at -53°C, followed by the melting of the oil components (peaks at 27°C, -18°C and -12°C).

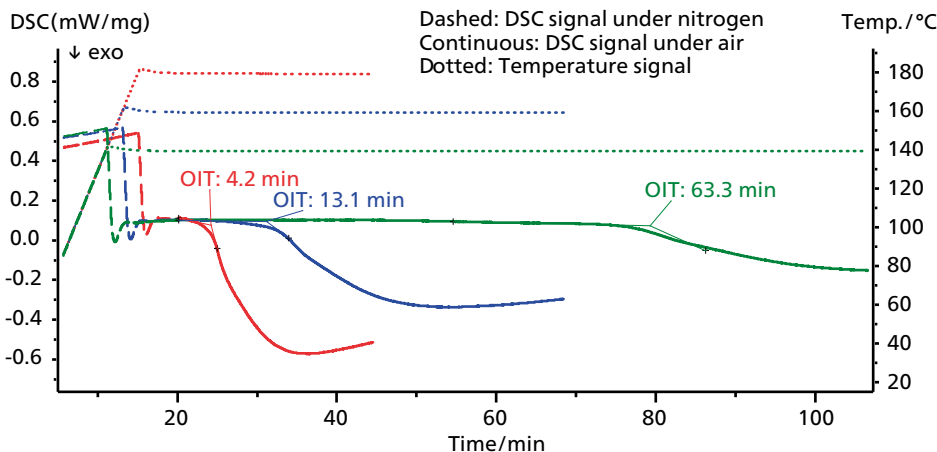

Rapeseed oil, sample mass 1.19 mg, aluminum crucible with pierced lid; cooling to -150°C, heating to 40°C, heating/cooling rate 10 K/min, isothermal temperatures 140°C (green), 160°C (blue) and 180°C (red).

Oxidative-Induction Time (OIT) – The Relative Stability of Hydrocarbons to Oxidation

This plot shows OIT measurements on rapeseed oil heated to three different temperatures under inert conditions. After a five-minute equilibration time, the atmosphere was switched to air. The DSC curves show the influence of the test temperature on the degradation of the samples. Degradation began earlier at higher temperatures: It took 63 min under oxidizing conditions at 140°C, but only 4 min for the test carried out at 180°C.

Quality Control & Failure Analysis

Quality Control on Two Solders

Two solders made of the same material but taken from different lots were each heated two times. The upper plot compares the 1st and 2nd heating segments for the two samples. Both segments exhibit an endothermic peak (onset temperature at 217°C) which is due to the melting of the metal alloys. The two alloys exhibit similar melting behavior. This is expressed not only in the shape of the curves but also in the peak temperatures and areas.

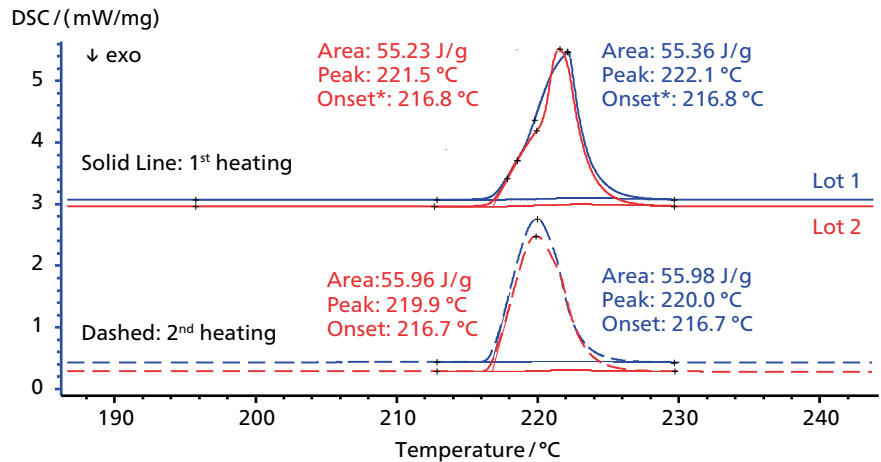

1st and 2nd heating runs on two solder materials. Sample mass 6.47 mg (lot 1)/ 7.05 mg (lot 2), Al crucible with pierced lid, heating rate 10 K/min.

The Importance of Cooling Runs

In contrast, the cooling behavior of the two samples differs after the 1st heating (lower plot). Lot 1 (blue curve) already crystallizes at 189°C, whereas lot 2 exhibits an even stronger undercooling effect; the start of crystallization is shifted to a lower temperature (endset 187°C). This effect can be explained by differing impurity content between the two products.

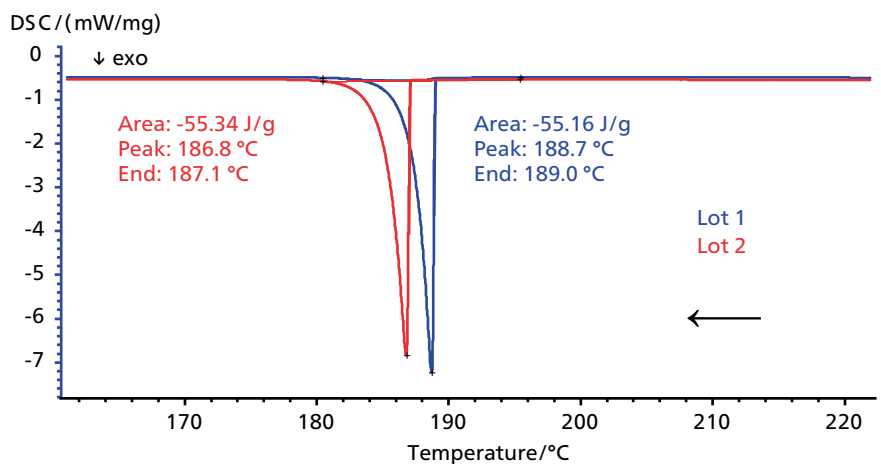

Cooling segment on the two solder materials after first heating; cooling rates of 10 K/min.

A smart metal needs
a smart instrument



*High performance for fast quality control
not only on polymers but also metals.*

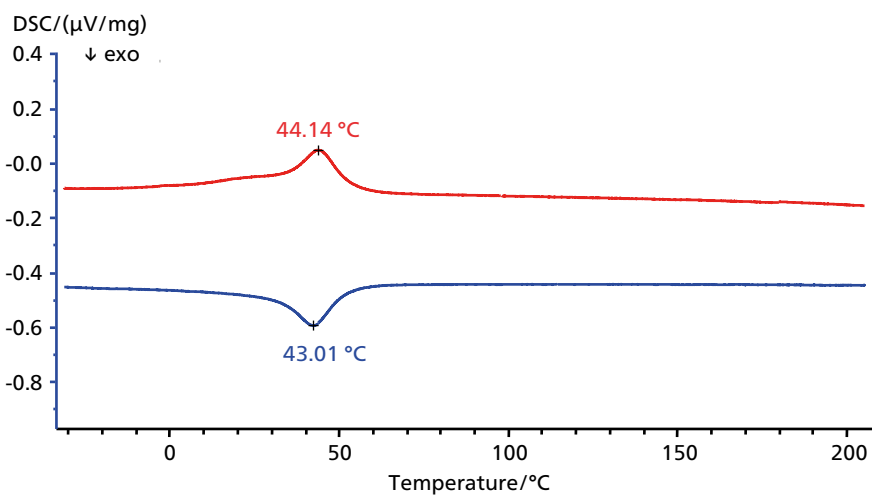

Heating (red curve) and cooling (blue curve) of a shape-memory alloy; sample mass of 13.82 mg, heating rate of 5 K/min, nitrogen atmosphere, aluminum crucible with pierced lid.

Shape-Memory Alloy

Shape-memory alloys 'remember' their original shape and, following deformation, return to their prior shape upon heating. Their most commonly encountered phase change is the martensitic transformation, which is a nondiffusional transformation. This effect can be studied by DSC. The measurement shown here on a TiNi alloy depicts the martensitic transformation of austenite at 44°C (peak temperature) during heating. During cooling, the low-temperature martensite is formed at 43°C.

Temperature-Modulated DSC

Separation of Overlapping Effects

For temperature-modulated DSC (TM-DSC), the heating rate is varied by overlapping the underlying linear heating rate with a sinusoidal temperature modulation. At the same time, the sample is subjected to a non-linear temperature (see upper plot inset). This allows for good separation of glass transitions from effects such as relaxation, curing, etc.

PVB – Determination of the Glass Transition Temperature

This TM-DSC measurement on PVB allows for the separation of the modulated signal (upper plot) into a reversing (lower plot, red curve) and non-reversing (lower plot, blue curve) signal. The glass transition is a reversible energetic effect and can be clearly seen from the reversing curve (red) at 73.5°C. The relaxation peak (at 73.8°C in the total signal, black curve) can be clearly detected in the non-reversing curve (blue, lower plot). The endothermic effect between 20°C and 60°C is due to the evaporation of humidity.

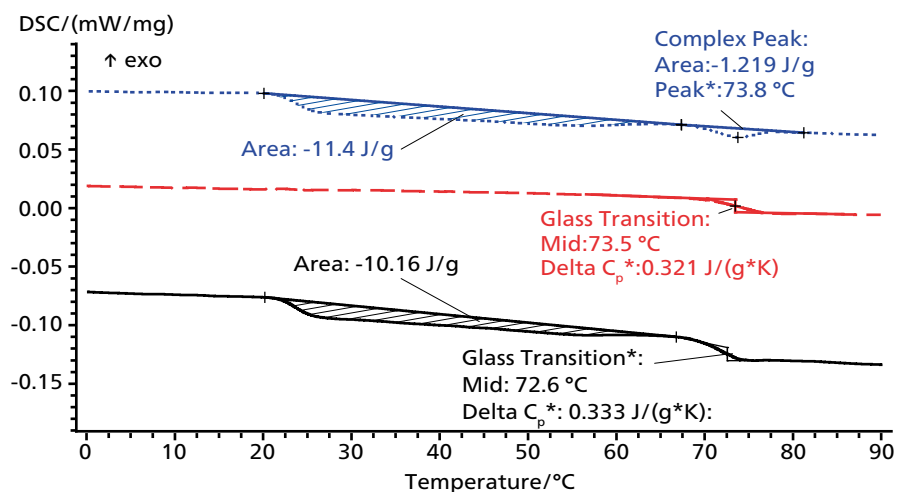
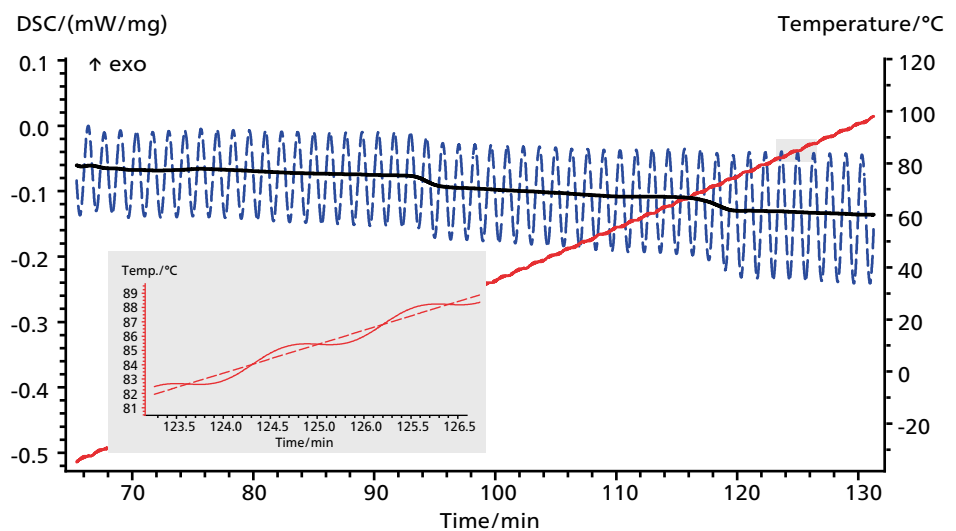

TM-DSC measurement on polyvinyl butyral film (PVB); sample mass of 6.034 mg, Al crucible with pierced lid, heating rate of 2 K/min, amplitude of 0.5°, period of 80 s, N₂ atmosphere. The sample was held under humidity for 4 h prior to the measurement.

Thermophysical Properties (TPP)

Specific Heat Capacity

Molybdenum SRM 781

The NIST standard material reference material no. 781 (99.95 mass% polycrystalline molybdenum) is a common reference material for specific heat capacity (c_p) measurements with wellproven c_p data.

For the upper plot, the DSC 3500 *Sirius*® was used to determine the c_p of SRM 781 between room temperature and 500°C.

Afterward, the heat capacity values obtained were compared with those provided by NIST (National Institute of Standards and Technology; see table below).

These measurements were performed in Pt crucibles with an alumina inlet and pierced lid (see photo).

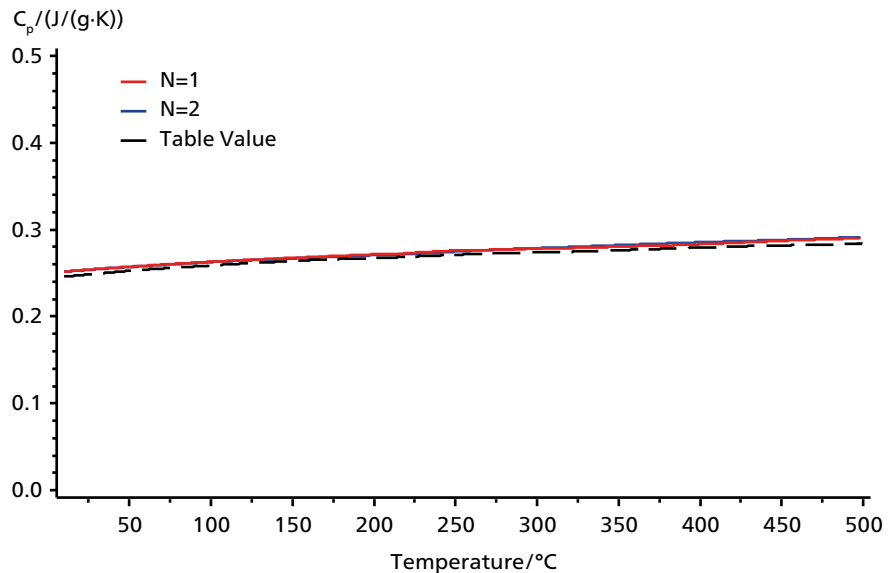

Determination of the specific heat capacity of molybdenum; sample mass 284.67mg; heating rate 10 K/min, 20 ml/min N₂ atmosphere



Experimental data in comparison with literature data (NIST) on molybdenum SRM 781

Temperature [°C]	Experimental [J/(g·K)]	C _p according to NIST [J/(g·K)]
25	0.245	0.248
100	0.263	0.259
200	0.271	0.268
300	0.278	0.274
400	0.284	0.280
500	0.291	0.285



Curing Behavior – UV Influence

Influence of Irradiation Time on a UV-Curing System

DPHA polymerizes when exposed to sources of free radicals. It is particularly useful in coatings and inks. Here, the influence of the irradiation time (1s, 10s, 30s and 60s) is demonstrated at a sample temperature of 27°C. With increasing irradiation time, the curing increased, which can be seen in the total enthalpy. The corresponding integral curves reflect the conversion due to UV curing.

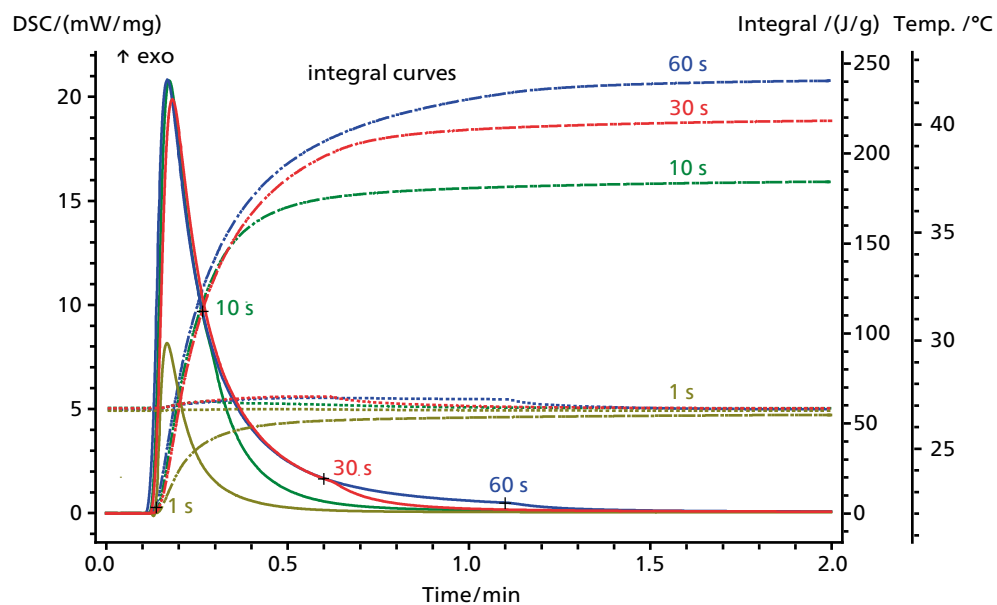

Irradiation time dependence of DPHA (dipentaerythritol penta/hexa acrylate) + irg 184 (initiator 0.05%).

The advantage of UV-curing systems is their fast reaction – within a few seconds at low isothermal temperature in the absence of solvents.

Key Technical Data

DSC 3500 Sirius®

DSC type	Gas-tight heat flux system
Temperature range	-170°C to 600°C
Heating/cooling rates	0.001 K/min to 100 K/min (cooling rate depends on temperature)
Measurement range	± 600 mW
Accuracy	<ul style="list-style-type: none"> ■ Temperature: 0.1 K ■ Enthalpy: < 1% for metals; < 2% for most materials
Cooling devices (options)	<ul style="list-style-type: none"> ■ Air compressor cooling: RT to 600°C ■ Vortex cooling: 0°C to 600°C ■ Intracooler IC 40: -40°C to 600°C; Intracooler IC 70: -70°C to 600°C ■ Liquid nitrogen cooling: -170°C to 600°C ■ Al cooling body
Atmospheres	Oxidizing, inert (static, dynamic)
Gas control	<ul style="list-style-type: none"> ■ 3 integrated frits; 3 magnetic valves (on/off programmable) ■ Optional 3 mass flow controllers or gas flow control device
Oxidative-Induction Time	Integrated in the software
Automatic sample changer (ASC)	<ul style="list-style-type: none"> ■ For up to 20 samples and references (optional) ■ Removable magazine
Software add-ons (optional)	<ul style="list-style-type: none"> ■ Temperature-modulated DSC ■ Specific heat capacity (c_p) determination ■ <i>Peak Separation</i> ■ <i>Thermokinetics</i> ■ <i>AutoEvaluation</i> ■ <i>Identify</i>
Accessories	<ul style="list-style-type: none"> ■ Variety of crucibles (Al, Pt, Al₂O₃, Au, Ag, Cu, autoclaves, etc.) ■ For easy sample preparation, <i>SampleCutter</i> and sample preparation kit
Dimensions of instrument	<ul style="list-style-type: none"> ■ Height 380 mm (560 mm with ASC) x width 320 mm x depth 520 mm ■ Mass: 28 kg



Sealing press for different aluminum crucible types

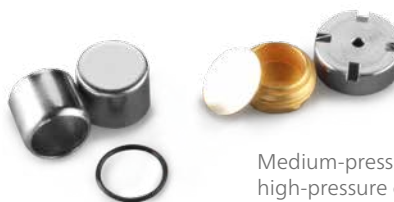

Medium-pressure crucibles (left) and high-pressure crucibles (right)



Al crucibles with lids

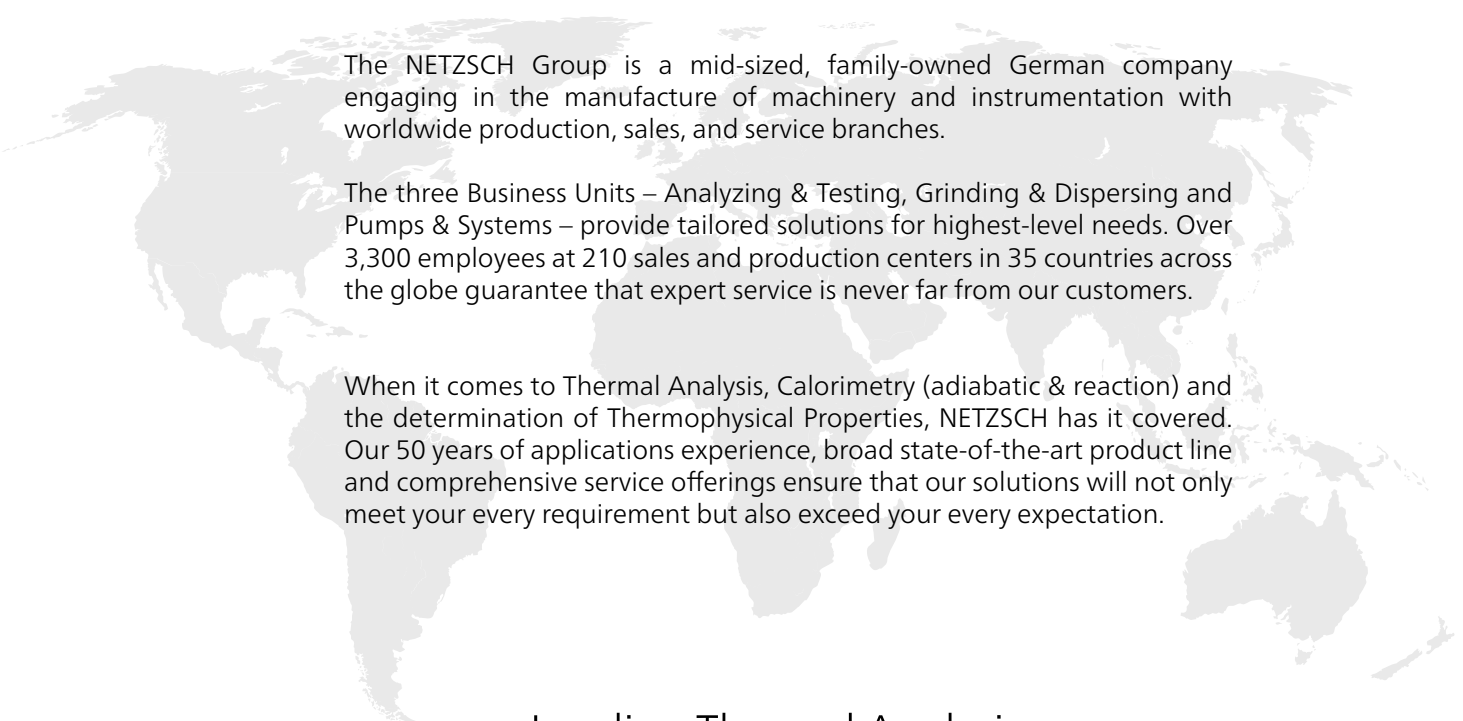

The NETZSCH Group is a mid-sized, family-owned German company engaging in the manufacture of machinery and instrumentation with worldwide production, sales, and service branches.

The three Business Units – Analyzing & Testing, Grinding & Dispersing and Pumps & Systems – provide tailored solutions for highest-level needs. Over 3,300 employees at 210 sales and production centers in 35 countries across the globe guarantee that expert service is never far from our customers.

When it comes to Thermal Analysis, Calorimetry (adiabatic & reaction) and the determination of Thermophysical Properties, NETZSCH has it covered. Our 50 years of applications experience, broad state-of-the-art product line and comprehensive service offerings ensure that our solutions will not only meet your every requirement but also exceed your every expectation.

Leading Thermal Analysis ■

NETZSCH-Gerätebau GmbH
Wittelsbacherstraße 42
95100 Selb
Germany
Tel.: +49 9287 881-0
Fax: +49 9287 881 505
at@netzsch.com

NETZSCH[®]

www.netzsch.com