

User Manual

Release 2.6

ECC-Aqu

Electrochemical test cell with reference electrode



The information in this manual has been carefully checked and believed to be accurate; however, no responsibility is assumed for inaccuracies.

EL-CELL GmbH maintains the right to make changes without further notice to products described in this manual to improve reliability, function, or design. EL-CELL GmbH does not assume any liability arising from the use or application of this product.

EL-CELL GmbH

Tempowerkring 8

21079 Hamburg - Germany

phone: +49 40 79012-737

fax: +49 40 79012-736

e-mail: info@el-cell.com

web: www.el-cell.com

Content

1 Product description	4
2 ECC-Aqu assembly	6
3 Disassembly and Cleaning	10
4 Unpacking.....	11
5 Technical data	12
6 Spare parts and consumables	13
7 Technical support.....	15
8 Warranty	15

1 Product description

The ECC cell design is the result of many years of experience and iterative improvement in battery and supercapacitor electrode testing. It is perfectly suited for voltammetry and impedance as well as cycle life testing.

The ECC-Aqu Electrochemical Cell is another member of the modular ECC test cell series, dedicated to the characterization of aqueous battery systems. All metal parts of the ECC-Aqu test cell which may come into contact with the electrolyte are made of gold. Other metals like platinum or nickel are optionally available, and may be easily replaced by the user. The ECC-Aqu cell is equipped with a reference pin assembly to control or monitor half-cell potentials.

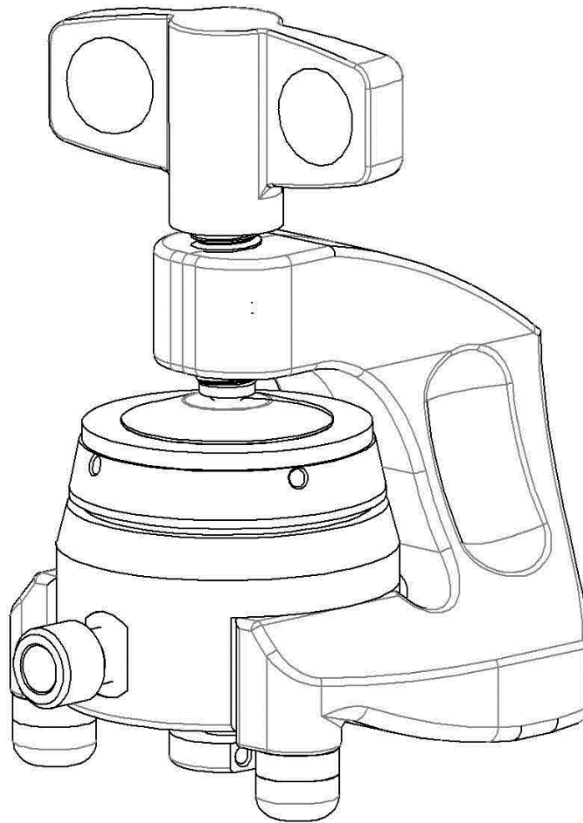

Features

- High precision 18 mm diameter sandwich geometry with <0.1 mm electrode concentricity
- Reliable ultra-low leakage sealing with PE seals
- Fast assembly and dismantling, and easy cleaning of cell components
- Electrodes are easily accessible for post-mortem analysis
- Reusable cell components except for PE sealing
- Adjustable, reproducible and homogeneous mechanical pressure on electrodes

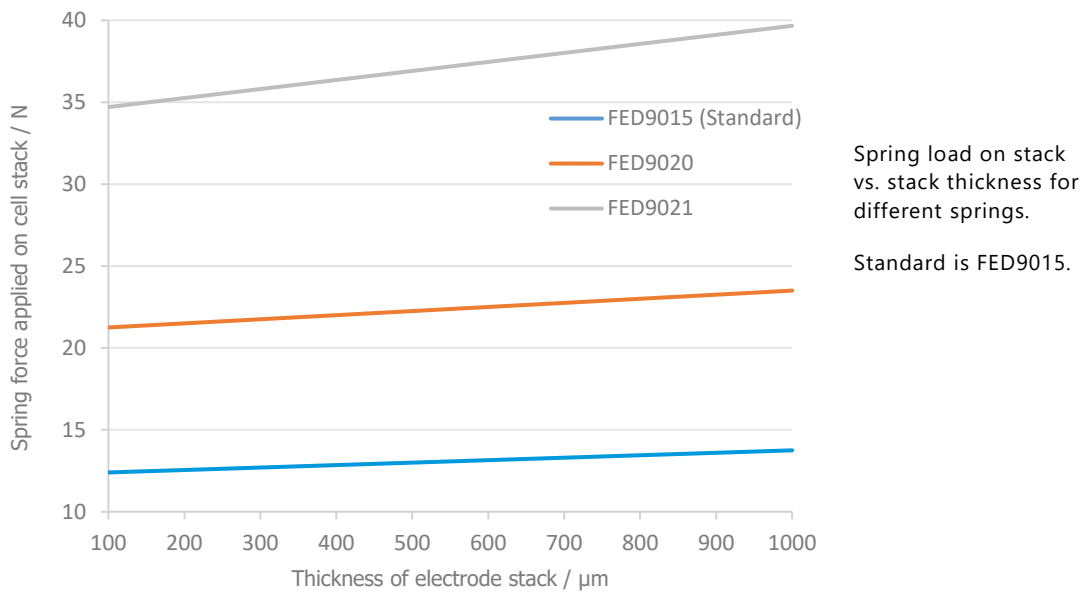

- Materials in media contact are gold and PEEK (other materials on request)
- Equipped with reference electrode pin for three-electrode operation
- Dedicated tools available to ease cell assembly and operation

2 ECC-Aqu assembly

The ECC electrochemical cell may be operated in several modes which differ in the size of the components used (diameter and thickness) and whether a reference electrode is used.

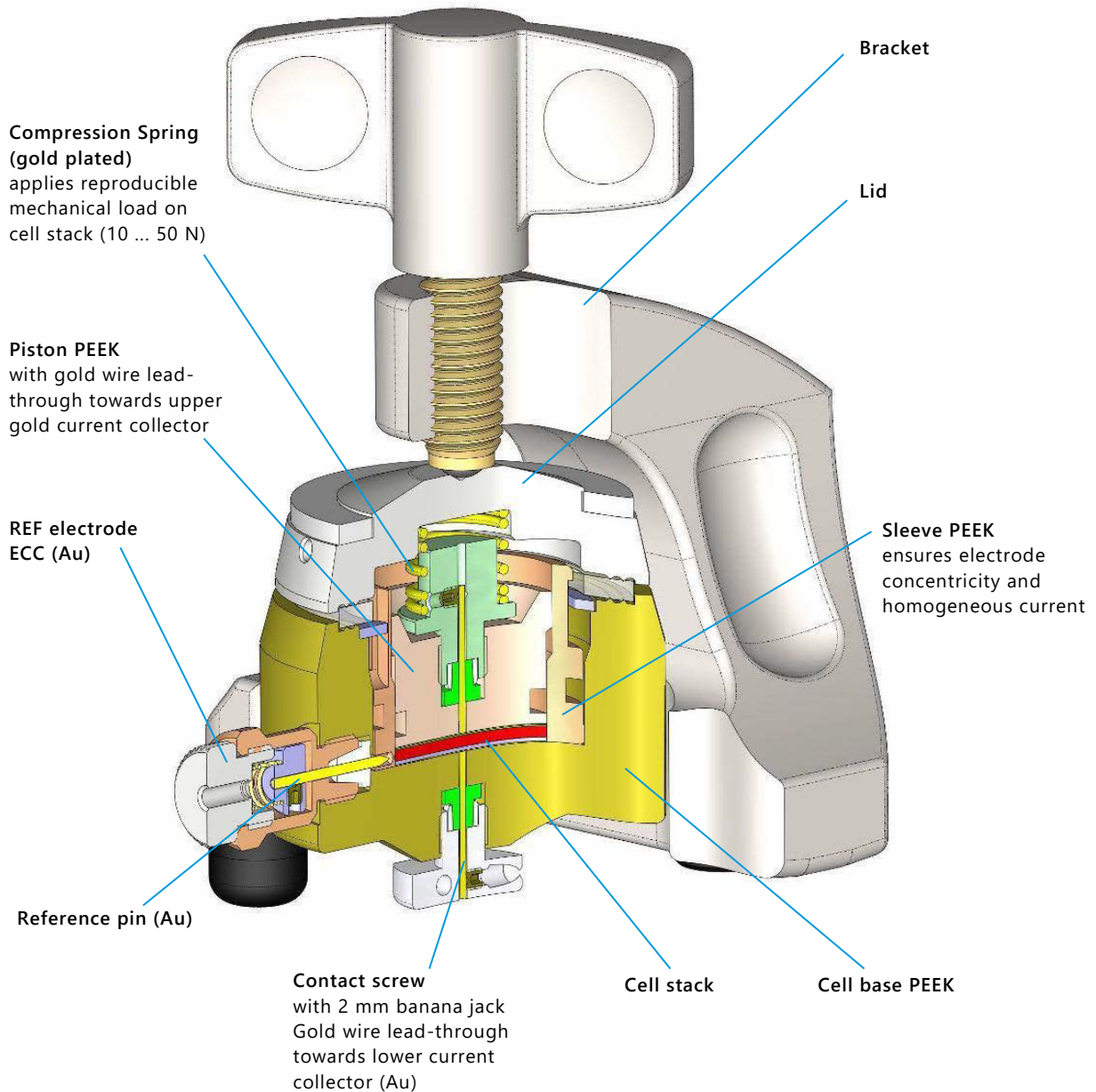

2.1 Safety precautions

Use proper safety precautions when using hazardous electrode materials and electrolytes. Wear protective glasses and gloves to protect you against electrolyte that may accidentally spill out during disassembly. Upon cell disassembly, dispose all materials properly.

2.2 Two-electrode assembly

In this mode the cell is assembled with a thick fiber cloth separator having the same 18 mm diameter as the two adjacent electrodes, and a thickness of between 0.2 and 2 mm. The cell is filled with the electrolyte during assembly by dropping a given volume of electrolyte directly onto the separator (0.05 to 0.5 cm³), depending on the separator and electrodes used). Only when applying the spring load upon final cell closure, a defined amount of electrolyte is squeezed out of the separator and soaks the two adjacent electrodes. The confinement of the cell stack by an insulating sleeve ensures a homogeneous current distribution.

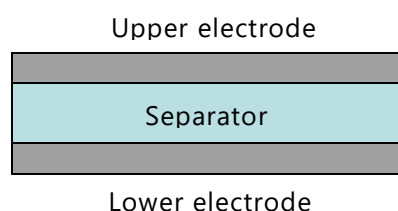

Assembly steps:

1. Close the side opening of the cell base with the provided PTFE plug.
2. Insert the Central Upper Piston into the Sleeve and hold the piston/sleeve assembly with the contact face of the piston pointing upwards.
3. Place the Current collector (Au), the working electrode and the glass fiber separator on top of the piston inside the sleeve.
4. Dispense a defined amount of electrolyte onto the separator.
5. Place the counter electrode and finally the second Current collector (Au) on top of the stack inside the sleeve.
6. Push the cell base over the assembly, press onto the piston, and turn the cell into the upright position.
7. Insert the spring and the PE seal.
8. Attach the cell lid, insert the cell into the bracket, and tighten the wing nut.

Note: The appropriate amount of electrolyte depends on the porosity and thickness of the components used, and thus has to be determined in pre-tests. The amount must be smaller than the absorption capacity of the separator in its uncompressed state. 0.5 mL of electrolyte

is a good starting value when using the 1.5 mm thick standard separator and electrodes of around 0.1 mm thickness.

2.3 Three electrode assembly

In the reference mode, a gold pin is making contact with the reference material which needs to be loaded upfront into the feed-through hole of the REF sleeve. The center of the 0.3 mm diameter REF hole is located 0.9 mm above the bottom of the cell base (see sketch below). Accordingly, the thickness of the lower electrode and the separator must be chosen so as to prevent a short between any of the two 18 mm electrodes and the reference in between.

Optionally, the reference pin itself can be used as a reference, e.g. when using a platinum wire as a pseudo reference. In this case, the reference pin must be sharpened so as to make sure that the pin gets into mechanical contact with the separator.

Note: The use of conventional reference electrodes with salt bridge is restricted by the narrow 1.6 mm diameter of the feed-through in the cell base.

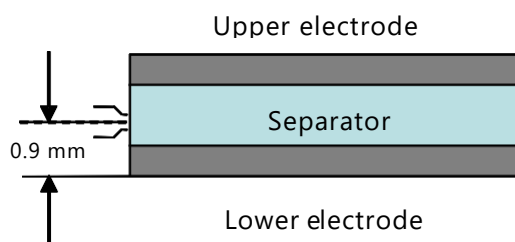

Assembly steps:

1. Load the feed-through hole of the REF sleeve with a small amount of the ductile reference material (such as PTFE bound activated carbon). When using powdery reference materials, we advise a different procedure. First, plug the narrow section of the hole with a small piece of glass fiber separator; only then load the powdery material into the hole. The glass fiber serves as an electrolyte wick (salt bridge), and holds the reference powder in place. . A dedicated tool, the ECC-RefLoad, is optionally available to ease this assembly step (<http://el-cell.com/products/tools-accessories/ecc-refload>)
2. Insert the Central Upper Piston into the REF sleeve and hold the piston/sleeve assembly with the contact face of the piston pointing upwards.
3. Place the Current collector (Au), the working electrode and the glass fiber separator on top of the piston inside the sleeve. Chose the thickness of the separator so as to avoid a short circuit between the reference and one of the two sandwich electrodes.
4. Dispense a defined amount of electrolyte onto the separator.
5. Place the counter electrode and finally the second Current collector (Au) on top of the stack inside the sleeve.

6. Push the cell base over the assembly, press onto the piston, and turn the cell into the upright position.
7. Mount the locking ring, the spring, and the PE seal.
8. Screw the REF electrode ECC (Au) into the side opening of the cell base.
9. Attach the cell lid, insert the cell into the bracket, and tighten the wing nut.

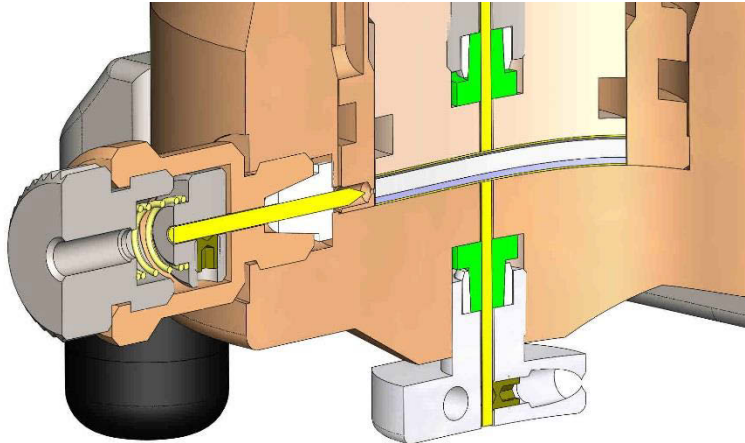

Detail view of the reference pin assembly
(reference material inside feed-through hole not shown)

2.4 Two-electrode assembly with thin separator

In this assembly mode the cell is assembled with a thin separator that is larger in diameter than the two adjacent electrodes so as to prevent a short circuit along the edge of the thin separator. An alignment tool is provided to ensure concentricity of the two sandwich electrodes upon assembly.

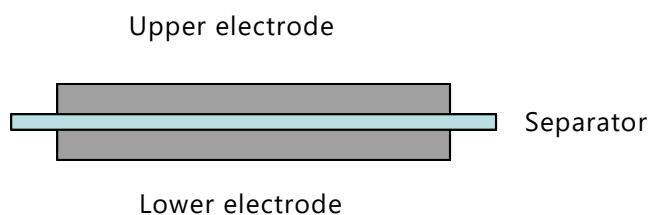

Assembly Steps:

1. Close the side opening of the cell base with the provided PTFE plug.
2. Insert the Central Upper Piston into the Sleeve and hold the piston/sleeve assembly with the contact face of the piston pointing upwards.
3. Place the Current collector (Au) disc and the working electrode on top of the piston inside the sleeve.

4. Dispense a defined amount of electrolyte onto the electrode. The amount of electrolyte must be sufficient to soak both electrodes and the separator. About 0.5 mL of electrolyte is appropriate for the provided 1.5 mm glass fiber separator and 0.1 mm thick electrodes.
5. Place the oversized (20 mm diameter) separator on top of the wetted electrode. Make sure that the electrode is fully covered by the separator.
6. Attach the provided Adjustment Tool and insert the counter electrode and finally the second Current collector (Au) on top of the stack.
7. Detach the Adjustment Tool.
8. Push the cell base over the assembly, press onto the piston, and turn the cell into the upright position.
9. Mount the spring and the PE seal.
10. Attach the cell lid, insert the cell into the bracket, and tighten the wing nut.

3 Disassembly and Cleaning

After use, disassemble the test cell in the reverse order of assembly. Note that the reference pin **MUST** be detached before the REF sleeve can be removed. Dispose electrodes and electrolyte properly. Clean wetted cell parts with deionized water and/or other appropriate detergent wash and solvent. PEEK sleeve, cell base and plunger may be additionally cleaned in an ultrasonic bath. After cleaning with water, dry parts with compressed air. If using the test cell with aprotic electrolytes, parts must be dried overnight at 80°C under vacuum before building a new cell. This drying step is essential for the cell base and sleeve, as the PEEK polymer may absorb water.

Notes:

- Protect yourself against chemical hazards. Electrolyte may spill out during cleaning. Electrode materials and electrolyte may react with ambient atmosphere or solvents used for cleaning. Wear appropriate protection equipment, goggles and gloves.
- Clean all cell parts right after disassembly. Leaving cell parts in contact with ambient atmosphere while still being wetted with electrolyte may result in severe corrosion.

Sleeve removing tool



The REF-sleeve can be easily removed with the sleeve removing tool. First detach the Reference-electrode assembly, then position the tool beneath the rim of the sleeve and lift it out of the cell base.

NOTE: Leaving cell parts in contact with ambient atmosphere while still being wetted with electrolyte may result in severe corrosion.

4 Unpacking

Check the contents of the packages against the list given below to verify that you have received all of the components. Contact the factory if anything is missing or damaged. **NOTE:** Damaged shipments must remain with the original packaging for freight company inspection.

List of Components

ECC-Aqu test cell, fully equipped for use with and without reference

Accessories-kit

- Reference pin (Au) [ECC1-00-0010-C](#)
- Sleeve (Ref) [ECC1-00-0058-B](#)
- Adjustment tool (for ECC-Aqu) [ECC1-00-0091-A](#)
- Locking washer [ECC1-00-0061-A](#)
- Allen wrench 0.9 mm [WZG9005](#)
- Current collector (Au) [ECC1-00-0069-A](#)
- Sleeve removing tool [ECC1-00-0092-A](#)
- PE seal (10 pcs.) [ECC1-00-0053-A/X](#)
- Glass fiber separator 18 x 1.55 mm (10 pcs.) [ECC1-01-0012-C/X](#)

5 Technical data

- Height: 90 mm
Width: 54 mm
Depth: 70 mm
- Weight: 600 g
- Temperature operation range: -40 to +80 °C
- Electrolyte volume: 0.05 to 0.5 cm³ (depending on porosity and thickness of electrodes and separator used)

6 Spare parts and consumables

ECC-Aqu test cell

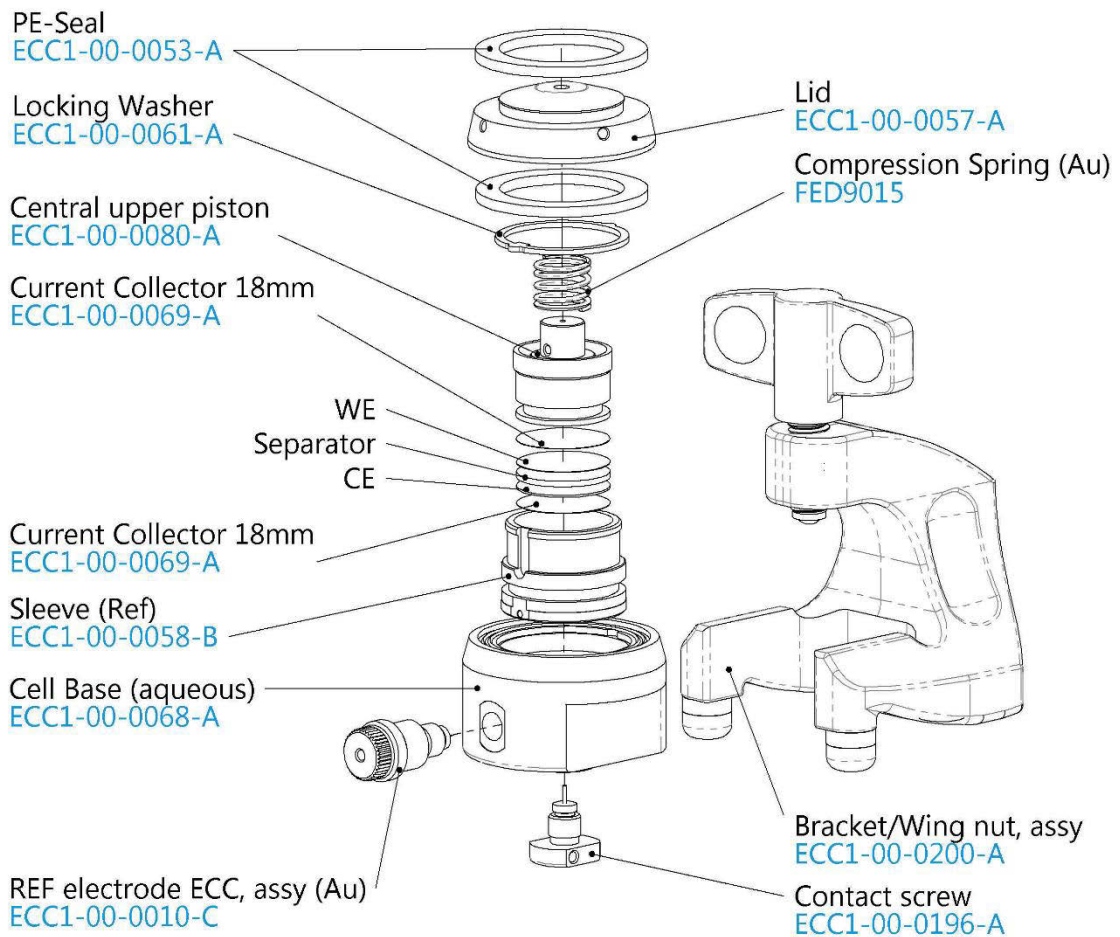
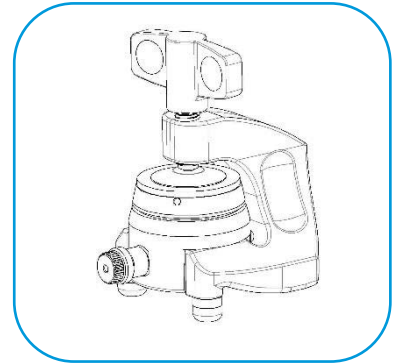

Reference electrode ECC (Au)

ECC1-00-0010-C

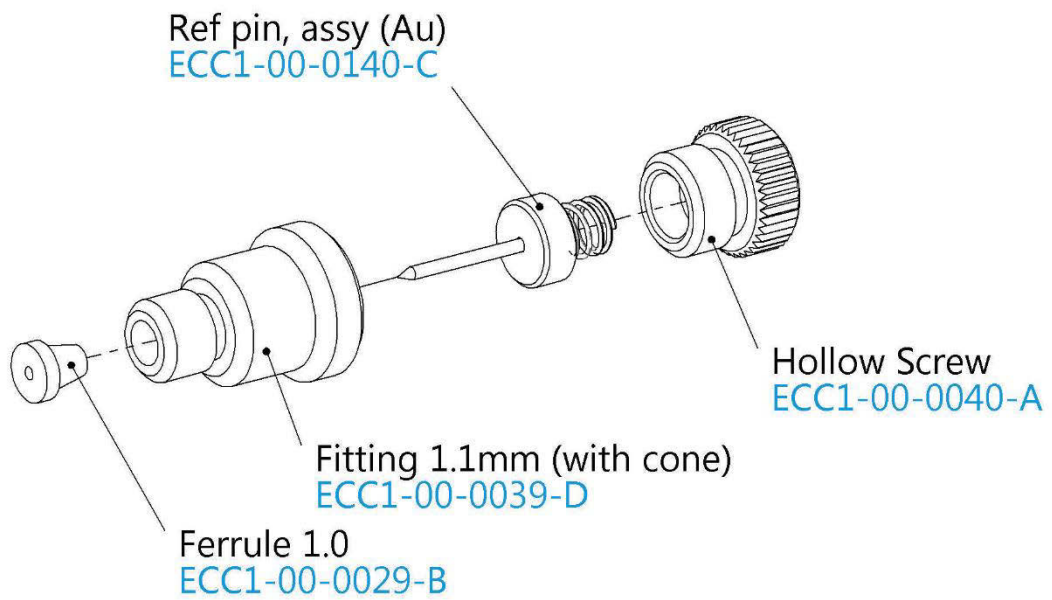
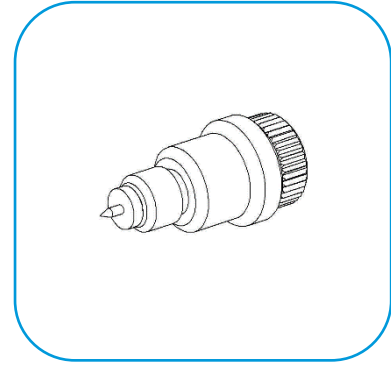

7 Technical support

Technical support for this product is exclusively provided by EL-CELL GmbH.

EL-CELL GmbH

Tempowerkring 8
21079 Hamburg - Germany

phone: +49 40 79012-737

fax: +49 40 79012-736

e-mail: info@el-cell.com

web: www.el-cell.com

8 Warranty

For a period of one year from the date of shipment, EL-CELL GmbH (hereinafter Seller) warrants the goods to be free from defect in material and workmanship to the original purchaser. During the warranty period, Seller agrees to repair or replace defective and/or nonconforming goods or parts without charge for material or labor, or, at the Seller's option, demand return of the goods and tender repayment of the price. Buyer's exclusive remedy is repair or replacement of defective and nonconforming goods, or, at Seller's option, the repayment of the price.

Seller excludes and disclaims any liability for lost profits, personal injury, interruption of service, or for consequential incidental or special damages arising out of, resulting from, or relating in any manner to these goods.

This Limited Warranty does not cover defects, damage, or nonconformity resulting from abuse, misuse, neglect, lack of reasonable care, modification, or the attachment of improper devices to the goods. This Limited Warranty does not cover expendable items. This warranty is void when repairs are performed by a non-authorized person or service center. At Seller's option, repairs or replacements will be made on site or at the factory. If repairs or replacements are to be made at the factory, Buyer shall return the goods prepaid and bear all the risks of loss until delivered to the factory. If Seller returns the goods, they will be delivered prepaid and Seller will bear all risks of loss until delivery to Buyer. Buyer and Seller agree that this Limited Warranty shall be governed by and construed in accordance with the laws of Germany.

The warranties contained in this agreement are in lieu of all other warranties expressed or implied, including the warranties of merchantability and fitness for a particular purpose.

This Limited Warranty supersedes all prior proposals or representations oral or written and constitutes the entire understanding regarding the warranties made by Seller to Buyer. This Limited Warranty may not be expanded or modified except in writing signed by the parties hereto.