



Pascal 2010 SD (10 m³/h)

Two-stage rotary vane pump of 10 m³/h,
Standard version





Similar Image

Pascal 2010, SD version, 1-phase motor, 180-254 V, 50 Hz/60 Hz, CE/UL/CSA

SD, I, C1 versions are delivered with mineral oil, and C2 versions are prepared for operation with PFPE oil but fluid must be ordered separately

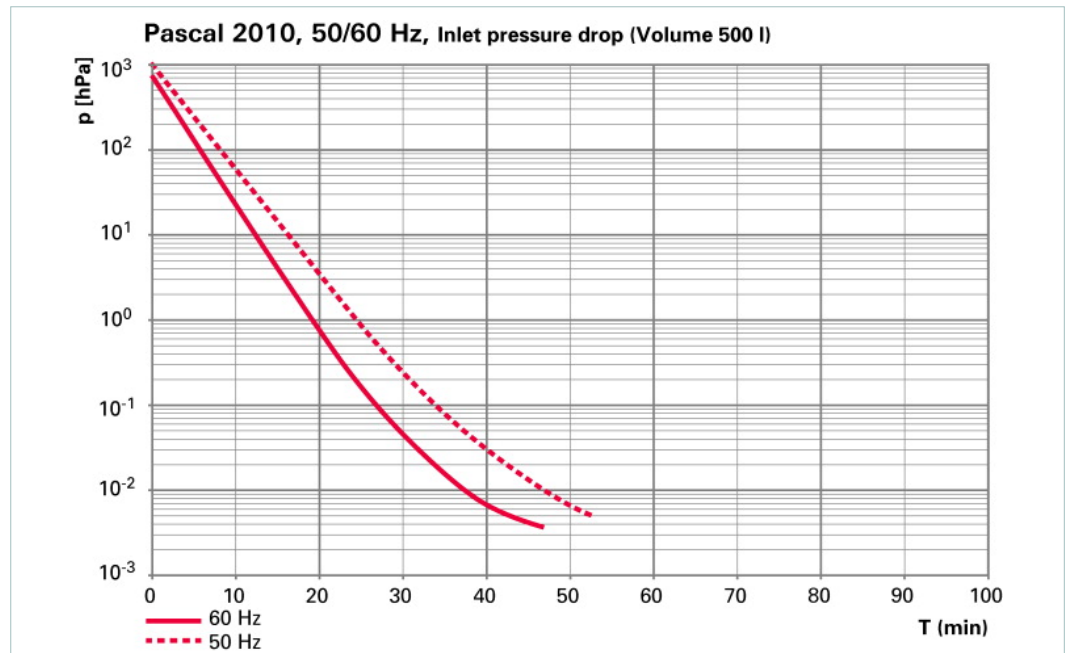
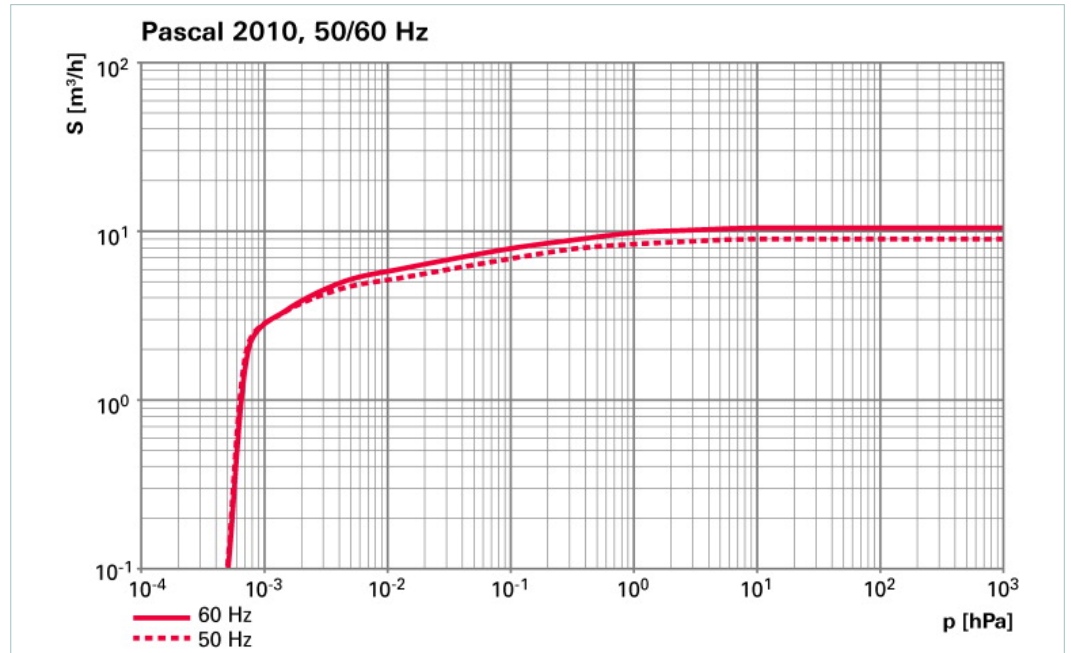

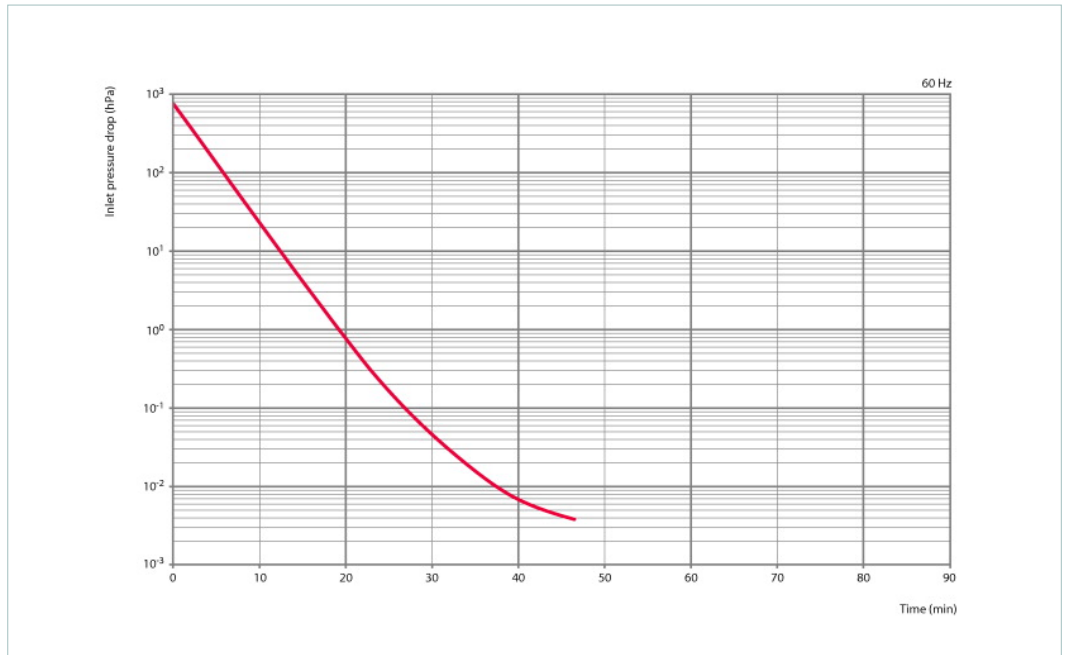

Dimensions

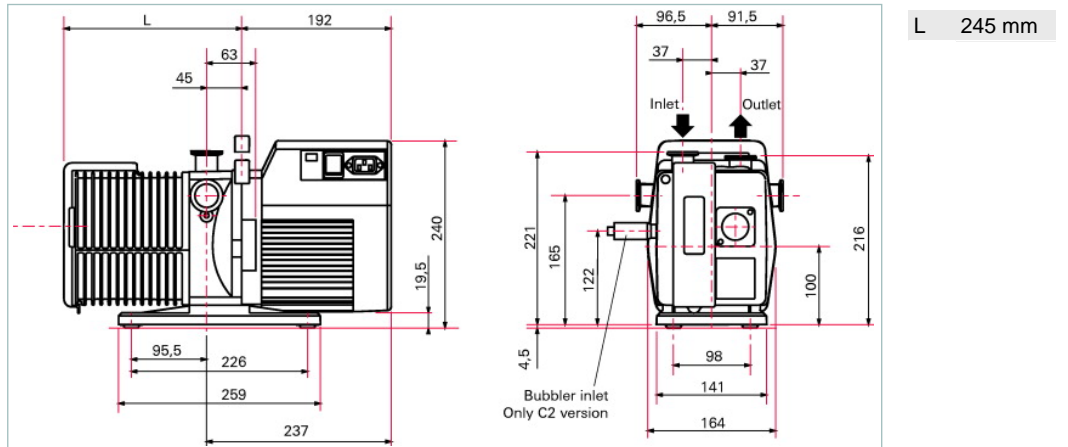

Technical Data	Pascal 2010, SD version, 1-phase motor, 180-254 V, 50 Hz/60 Hz, CE/UL/CSA
Flange (in)	DN 25 ISO-KF
Flange (out)	DN 25 ISO-KF
Mains requirement: voltage 50 Hz	180-254 V
Mains requirement: voltage 60 Hz	180-254 V
Operating fluid	Mineral oil
Pumping speed at 50 Hz	9 m ³ /h
Pumping speed at 60 Hz	10.5 m ³ /h
Rated power 50 Hz	0.45 kW
Rated power 60 Hz	0.55 kW
Ultimate pressure	5 · 10 ⁻⁴ hPa 3.75 · 10 ⁻⁴ Torr 5 · 10 ⁻⁴ mbar
Ultimate pressure with gas ballast	1 · 10 ⁻² hPa 7.5 · 10 ⁻³ Torr 1 · 10 ⁻² mbar
Version	Standard
Weight	26 kg 57.32 lb

Ultimate pressure according to PNEUROP

Order number	
Pascal 2010 SD (10 m ³ /h)	210SDMHM

Accessories	
Accessories	
Automatic gas ballast AGB 4, 100 V, 50/60 Hz	104088
Automatic gas ballast AGB 4, 115 V	104087
Automatic gas ballast AGB 4, 200 V, 50/60 Hz	104366
Automatic gas ballast AGB 4, 230 V, 50/60 Hz	104086
Automatic gas ballast AGB 4, 24 VDC	104089
Condensate trap CT 25	104201
Inlet dust filter DFT 25	104202
Liquid nitrogen trap LNT 25 P1	786346
Liquid nitrogen trap LNT 25 S	104197
Oil drain kit ODK 1	104360
Oil drain kit ODK 2, 100 V, 50/60 Hz	104363
Oil drain kit ODK 2, 115 V, 60 Hz	104362
Oil drain kit ODK 2, 200 V, 50/60 Hz	104364
Oil drain kit ODK 2, 230 V, 50/60 Hz	104361
Oil drain kit ODK 2, 24 VDC	104365
Oil level switch OLS 4	104376
Oil mist eliminator OME 25 HP	104199
Oil mist eliminator OME 25 HP+	108341
Oil mist eliminator OME 25 S	104200
Sorption trap ST 25 S	104107

**Vacuum solutions
from a single source**

Pfeiffer Vacuum stands for innovative and custom vacuum solutions worldwide, technological perfection, competent advice and reliable service.

**Complete range
of products**

From a single component to complex systems:
We are the only supplier of vacuum technology
that provides a complete product portfolio.

**Competence in
theory and practice**

Benefit from our know-how and our portfolio of training
opportunities! We support you with your plant layout
and provide first-class on-site service worldwide.

**Are you looking for a
perfect vacuum solution?
Please contact us:**

Pfeiffer Vacuum GmbH
Headquarters · Germany
T +49 6441 802-0
info@pfeiffer-vacuum.de
www.pfeiffer-vacuum.com