

# User Manual

Release 2.4

## Electrochemical Test Cell ECC-Opto-Std



20. October 2015

The information in this manual has been carefully checked and believed to be accurate; however, no responsibility is assumed for inaccuracies.

EL-CELL GmbH maintains the right to make changes without further notice to products described in this manual to improve reliability, function, or design. EL-CELL GmbH does not assume any liability arising from the use or application of this product.

**EL-CELL GmbH**

Tempowerkring 8

21079 Hamburg - Germany

**phone:** +49 (0)40 790 12 733

**fax:** +49 (0)40 790 12 736

**e-mail:** [info@el-cell.com](mailto:info@el-cell.com)

**web:** [www.el-cell.com](http://www.el-cell.com)

# Content

- 1 Product Description..... 4**
- 2 Features ..... 6**
- 3 Safety Precautions ..... 7**
- 4 Unpacking ..... 7**
- 5 Assembly and Connection..... 9**
- 6 Disassembly and Cleaning ..... 12**
- 7 X-Ray Experiments..... 13**
- 8 Further Kits..... 15**
- 9 Components ECC-Opto-Std ..... 16**
- 10 Spare Parts ..... 17**
- 11 Consumables ..... 18**
- 12 Technical Support ..... 19**
- 13 Warranty ..... 19**

# 1 Product Description

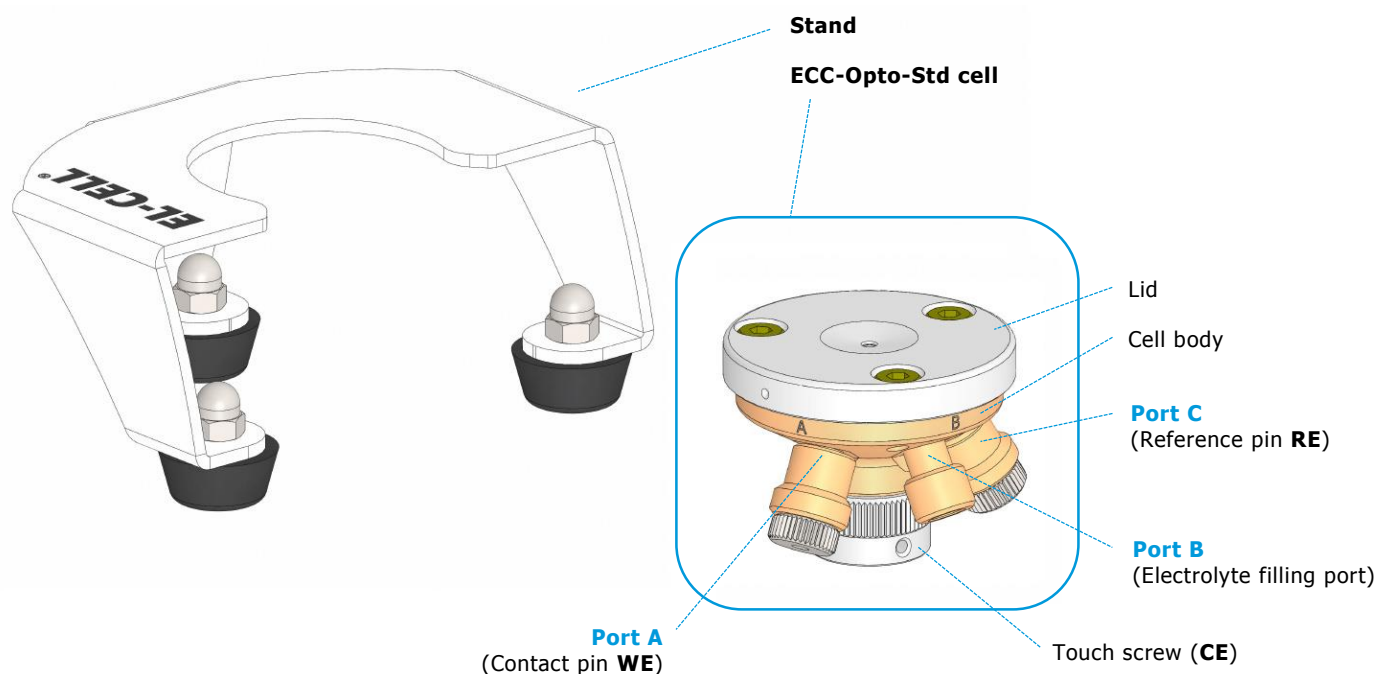

The ECC-Opto-Std test cell serves to monitor the optical properties of an electrode material in the course of electrochemical charging. For this purpose, the working electrode (**WE**) material, which is supported on a meshed or holed current collector, is placed right below the optical window. This WE is sandwiched from below with a glass fiber separator and an appropriate counter electrode, (**CE**).

This way, the optical instrument "looks" from the top through the optical window onto the backside of the electrode material. Typical instrumentations include optical and confocal Raman microscopy in the reflection mode. A re-fitting kit for X-ray is available as an option (view page 13).

The maximum diameter of the working electrode WE is 10 mm, while that of the inspection hole is 1 mm (optional up to 10 mm). The cell is equipped with a reference electrode pin for 3-electrode operation.

# Working principle of the ECC-Opto-Std:

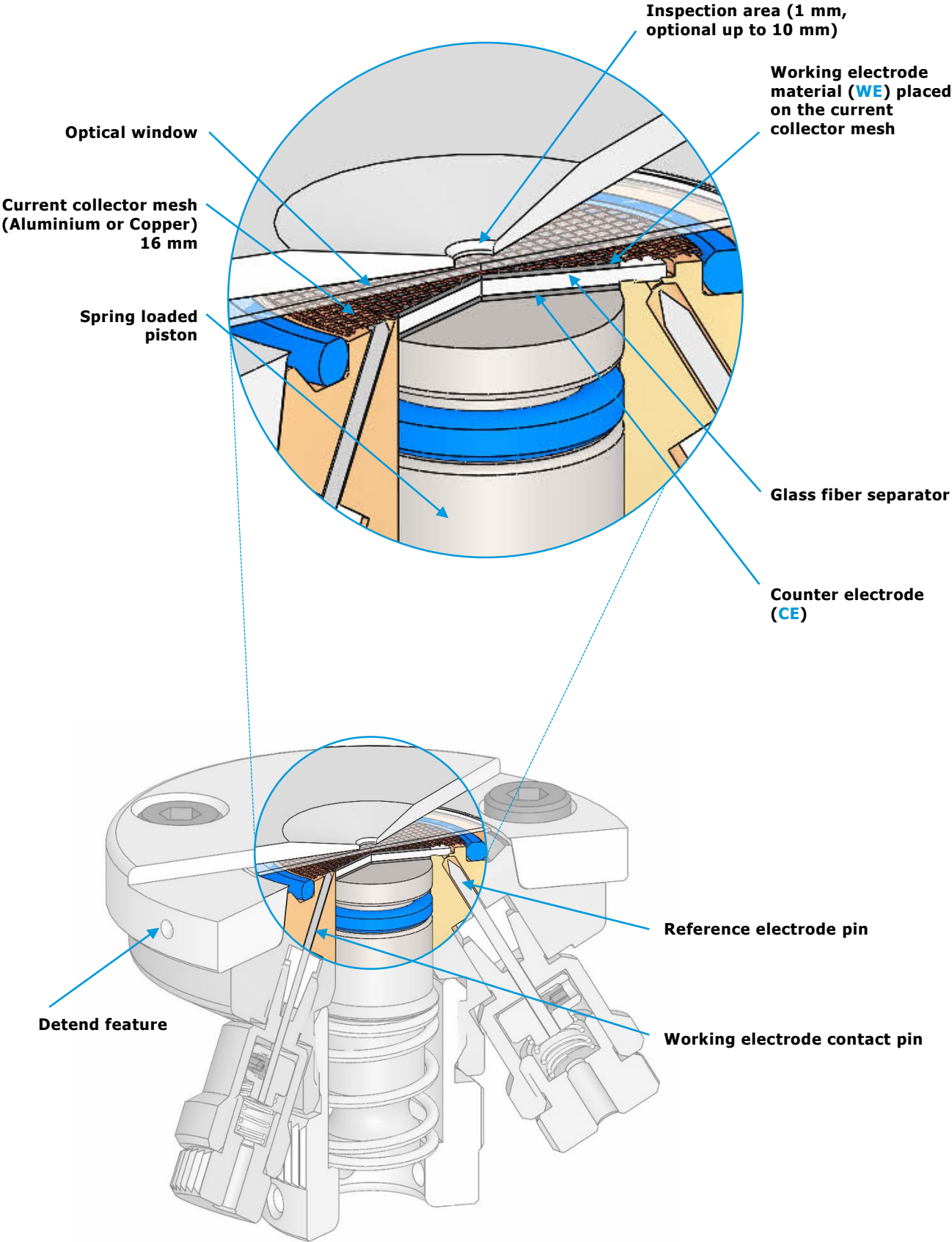

## 2 Features

- 2- and 3-electrode cell with optical window for aprotic electrochemistry.
- Materials in media contact are stainless steel 1.4404, PEEK and EPDM
- The backside of the working electrode material can be observed through the optical window on top. Inspection area diameter is 1 mm. Other diameters up to 10 mm available.
- Typically used in combination with optical or Raman microscopy in the reflection mode. X-ray option with Beryllium window available.
- The window is made of optical glass. Sapphire, Beryllium and Kapton® windows are available on request.
- Working electrodes can be single crystals or grains, powder samples and free-standing electrodes (applied onto current collector mesh). Maximum electrode diameter is 10 mm.
- Easy and clean electrolyte filling via the vacuum (syringe) method. All necessary equipment is included.
- Cell assembly and filling are to be carried out inside a glove box. Once sealed, the cell may be operated outside the box at ambient atmosphere.
- Small and defined electrolyte volume down to 0.1 cm<sup>3</sup> due to minimized dead volume
- Connection to potentiostat/battery tester via 2 mm banana sockets, adapters for 4 mm banana sockets are included
- Temperature operation range -20 to +70 °C

### Dimensions of the ECC-Opto-Std (mm):

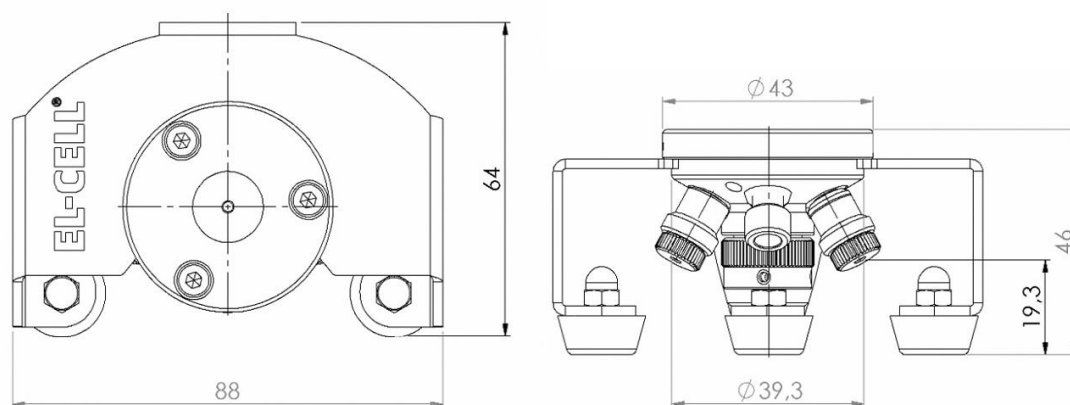

## 3 Safety Precautions

Use proper safety precautions when using hazardous electrode materials and electrolytes. Wear protective glasses and gloves to protect you against electrolyte that may accidentally spill out during filling and disassembly. Upon cell disassembly, dispose all materials properly. Metallic lithium and some insertion compounds may decompose heavily in contact with water and other solvents, and can cause fire.

**X-ray option (view page 13):** Beryllium is highly toxic and can cause cancer. Take proper precautions when handling the Beryllium window. Avoid direct contact with skin. Carefully collect and dispose properly any Beryllium fragments when accidentally breaking the window.



## 4 Unpacking

Check the contents of the packages against the list given below to verify that you have received all of the components. Contact the factory if anything is missing or damaged.

**NOTE:** Damaged shipments must remain with the original packaging for freight company inspection.

### List of Components:

1. ECC-Opto-Std test cell with stand, fully equipped for use in both 2-electrode and 3-electrode (reference) configuration in aprotic electrolytes [ECC1-00-0150-A](#)
2. ECC-Opto cell cable [ECE1-00-0075-A](#)

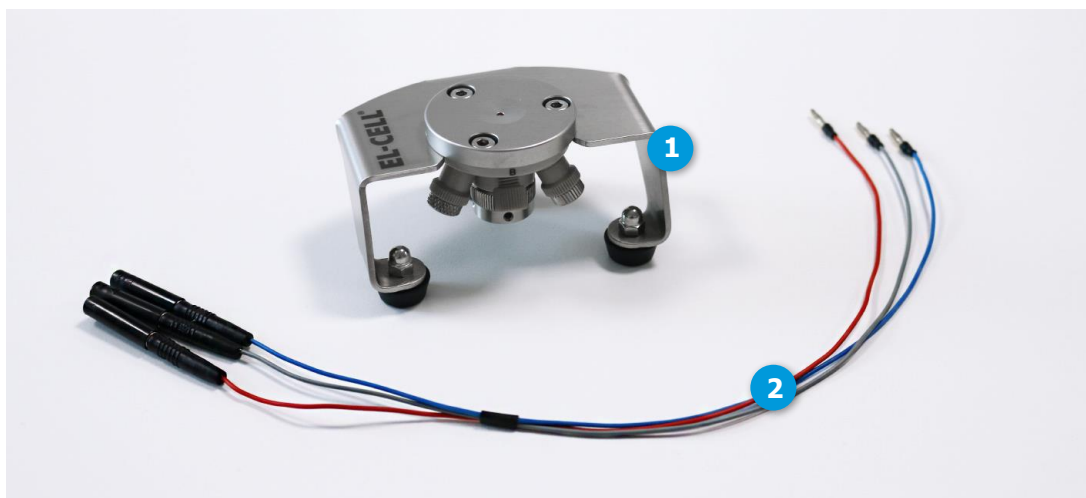

### 3. Accessories Kit: [ECC1-00-0306-A](#)

1. Glass windows (5 pieces) [LAB0018/V](#)
2. Glass fiber separators (5 pieces) [ECC1-01-0012-J/V](#)
3. Feed wire, assy [ECC1-00-0010-F](#)
4. Current collector mesh, copper (5 pieces) [ECC1-00-0328-A/V](#)
5. Current collector mesh, aluminium (5 pieces) [ECC1-00-0328-B/V](#)
6. Filling tube with syringe (5 ml) for vacuum filling [ECC1-01-0001-A](#)
7. O-Ring 6.75 mm x 1.78 mm [DIC9013](#)
8. O-Ring 16 mm x 1.8 mm [DIC9012](#)
9. Hex wrench 0.9 mm [WZG9005](#)
10. Spherical hex screw driver 3 mm [WZG9002](#)





## 5 Assembly and Connection

Generally, all assembly steps are to be carried out in inert glove box atmosphere. All components used are to be dried upfront in a vacuum oven at 80°C for at least 12 hours. Once fully assembled, the cell is hermetically sealed so that it may be operated in ambient atmosphere.

The test cell can be used in either 2-electrode or 3-electrode (reference) configuration. In the following, the cell assembly is described for operation with graphite powder as the working electrode and lithium metal reference electrode.

### Assembly:

1. By means of the optionally available [ECC-RefLoad](#), press a small piece of lithium metal into **port C** so that the Lithium metal just appears at the upper narrow end of the feed-through hole. Skip this initial step if working without reference electrode.
2. Push the counter electrode piston into the cell body to the uppermost position.
3. Pull the piston slightly back, and insert the Lithium counter electrode (max. 10 mm in diameter, max. 1 mm thick)
4. Put the provided glass fiber separator on top.
5. Place a small amount, a few milligrams, of graphite powder onto the center of the separator. An fan-less ionizing device operated in close proximity helps to prevent the build-up of electrostatic excess charge.
6. Cover the graphite sample material with one of the provided 16 mm current collectors meshes. The graphite powder penetrates into the mesh and so gets into direct contact with the window on top.
7. Insert the upper O-Ring seal (16 x 1.8 mm) into the cell body, and place the optical window on top. Make sure that the window is in the center position.
8. Attach the lid and fasten the three socket screws.
9. Attach the **WE** contact pin to **port A**.
10. Attach the reference pin to the reference port. Plug the reference port if working without reference electrode.
11. Attach the touch screw from below and raise it to the uppermost position; then turn the touch screw back (counter clockwise) by about 30°.
12. Fill the cell with electrolyte according to the following procedure.
  - Connect the provided filling tube to **port B**.
  - Charge a 5 ml syringe with ca. 0.5 ml of electrolyte. **NOTE:** We recommend single-use PP plastic syringes with low friction silicone pistons.

- Connect the syringe to the Luer adapter of the filling tube.
- Pull the syringe piston back to evacuate the cell. Hold the piston a few seconds in the strained position.



- Make sure that the tip of the syringe points downwards. Then release the piston so that the electrolyte is sucked into the cell by the previously applied vacuum. **NOTE:** Never pressurize the cell during the filling procedure.
- Repeat the two previous steps to complete filling.
- Remove the filling tube and close port B with the second WE contact pin.

**13.** Insert the cell into the stand.

If a free-standing (unsupported) electrode film is used as the working electrode, the above steps 5 and 6 are to be replaced as follows.

14. Connect the cell to the cell cable as shown in the picture below.

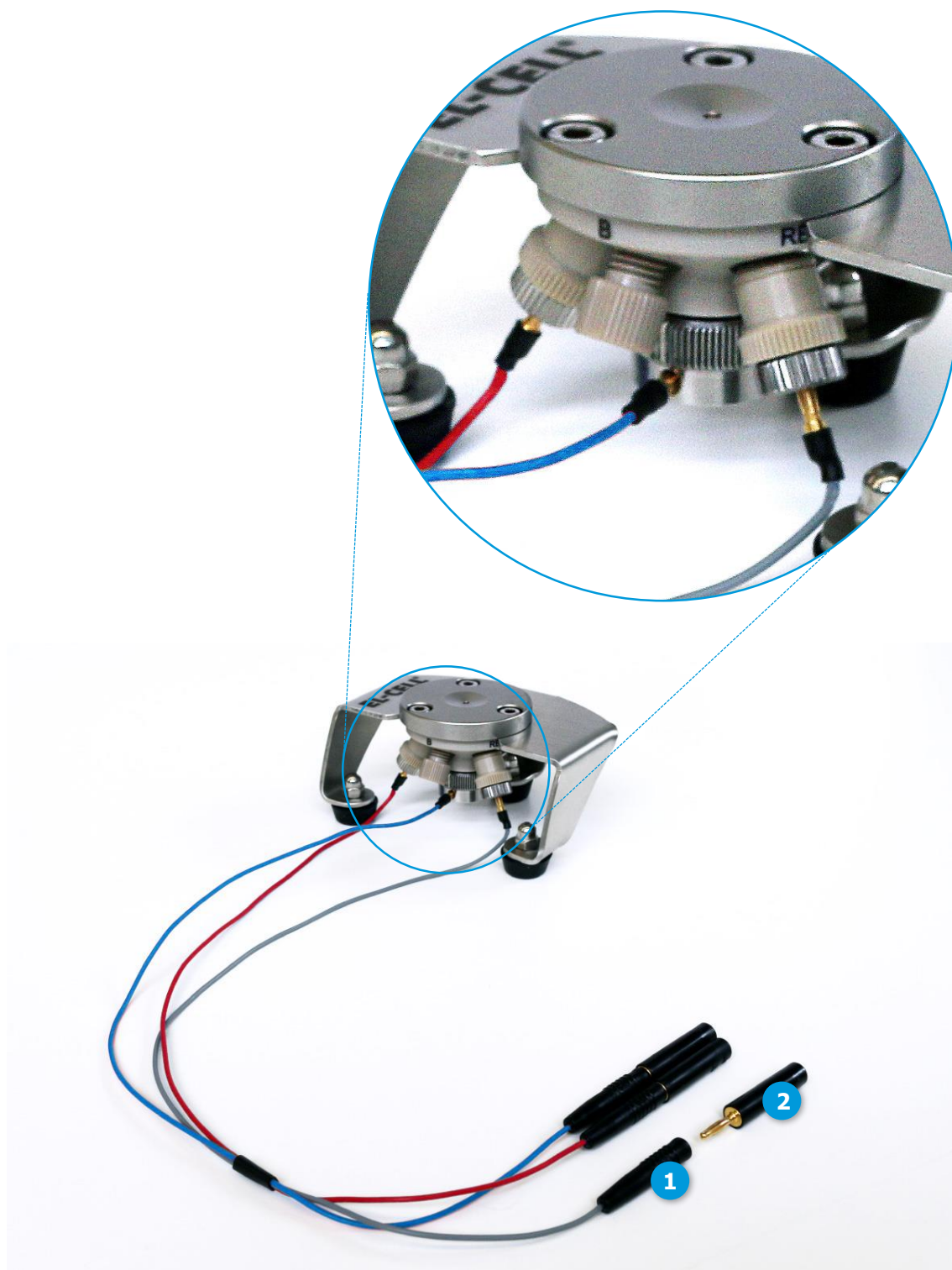

15. Connect your potentiostat to the 2 mm sockets (1) of the cell cable (**grey: REF**; **red: WE**; **blue: CE**). Adapters (2) are provided for connection to 4 mm banana plugs.

## Different spring forces in relation to stack thickness:

A compression spring exerts the mechanical pressure on the cell stack. Different springs with a nominal pressure of 10, 20 and 30 N are available. The applied pressure slightly depends on the thickness of the cell stack.

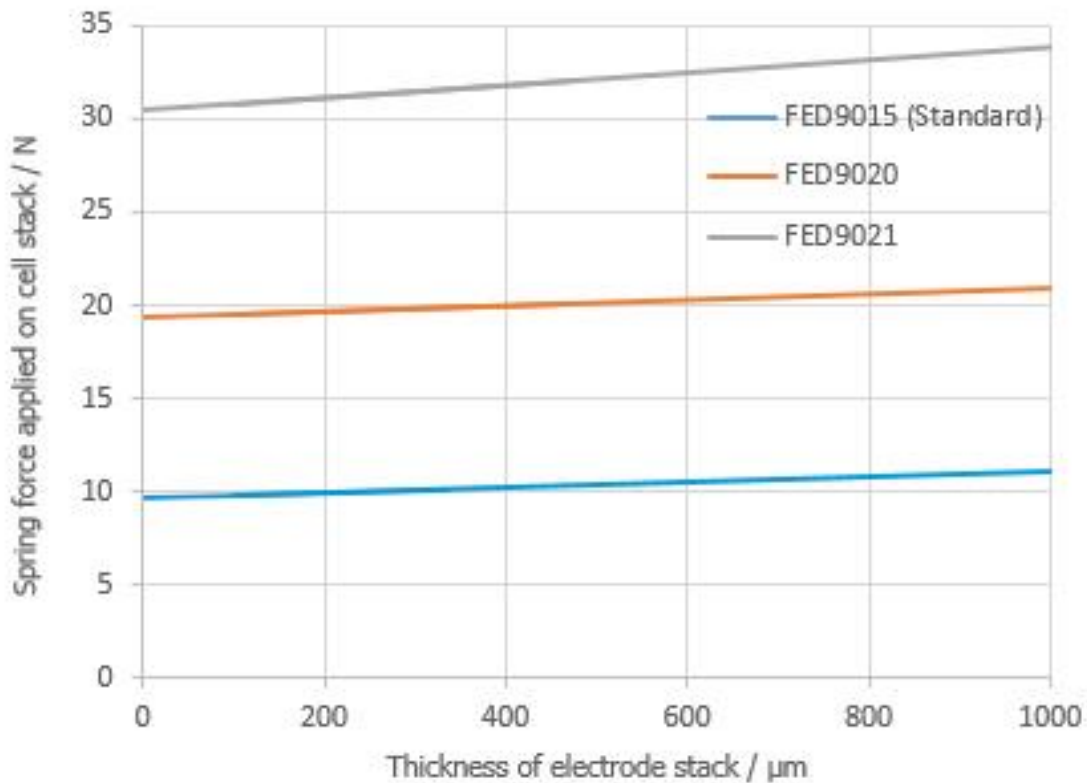

## 6 Disassembly and Cleaning

Right after use, disassemble the cell in the reverse order of assembly. All chemicals used have to be disposed properly. All wetted parts are to be cleaned with water and/or other appropriate solvents. All parts are to be dried immediately after cleaning at 80°C.

**NOTE:** Leaving cell parts in contact with ambient atmosphere while still being wetted with electrolyte may result in severe corrosion.

## 7 X-Ray Experiments

For X-ray experiments, the optional **XRD Kit** is available ([ECC1-00-0156-B](#)). The XRD-kit comprises a Beryllium window ([ECC1-00-0222-A](#)) and a modified cell lid ([ECC1-00-0127-C](#)). The lid features a 10 mm inspection hole and a 10 mm wide groove that allows for a viewing angle onto the sample surface as low as 8°.

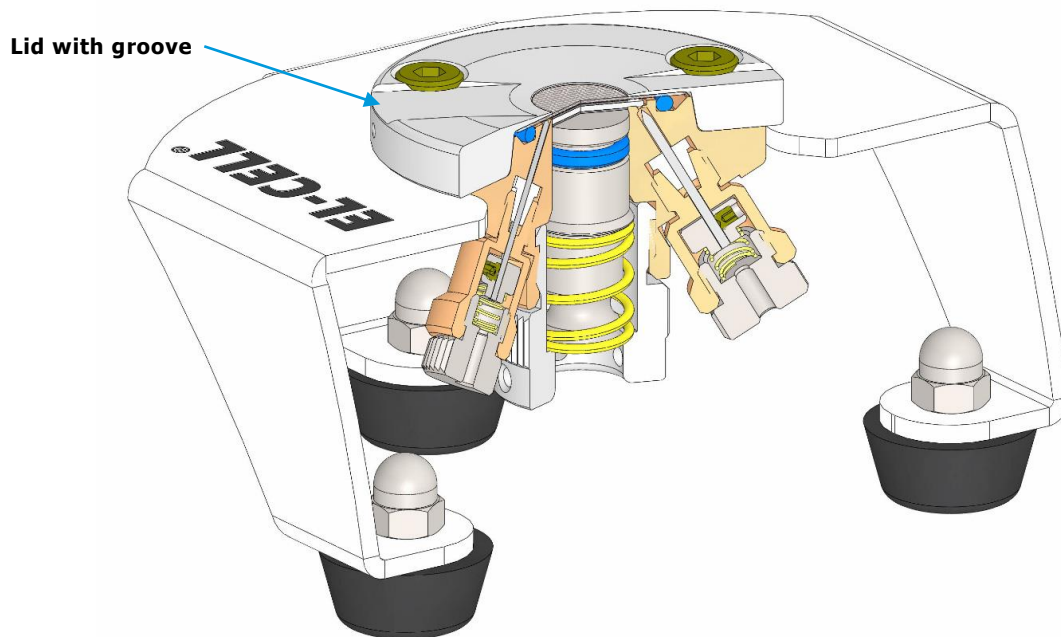

### List of Components X-ray Kit:

[ECC1-00-0156-B](#)

1. Beryllium window (22 x 0.2 mm) [ECC1-00-0222-A](#)
2. Lid XRD [ECC1-00-0127-C](#)



## Viewing angle X-Ray Kit:

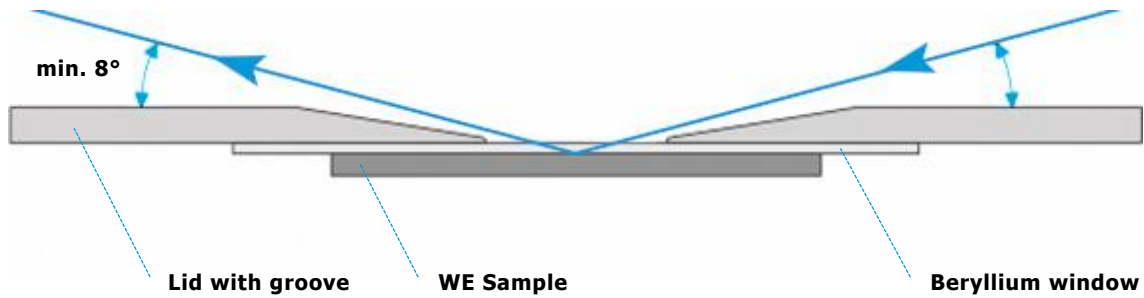

At very positive potentials, the Beryllium window may suffer from oxidation. In this case we recommend placing a thin insulation layer, e.g. a small piece of polyethylene foil (15 mm in diameter, 10  $\mu\text{m}$  thick), in between the holed current collector and the Beryllium window.

**Beryllium is highly toxic and can cause cancer.** Take proper precautions when handling the Beryllium window. Avoid direct contact with skin. Carefully collect and dispose properly any Beryllium fragments when accidentally breaking the window.



## 8 Further Kits

### Components Sapphire Kit:

ECC1-00-0156-C

1. Sapphire window (22 x 0.3 mm) [ECC1-00-0149-A](#)
2. Lid Sapphire [ECC1-00-0127-B](#)

### Components Zinc Selenide Kit:

ECC1-00-0156-D

1. Zinc Selenide window (22 x 0.3 mm) [ECC1-00-0250-B s](#)
2. Lid Zinc Selenide [ECC1-00-0127-E](#)

### Components Calciumfluoride Kit:

ECC1-00-0156-E

1. Calciumfluorid window (22 x 0.3 mm) [ECC1-00-0250-C](#)
2. Lid Calciumfluorid [ECC1-00-0127-E](#)

## 9 Components ECC-Opto-Std

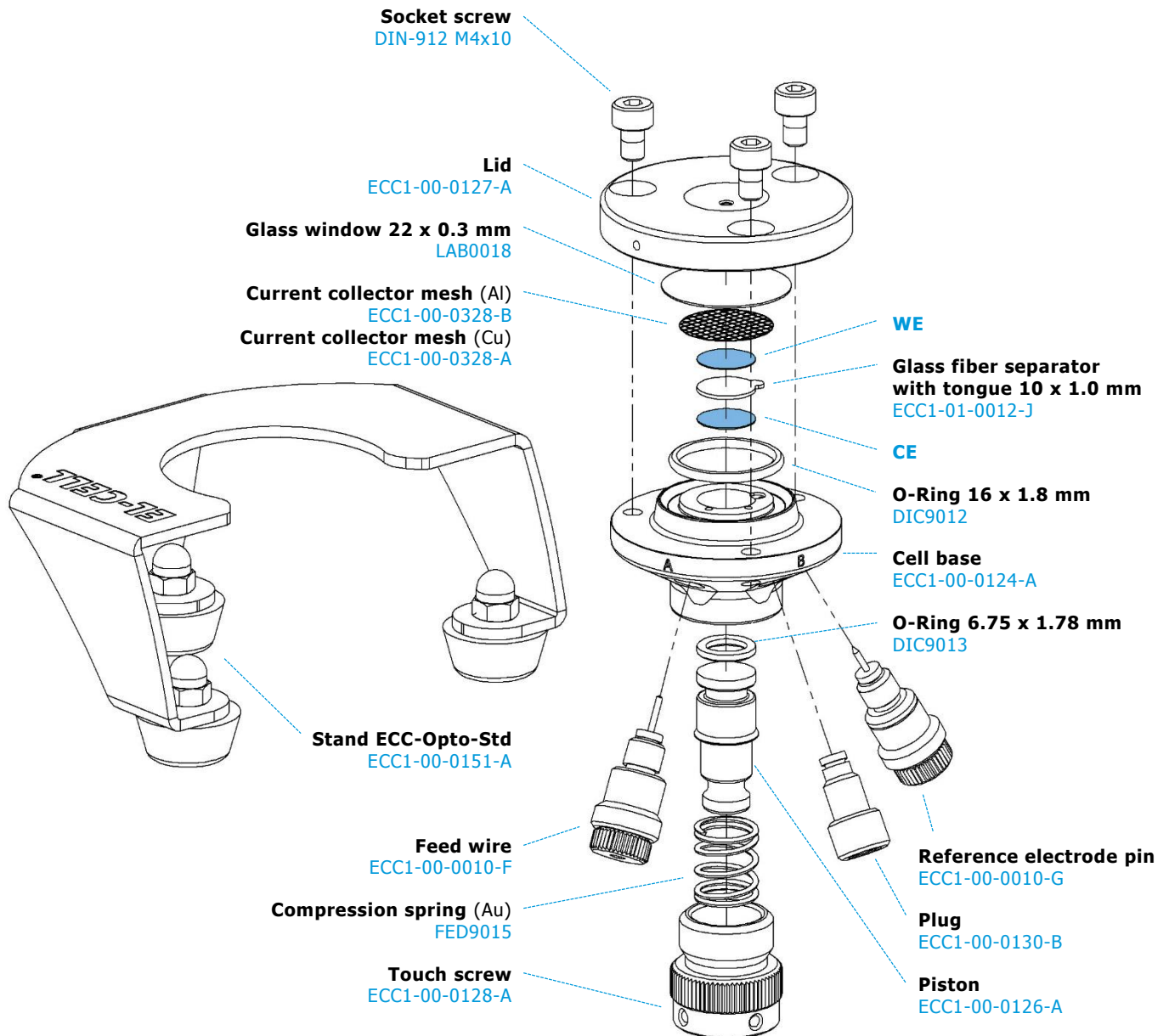



# 10 Spare Parts

## ECC-Opto-Std:

ECC1-00-0150-A

- Stand ECC-Opto-Std [ECC1-00-0151-A](#)
- ECC-Opto cell cable [ECE1-00-0075-A](#)
- Foot for stand [VOR9031](#)
- Socket screw (Lid) [DIN-912 M4x10](#)
- Lid [ECC1-00-0127-A](#)
- Cell base [ECC1-00-0124-A](#)
- Feed wire [ECC1-00-0010-F](#)
- Compression spring **10 N** (Au) standard, (5 pieces) [FED9015/V](#)  
Spring forces see page 12
- Compression spring **20 N** (Au) (5 pieces) [FED9020/V](#)  
Spring forces see page 12
- Compression spring **30 N** (Au) (5 pieces) [FED9021/V](#)  
Spring forces see page 12
- Touch screw [ECC1-00-0128-A](#)
- Reference electrode pin [ECC1-00-0010-G](#)
- Plug [ECC1-00-0130-B](#)
- Piston [ECC1-00-0126-A](#)

## Accessories Kit:

ECC1-00-0306-A

- Feed wire, assy [ECC1-00-0010-F](#)
- Filling tube with syringe (5 ml) for vacuum filling [ECC1-01-0001-A](#)
- Hex wrench 0.9 mm [WZG9005](#)
- Spherical hex screw driver 3 mm [WZG9002](#)

# 11 Consumables

## Accessories Kit:

ECC1-00-0306-A

- Glass window (5 pieces) [LAB0018/V](#)
- Glass fiber separator (5 pieces) [ECC1-01-0012-J/V](#)
- Current collector mesh, copper (5 pieces) [ECC1-00-0328-A/V](#)
- Current collector mesh, aluminium (5 pieces) [ECC1-00-0328-B/V](#)
- O-Ring 6.75 mm x 1.78 mm [DIC9013](#)
- O-Ring 16 mm x 1.8 mm [DIC9012](#)

## 12 Technical Support

Technical support for this product is exclusively provided by EL-CELL GmbH.

### **EL-CELL GmbH**

Tempowerkring 8

21079 Hamburg - Germany

**phone:** +49 (0)40 790 12 733

**fax:** +49 (0)40 790 12 736

**e-mail:** [info@el-cell.com](mailto:info@el-cell.com)

**web:** [www.el-cell.com](http://www.el-cell.com)

## 13 Warranty

For a period of one year from the date of shipment, EL-CELL GmbH (hereinafter Seller) warrants the goods to be free from defect in material and workmanship to the original purchaser. During the warranty period, Seller agrees to repair or replace defective and/or nonconforming goods or parts without charge for material or labor, or, at the Seller's option, demand return of the goods and tender repayment of the price. Buyer's exclusive remedy is repair or replacement of defective and nonconforming goods, or, at Seller's option, the repayment of the price.

Seller excludes and disclaims any liability for lost profits, personal injury, interruption of service, or for consequential incidental or special damages arising out of, resulting from, or relating in any manner to these goods.

This Limited Warranty does not cover defects, damage, or nonconformity resulting from abuse, misuse, neglect, lack of reasonable care, modification, or the attachment of improper devices to the goods. This Limited Warranty does not cover expendable items. This warranty is void when repairs are performed by a non-authorized person or service center. At Seller's option, repairs or replacements will be made on site or at the factory. If repairs or replacements are to be made at the factory, Buyer shall return the goods prepaid and bear all the risks of loss until delivered to the factory. If Seller returns the goods, they will be delivered prepaid and Seller will bear all risks of loss until delivery to Buyer. Buyer and Seller agree that this Limited Warranty shall be governed by and construed in accordance with the laws of Germany.

The warranties contained in this agreement are in lieu of all other warranties expressed or implied, including the warranties of merchantability and fitness for a particular purpose.

This Limited Warranty supersedes all prior proposals or representations oral or written and constitutes the entire understanding regarding the warranties made by Seller to Buyer. This Limited Warranty may not be expanded or modified except in writing signed by the parties hereto.