

Compact Xenon Light Source 100W LAX-C100

Heatless illumination with desired wavelengths



Features

- IR heat blocking by mirror module*
- Built-in filter holder*
- Adjustable light intensity
- Flexible illumination by light guide
- No need of optical axis alignment
- RS232C remote control

*Options

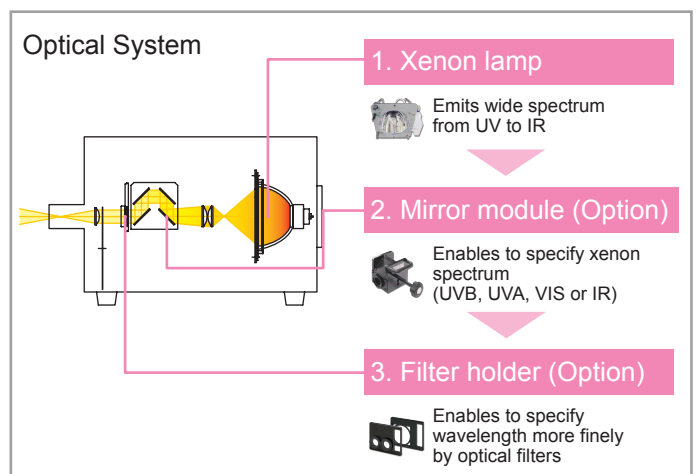
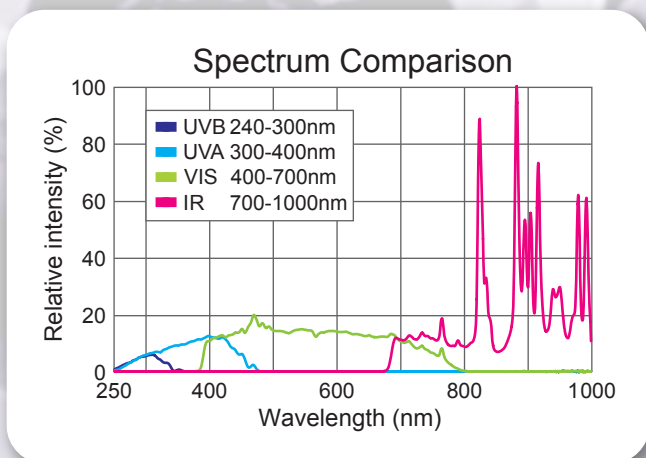

The mirror module blocks the heat and stray light

The LAX-C100 is the reasonable xenon light source with xenon 100W lamp. The proprietary mirror module blocks the heat and stray light, and only desired wavelength range is obtainable. The LAX-C100 can also emit monochromatic light by the bandpass filter.

*Mirror module, filter holder and optical filters are optional.



Usage Example

Monochromatic Light with Optical Filters

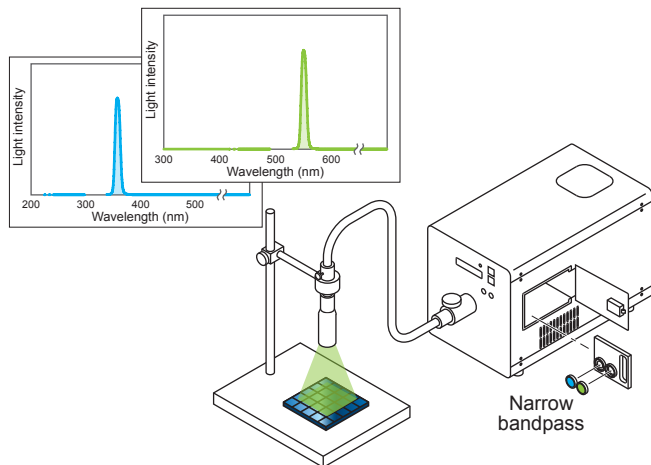

- Bright monochromatic light
- Instead of multiple wavelength laser
- Output beam is brighter than monochromator

UV Light Source

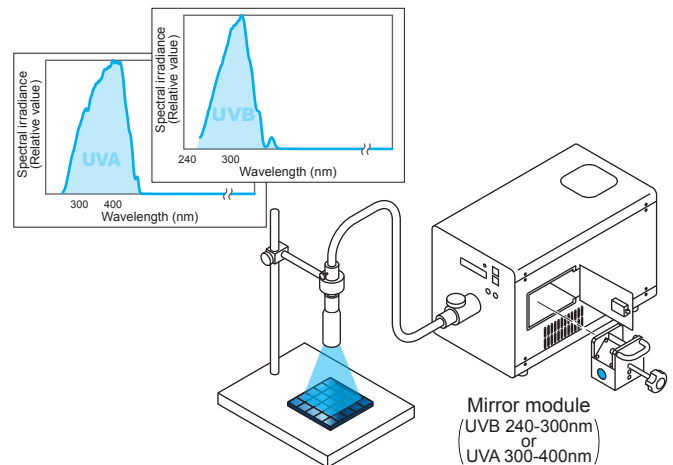

- Bright UV light
- It is also possible to obtain the desirable UV wavelength range with the combination of optical filters

Technical Data

Lamp Start-up Characteristics

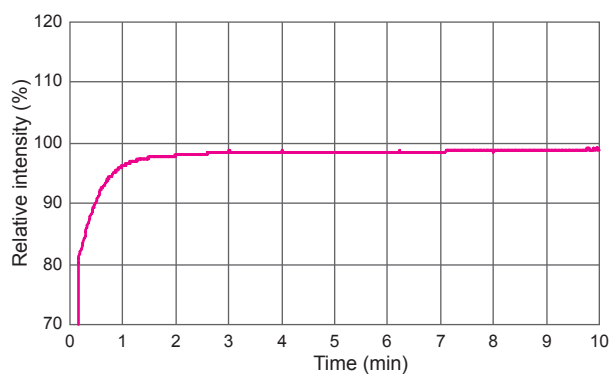

Lamp Fluctuation

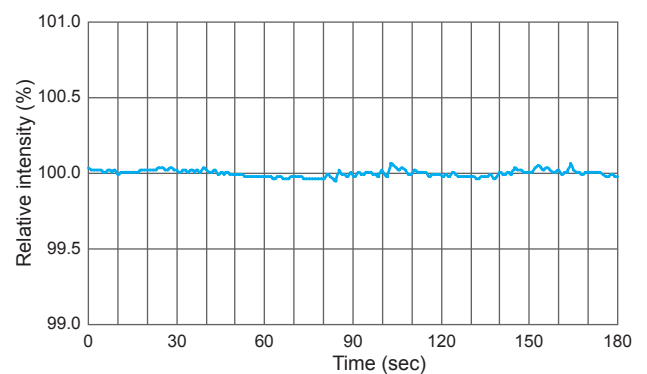

Features

Optical System

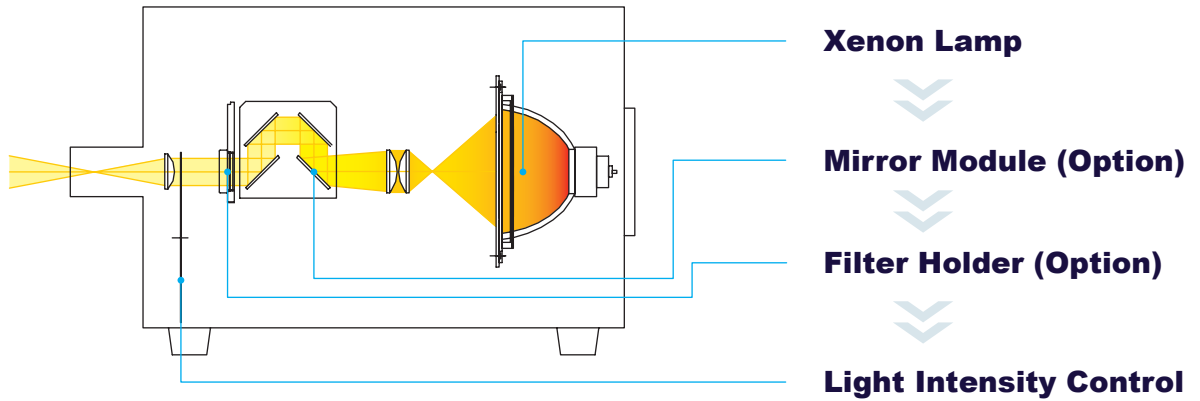

Xenon Arc Lamp



The 100W xenon arc lamp is mounted into the cartridge and it can achieve the efficient transition of xenon lamp energy. The lamp cartridge is easily replaced and alignment is not necessary.

Spectral Intensity of Xenon Lamp

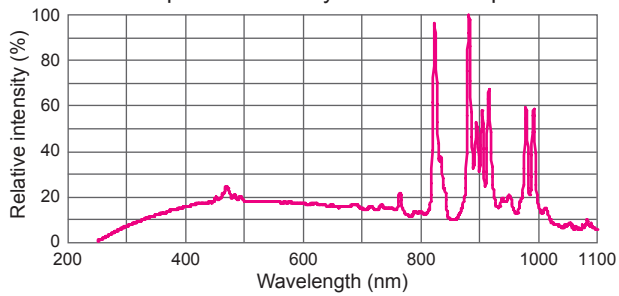

Mirror Module (Option)



This sophisticated optical unit consists of four cold mirrors to block unwanted energy from xenon lamp and only desired throughput is obtainable. The LAX-C100 offers 4 types of mirror module.

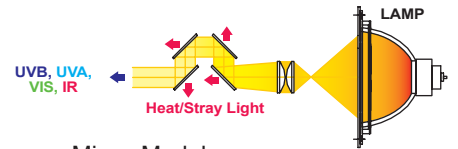

Mirror Module

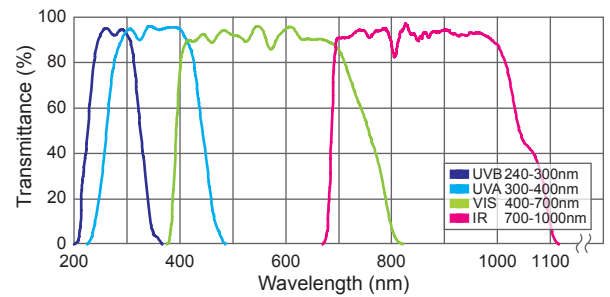

Filter Holder (Option)



There are 2 types of the filter holder.
 1. 25mm dia. x 2 pcs.
 2. 50mm dia. or 50 x 50mm x 1 pc.

Usage Example of 25mm dia. Holder

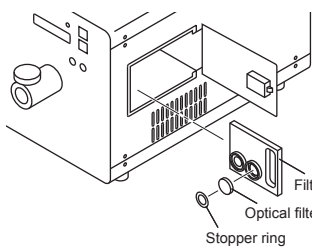

*25mm dia. holder and 50 x 50mm holder cannot be mounted together.

Light Intensity Control



Built-in plate enables a simple variable light control from 5 to 100 steps. It is useful for microscope or imaging application.

Panel Controls

User-friendly menu and comprehensive display for easy operation.



1. Turn On/Off the xenon lamp
2. Shutter function Open/Close
3. Light intensity adjustment

RS232C Remote Control

The LAX-C100 can be controlled remotely by using RS232C.

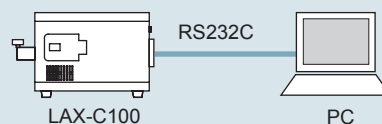

Options

Light Guide



The output light from the LAX-C100 is delivered to a desired direction by the light guide.
We also offer a multi-branch light guide for custom.

Spectral Performance

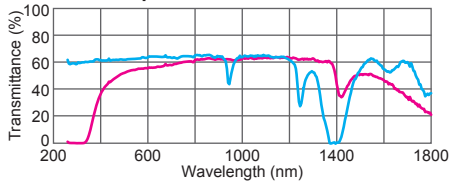

- Quartz Light Guide**
 - Length(L): 1m, 2m
 - Fiber bundle: 5mm dia.
 - Core: 200µm dia.
 - Numerical aperture: 0.22
- Hybrid Light Guide**
 - Length(L): 1m, 2m
 - Fiber bundle: 5mm dia.
 - Core: 50µm dia.
 - Numerical aperture: 0.57

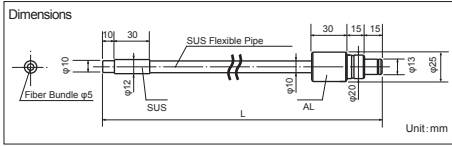

Collimator Lens



Each collimator lens is designed to provide the uniform illumination by using with the light guide.

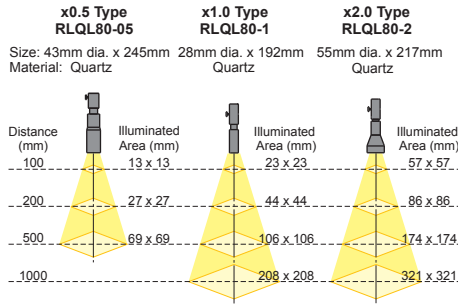

Narrow Bandpass Filter



We offer a wide variety of narrow bandpass filters for a monochromatic illumination.

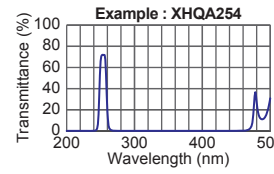

CWL tolerance: 254±2nm
FWHM tolerance: 10±2nm
Min. transmission: >60%
Size: 25mm dia.

Wavelength (nm)	Item #	Mirror Module
254	XHQA254 - XHQA290	UVB
290		
300	XHQA300 - XHQA390	UVA
390		
400	XHQA400 - XHQA450 XBPA460 - XBPA700	VIS
700		
710		
900	XBPA710 - XBPA900	IR

*Contact us for information about filters not listed above

Scope of Delivery

- LAX-C100 main unit
- Lamp cartridge
- AC cable (3m)
- RS232C cable (1.8m)
- Instruction manual

Obtainable Throughput Ranges

	Mirror Module	Spectral Output
LAX-C100	UVB	240-300nm
	UVA	300-400nm
	VIS	400-700nm
	IR	700-1000nm

General Specifications

- Model: LAX-C100
- Output wavelength: 240 - 1000nm
(It depends on the mirror module.)
- Circuit method: Switching power supply
- Input voltage: AC100V 50/60Hz (Input range: AC 90 - 132V)
AC200V 50/60Hz (Input range: AC198 - 264V)
*Select input voltage when placing an order.
- Apparent power: Less than 350VA (100V/50Hz)
Less than 440VA (240V/50Hz)
- Lamp type: Xenon lamp 100W
- Lamp voltage, current: 12.8 - 14V 7.2A (DC) *Representative value
- Lamp life: 500h (Average)
*When the light intensity has decreased by 50% from the initial value.
- Optical axis alignment: Cartridge type (Alignment-free)
- Cooling method: Forced air cooling
- Shutter: Pulsed motor drive
- Light intensity control: 100 - 5 (Steps) Continuously variable
- Controller: Built-in
- Remote control: RS232C
*The cable must be less than 3m.
- Safety mechanism: Xenon lamp problem, Rear door is open,
Lamp usage exceeds 500 hours, Cooling fan problem,
Temperature anomaly
- Recommended environment: Temperature 10 - 35 deg C
Humidity 20 - 80% *Avoid condensation
- Dimensions: 200(W) x 340(D) x 245(H)mm
- Weight: 8.2kg

Dimensions

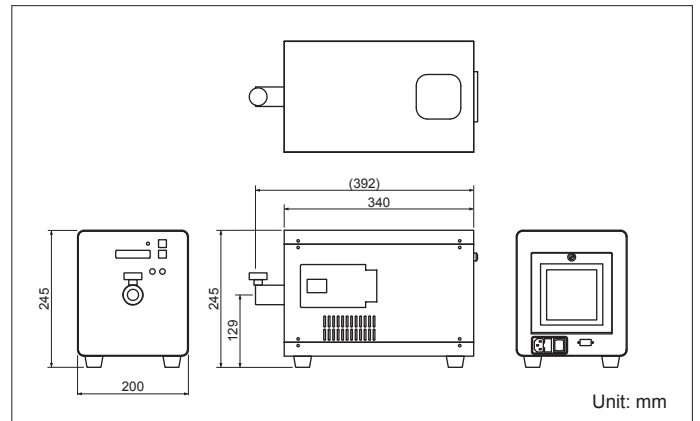

*Product specifications are subject to change without notice.