

TMC 超净间工作台 63-600

ClassOne™ Workstation for Cleanrooms

全不锈钢材质的 TMC ClassOne™ 工作台是一种高性能用于超净间的气浮振动隔离桌。隔振采用 Gimbal Piston 提供，在光学隔振平台、电子显微镜、精密平衡和扫描显微镜等应用方面提供了无与伦比的隔振性能。

TMC 超净间工作台 63-600 ClassOne 工作台在发货之前，在工厂里用无绒布经酒精擦拭，用塑料包裹双层后再发货。

TMC 超净间工作台 63-600 参数

隔离器固有频率	
高频输入	垂直方向=1.2Hz，水平方向=1.0Hz
低频输入	垂直方向=1.5-2.0Hz，水平方向=1.2-1.7Hz
隔离器效率 @5HZ	垂直方向=70-85% 水平方向=75-90%
隔离器效率 @10Hz	垂直方向=90-97% 水平方向=90-97%
推荐负载能力:	160Kg
整体材料:	用电解法抛光不锈钢框架，钝化或用电解法抛光的不锈钢平台
空压机要求	80psi 氮气或空气
船运重量	272kg

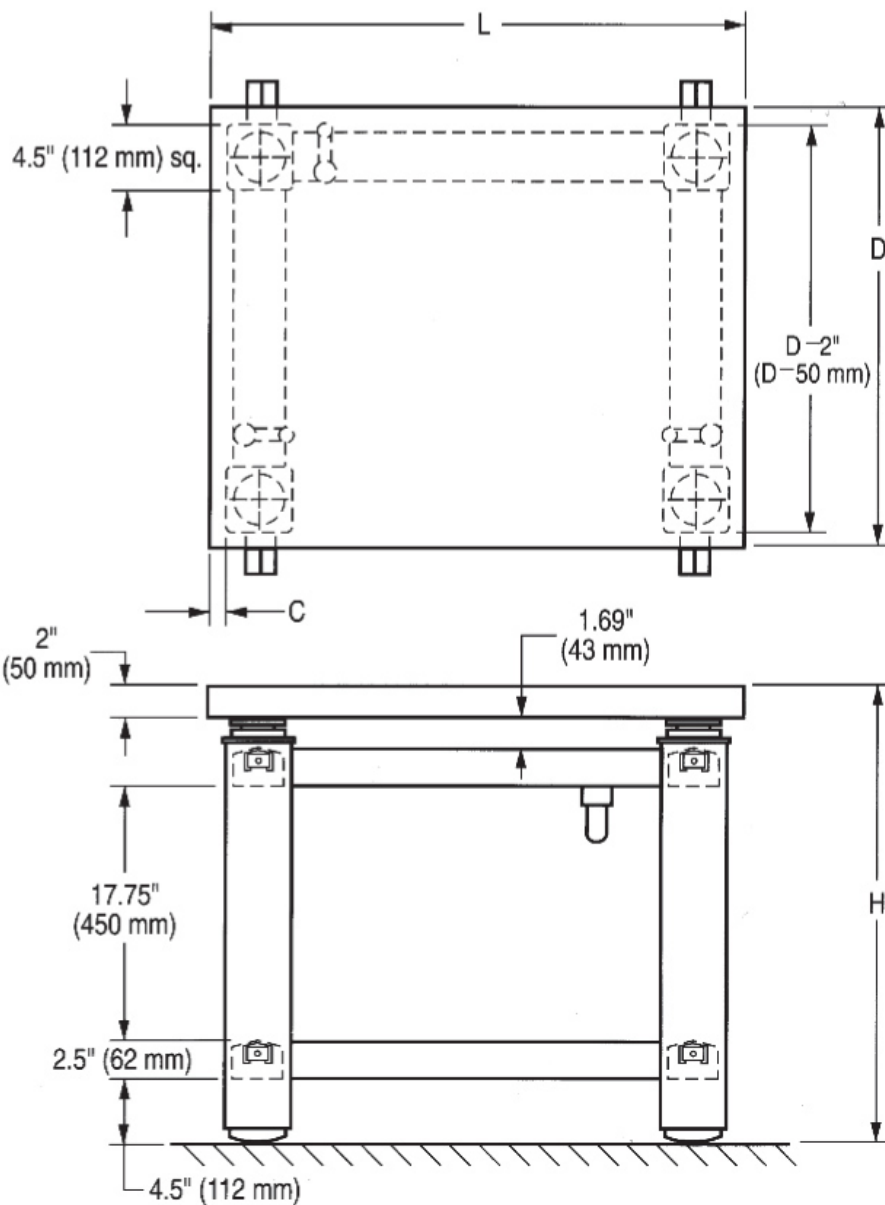

A front support bar is included as standard with all ClassOne workstations.

ClassOne workstations with Gimbal Piston Vibration Isolation

Table Size (DxL)	Passivated Stainless Steel Top	Electropolished Stainless Steel Top
750 x 875 mm 29.5 x 34.5 in.	63-631	63-635
750 x 1175 mm 29.5 x 46.3 in.	63-641	63-645
900 x 1175 mm 35.4 x 46.3 in.	63-661	63-665

900 x 1500 mm 35.4 x 59.0 in.	63-671	63-675
--	--------	--------

Accessories - All Table Sizes

Retractable Casters (set of four)	83-015-01
-----------------------------------	-----------

Accessories - Size Dependent

Table Size (DxL)	Sliding Shelf - 25 mm (10 in.) Pattern: 10 mm (0.4 in.) holes on 25 mm (1 in.) centers	Rear Support Bar & Mounting Clamps¹
750 x 875 mm 29.5 x 34.5 in.	81-312-06	81-302-05
750 x 1175 mm 29.5 x 46.3 in.	81-312-06	81-302-06
900 x 1175 mm 35.4 x 46.3 in.	81-312-07	81-302-06
900 x 1500 mm 35.4 x 59.0 in.	81-312-07	81-302-07

¹ Required when specifying Shelves