



MVP DC SERIES

Diaphragm pumps as backing pumps for HiPace turbopumps

MVP DC SERIES

Diaphragm pumps as backing pumps for HiPace turbopumps

Clean, dry vacuum

Diaphragm pumps function completely without any oil and do not generate any particles. As a result these pumps are ideally suited for applications in which a clean and dry vacuum is necessary. Another major benefit of diaphragm pumps is their long lifetime. At sensitive locations, diaphragm pumps not only perform reliably, but with a minimum of vibration and noise. The noise level is usually below 50 dB(A).

Low voltage 24 V DC

The diaphragm pumps of the MVP DC series are the ideal backing pumps for turbopumps due to the 24 V DC power supply on the HiPace turbopumps. The electronic DC motor allows adjustments to the rotational speed according to specific applications. With the automatic boost mode, the pump will start at full speed and lower the speed once a certain level of vacuum is reached to ensure high performance, long maintenance intervals, as well as low noise and vibrations. Thanks to its stand-by mode the pump achieves a particularly high energy efficiency.

Highly reliable

The 2-stage pumps are equipped with a magnetic gas ballast valve for increased process reliability and durability. Operating temperature ranges from 5 to 40 °C to cover a wide range of applications. With their easy maintenance and long service intervals of approx. 2 years, these pumps guarantee very low cost of ownership.

Customer benefits

- Clean and dry vacuum
- Less safety precautions due to low voltage 24 V DC
- Easy system integration for one complete vacuum solution
- Increased process durability and reliability
- Increased mobility due to low weight
- Low cost of ownership

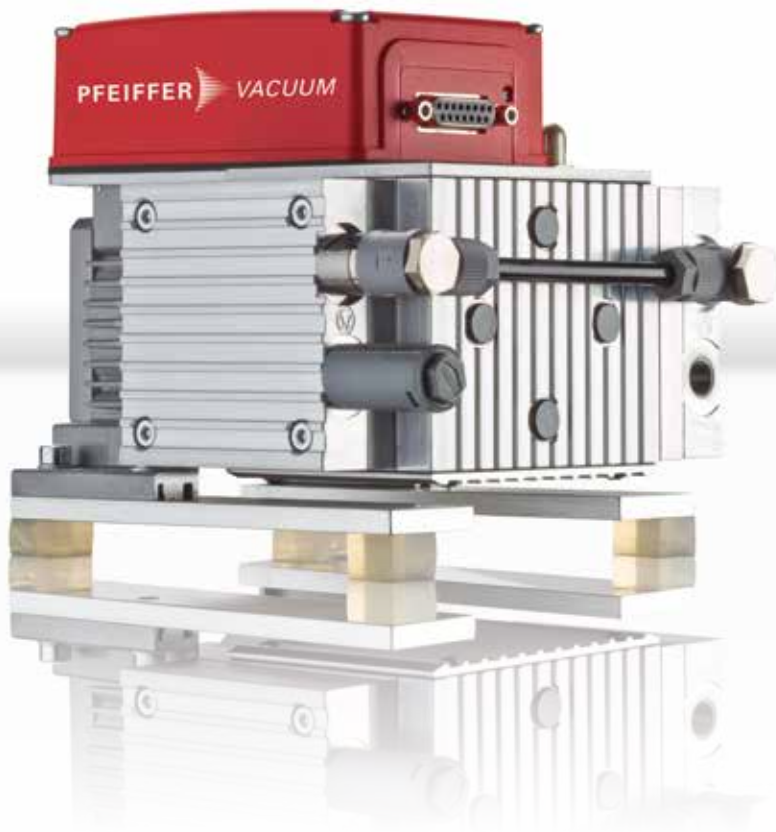

Applications

- Mass spectrometry
- Electron microscopy
- Residual gas analysis
- Surface analysis
- Leak detection
- Pumping stations

MVP DC SERIES

Pumping speed, dimensions

Pumping speed

MVP 010-3 DC

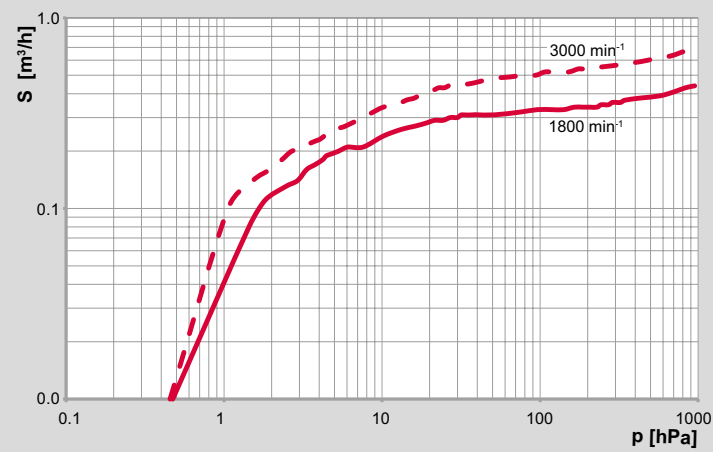

MVP 015-2 DC

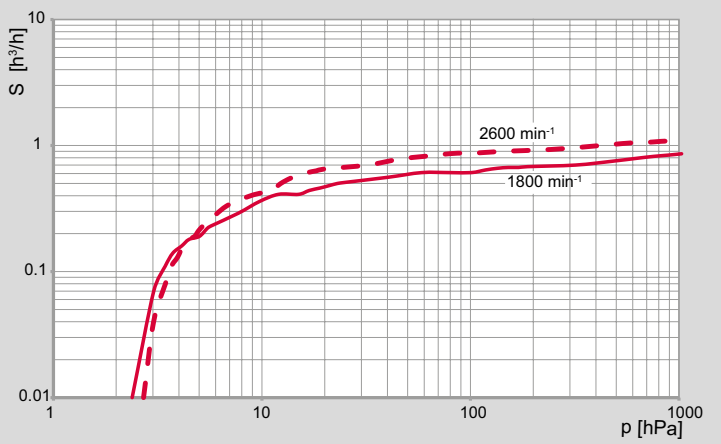

MVP 015-4 DC

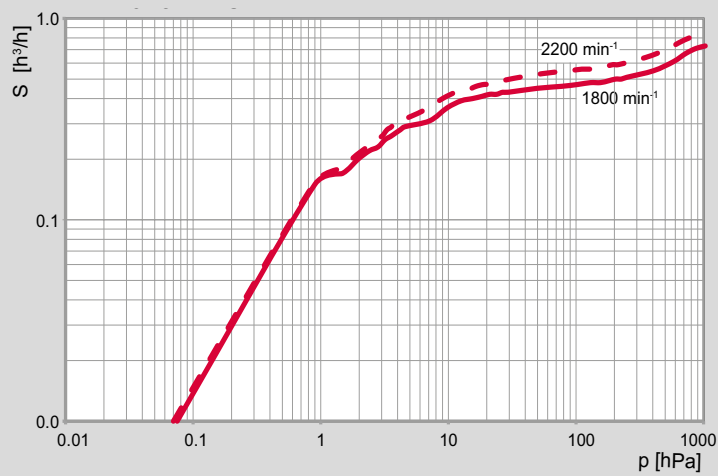

MVP 030-3 DC

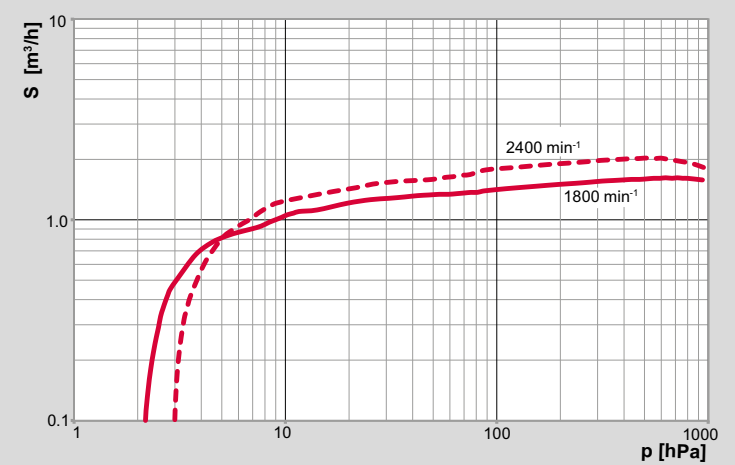

Dimensions

MVP 010-3 DC

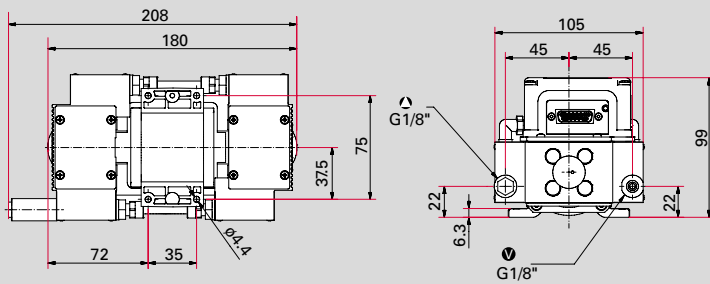

MVP 015-2 DC

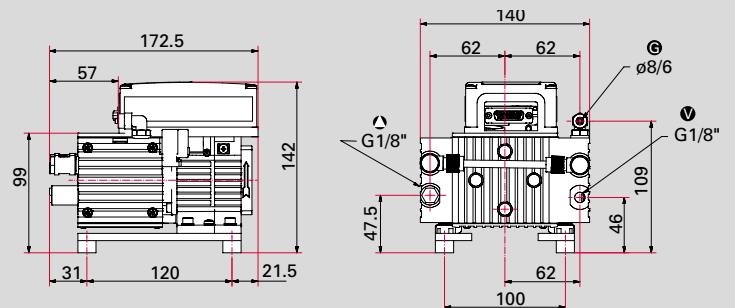

MVP 015-4 DC

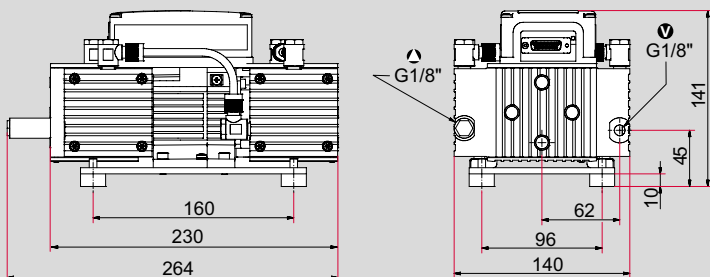

MVP 030-3 DC

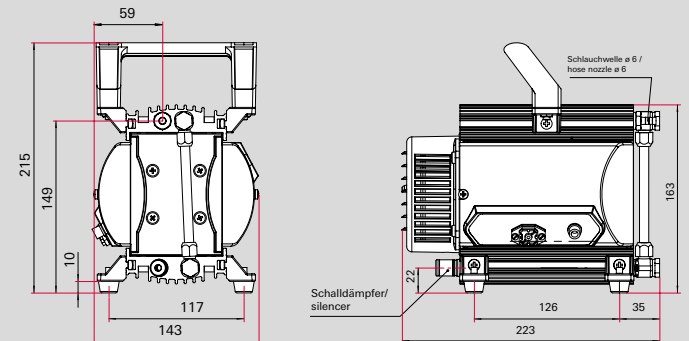

Dimensions in mm

MVP DC SERIES

Technical data, order numbers, accessories, spare parts

Technical data

	MVP 010-3 DC	MVP 015-2 DC	MVP 015-4 DC	MVP 030-3 DC
Flange (out)	G 1/8" with silencer	G 1/8" with silencer	G 1/8" with silencer	G 1/8" with silencer
Flange (in)	G 1/8"	G 1/8"	G 1/8"	G 1/8"
Exhaust pressure, max	1,100 hPa	1,100 hPa	1,100 hPa	1,100 hPa
Rotation speed	1,800 1/min	1,800 1/min	1,800 1/min	1,800 1/min
Rotation speed max.	3,000 1/min	2,600 1/min	2,200 1/min	2,400 1/min
Ultimate pressure with gas ballast	–	≤ 4 hPa	–	3 hPa
Ultimate pressure without gas ballast	1 hPa	≤ 3.5 hPa	≤ 0.5 hPa	2.5 hPa
Weight with motor	2.0 kg	2.7 kg	4.4 kg	4.3 kg
Cooling method, standard	Air	Air	Air	Air
Pumping speed, max.	0.6 m ³ /h	1.0 m ³ /h	0.75 m ³ /h	1.8 m ³ /h
Protection category	IP 20	IP 20	IP 20	IP 40
Current consumption	2.5 A	4.6 A	5.8 A	7 A
Ambient temperature	5–40 °C	5–40 °C	5–40 °C	12–40 °C
Supply: Voltage	24 (± 10%) V DC	24 (± 10%) V DC	24 (± 10%) V DC	24 (± 10%) V DC
Emission sound pressure level without gas ballast	≤ 50 dB (A)	≤ 50 dB (A)	≤ 50 dB (A)	≤ 48 dB (A)

Order numbers

	MVP 010-3 DC	MVP 015-2 DC	MVP 015-4 DC	MVP 030-3 DC
Diaphragm pump	PK T05 072	PK T05 150	PK T05 068	PK T01 500

Easy installation

System set-up is very easy and cost-efficient due to the unified communication via 15-pin D-sub. Just connect the MVP with a HiPace turbopump, DCU controller and TPS power supply and you have a running system. Their low weight and compact size make the pumps of the MVP DC series ideal for integration in increasingly small analytical systems and turbopumping stations as well as for mobile applications.

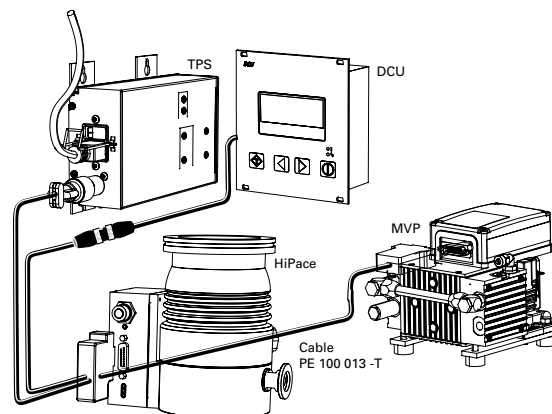

Accessories

	MVP 010-3 DC MVP 015-2 DC	MVP 030-3 DC MVP 015-4 DC
Power supply		
TPS 110, mains pack for wall/standard rail fitting	PM 061 340 -T	
TPS 180, mains pack for wall/standard rail fitting		PM 061 341 -T
TPS 111, mains pack 19" rack module 3HU	PM 061 344 -T	
TPS 181, mains pack 19" rack module 3HU		PM 061 345 -T
Power supplies and control displays		
DCU 110, Display Control Unit incl. power supply	PM C01 820	
DCU 180, Display Control Unit incl. power supply		PM C01 821
DCU 002, Display Control Unit		PM 061 348 -T
HPU 001, Handheld Programming Unit		PM 051 510 -T
Cables		
Mains cable 115 / 230 V without plug, with IEC 320/C13 socket (straight), 3 m		P 4564 309 ZH
Mains cable 230 V AC, CEE 7/7 to C13, 3 m		P 4564 309 ZA
Mains cable 115 V AC, NEMA 5-15 to C13, 3 m		P 4564 309 ZE
Connection cable for HiPace with TC 110/120		PM 061 543 -T
Connecting cable MVP-TC-TPS (size 3 m)		PE 100 013 -T
Connection cable with RS-485 interface for TC 110/120 to power supply		PM 061 350 -T
USB converter to RS-485 interface		PM 061 207 -T
Y-Connector M12 to RS-485		P 4723 010
Interface cable, M12 m straight/M12 m straight, 3 m		PM 061 283 -T
Flange and hose connection		
Screw-in flange DN 16 ISO-KF / G 1/8" incl. seal		PK 050 108 -T
Push-in fitting G 1/8 – 8/6		P 4131 029 G
Hose DN 6; (ø 8/6) Polyurethane		P 0991 939
Hose connection DN 6 x 400 mm for MVP and HiPace turbopumps		P 0920 739 E
Hose connection DN 6 x 1000 mm for MVP and HiPace turbopumps		P 0920 817 E

Spare parts

	Order numbers
Set of spare parts MVP 010-3 DC	PU E22 011 -T
Set of spare parts MVP 015-2 DC	PU E22 001 -T
Set of spare parts MVP 015-4 DC	PU E22 009 -T
Set of spare parts MVP 030-3 DC	PU E22 003 -T
Silencer G 1/8"	P 0920 567 E

VACUUM SOLUTIONS FROM A SINGLE SOURCE

Pfeiffer Vacuum stands for innovative and custom vacuum solutions worldwide, technological perfection, competent advice and reliable service.

COMPLETE RANGE OF PRODUCTS

From a single component to complex systems:

We are the only supplier of vacuum technology that provides a complete product portfolio.

COMPETENCE IN THEORY AND PRACTICE

Benefit from our know-how and our portfolio of training opportunities!

We support you with your plant layout and provide first-class on-site service worldwide.

Are you looking for a
perfect vacuum solution?
Please contact us:

Pfeiffer Vacuum GmbH
Headquarters · Germany
T +49 6441 802-0

www.pfeiffer-vacuum.com