

AquaLab Pre

Water Activity Meter

Operator's Manual



Decagon Devices, Inc.

Version: February 29, 2016 — 10:00:27

Decagon Devices, Inc.
2365 NE Hopkins Court
Pullman WA 99163

Phone: 509-332-5601

Fax: 509-332-5158

Website: www.aqualab.com

Email: support@aqualab.com or sales@aqualab.com

Trademarks

AquaLab is a registered trademark of Decagon Devices, Inc.

©2016 Decagon Devices, Inc.

Contents

1	Introduction	1
1.1	Customer Support	1
1.2	About This Manual	1
1.3	Warranty	2
1.4	Seller's Liability	2
2	About AquaLab Pre	3
2.1	Pre Instrument Specifications	3
2.2	AquaLab and Water Activity	4
2.3	How AquaLab Pre Works	4
2.3.1	Dew Point Block	4
2.3.2	Volatile Block	5
2.4	AquaLab and Temperature	5
3	Water Activity Theory	7
3.1	Moisture Content	7
3.2	Water Activity	7
3.3	Water Potential	9
3.4	Sorption Isotherms	11
4	Getting Started	13
4.1	Components of your AquaLab Pre	13
4.2	Choosing a Location	13
4.3	Features	14
4.4	Preparing AquaLab for Operation	15
5	The Menus	16
5.1	The Measurement Screen	16
5.2	Changing Languages	16
5.3	Normal Sampling Mode	17
5.4	Continuous Mode	17
5.5	Temperature Equilibration Screen	18
5.6	System Configuration	19
5.6.1	Completion Notification	19
6	Cleaning and Maintenance	22
6.1	Cleaning the Block and Sensors	23
6.1.1	Accessing the Block	23

6.2	Cleaning Procedures	24
6.3	Checking Calibration	26
7	Verification and Calibration	28
7.1	Water Activity Verification	28
7.2	Calibration Standards	28
7.3	Calibration	29
7.3.1	Adjusting for Linear Offset	31
8	Sample Preparation	34
8.1	Preparing the Sample	34
8.2	Samples Needing Special Preparation	35
8.3	Low Water Activity	37
9	Taking a Reading	39
9.1	Measurement Steps	39
9.2	How AquaLab takes Readings	40
9.3	Cautions	40
10	Computer Interface	42
10.1	AquaLink 4 Software	42
10.2	Using a Communication Program	43
11	Troubleshooting	45
11.1	Component Performance Screen	50
12	Support and Repair	52
12.1	Repair Costs	53
12.2	Loaner Service	53
13	Further Reading	54
13.1	Water Activity Theory & Measurement	54
14	Appendix A	76
14.1	Preparing Salt Solution	76
15	Appendix B	78
16	Declaration of Conformity	79
17	Certificate of Traceability	80

1 Introduction

Welcome to the AquaLab Pre Water Activity Meter. AquaLab Pre is a quick, accurate, and reliable instrument for measuring water activity (a_w). Whether you are doing research or working on the production line, AquaLab will suit your needs. It is easy to use and provides accurate and timely results. We hope you find this manual informative and helpful in understanding how to maximize the capabilities of your AquaLab Pre.

1.1 Customer Support

If you ever need assistance with your AquaLab Pre, have any questions or feedback, there are several ways to contact us. Decagon has Customer Service Representatives available to speak with you Monday thru Friday, between 7am and 5pm Pacific time.

Note: If you purchased your AquaLab Pre through a distributor, please contact them for assistance.

Email:

support@aqualab.com or **sales@aqualab.com**

Phone:

1-509-332-5601

Fax:

1-509-332-5158

If contacting us by email or fax, please include as part of your message your instrument serial number, your name, address, phone, fax number, and a description of your problem or question.

1.2 About This Manual

This manual includes instructions for setting up your AquaLab Pre, verifying the calibration of the instrument, preparing samples, and

maintaining and caring for your instrument. Please read these instructions before operating your instrument to ensure that the instrument performs to its full potential.

1.3 Warranty

AquaLab Pre has a 30-day satisfaction guarantee and a one-year warranty on parts and labor. Your warranty is automatically validated upon receipt of the instrument. We will contact you within the first 90 days of your purchase to see how your AquaLab works.

1.4 Seller's Liability

Seller warrants new equipment of its own manufacture against defective workmanship and materials for a period of one year from the date of receipt of equipment.

Note: We do not consider the results of ordinary wear and tear, neglect, misuse, accident and excessive deterioration due to corrosion from any cause as defects.

The Seller's liability for defective parts shall in no event exceed the furnishing of replacement parts Freight On Board the factory where originally manufactured. Material and equipment covered hereby which is not manufactured by Seller shall be covered only by the warranty of its manufacturer. Seller shall not be liable to Buyer for loss, damage or injuries to persons (including death), or to property or things of whatsoever kind (including, but not without limitation, loss of anticipated profits), occasioned by or arising out of the installation, operation, use, misuse, nonuse, repair, or replacement of said material and equipment, or out of the use of any method or process for which the same may be employed. The use of this equipment constitutes Buyer's acceptance of the terms set forth in this warranty. There are no understandings, representations, or warranties of any kind, express, implied, statutory or otherwise (including, but without limitation, the implied warranties of merchantability and fitness for a particular purpose), not expressly set forth herein.

2 About AquaLab Pre

AquaLab Pre is a fast and accurate instrument for measuring water activity (a_w), giving readings in five minutes or less. Its readings are reliable providing $\pm 0.01 a_w$ accuracy. The instrument is easy to clean and checking calibration is simple.

2.1 Pre Instrument Specifications

Water Activity Range: Dew point block – 0.05 to 1.00; Volatile block – 0.05 to 0.95 a_w

Water Activity Accuracy: Dew point block – ± 0.01 ; Volatile block – ± 0.015

Water Activity Resolution: 0.001

Read Time¹: ≤ 5 min.

Sample Temperature Control: 25 °C

Sample Temperature Accuracy²: ± 0.2 °C

Sample Temperature Resolution: 0.1 °C

Sample Dish Capacity: 7.5 ml Recommended (15 ml Full)

Operating Environment: 4 to 50 °C and 0 to 90% Relative Humidity (non-condensing)

Case Dimensions: 24.1 x 22.9 x 8.9 cm

Weight: 3.2 Kg

Case Material: Powder Painted Aluminum

Display: 20 x 2 alphanumeric backlit LCD

Data Communications: RS232A compatible, 8-data bit ASCII code, 9600 baud, no parity, 1 stop bit

¹On samples with no significant impedance to vapor loss.

²AquaLab is calibrated to a NIST traceable temperature standard.

Power: 110 VAC to 220 VAC, 50/60 Hz, consumes less than 0.4 amps

Warranty: 1 year parts and labor

2.2 AquaLab and Water Activity

Water activity (a_w) is a measurement of the energy status of the water in a system. It indicates how tightly water is “bound,” structurally or chemically, within a substance. Water activity is the relative humidity of air in equilibrium with a sample in a sealed measurement chamber. The concept of water activity is of particular importance in determining product quality and safety. Water activity influences color, odor, flavor, texture and shelf-life of many products. It predicts safety and stability with respect to microbial growth, chemical and biochemical reaction rates, and physical properties. For a more detailed description of water activity as it pertains to products, please refer to Section 3: “Water Activity Theory.”

2.3 How AquaLab Pre Works

Your AquaLab Pre comes with either a dew point block to measure the water activity of non-volatile samples or a volatile block to measure the water activity of volatile sample.

2.3.1 Dew Point Block

If your instrument uses the chilled-mirror dew point technique, the sample equilibrates with the headspace of a sealed chamber that contains a mirror and a means of detecting condensation on the mirror. At equilibrium, the relative humidity of the air in the chamber is the same as the water activity of the sample. In the AquaLab Pre, the mirror temperature is precisely controlled by a thermoelectric (Peltier) cooler. Detection of the exact point at which condensation first appears on the mirror is observed with a photoelectric cell. A beam of light is directed onto the mirror and reflected into a photodetector cell. The photodetector senses the change in reflectance

when condensation occurs on the mirror. A thermocouple attached to the mirror then records the temperature at which condensation occurs. AquaLab then signals you by flashing a green LED and/or beeping. The AquaLab Pre then displays the final water activity and temperature of the sample.

In addition to the technique described above, AquaLab uses an internal fan that circulates the air within the sample chamber to reduce equilibrium time. Since both dew point and sample surface temperatures are simultaneously measured, the need for complete thermal equilibrium is eliminated, which reduces measurement times to less than five minutes.

2.3.2 Volatile Block

If you are measuring samples with volatiles such as propylene glycol or ethanol, we recommend that you purchase a volatile block (uses a capacitance sensor) for your AquaLab Pre. Samples with a high amount of volatiles condense on the mirror during the reading process, but do not evaporate from the mirror as water does. As a result the reading on samples with volatiles may not be accurate with the dew point technique.

Not all volatiles react this way, but it is important to note that some volatiles can affect the performance of your instrument. The extent of the effect is both concentration and matrix-dependent; thus, just because a product contains some ethanol or propylene glycol does not necessarily mean the readings will be erroneous. Therefore, if your sample contains propylene glycol or a high concentration of other volatiles, it is still possible to make accurate readings. Refer to the section titled “Volatile Samples” or contact Decagon for more details.

2.4 AquaLab and Temperature

The AquaLab Pre controls temperature to 25 °C, making it ideal for the measurement of samples at room temperature. However, samples that are not at room temperature during the read cycle equilibrates

to the temperature of AquaLab before the water activity is displayed. Large temperature differences will cause longer reading times, since a complete and accurate reading will not be made until the sample and the instrument are within two degrees of each other. To better help you control the temperature difference between your sample and the instrument, you can access a sample equilibration screen at the main menu that shows the difference in temperature between the sample and block chamber. (See Section 4.) If tests need to be conducted at temperatures other than 25 °C, the temperature control feature can be turned off and the instrument can run at ambient temperatures.

3 Water Activity Theory

Water is a major component of foods, pharmaceuticals, and cosmetics. Water influences the texture, appearance, taste and spoilage of these products. There are two basic types of water analysis: moisture content and water activity.

3.1 Moisture Content

The meaning of the term moisture content is familiar to most people. It implies a quantitative analysis to determine the total amount of water present in a sample. There are two primary methods for determining moisture content: loss on drying and Karl Fisher titration, but you can also use secondary methods such as infrared and NMR. Moisture content determination is essential in meeting product nutritional labeling regulations, specifying recipes and monitoring processes. However, moisture content alone is not a reliable indicator for predicting microbial responses and chemical reactions in materials. The limitations of moisture content measurement are attributed to differences in the intensity with which water associates with other components.

3.2 Water Activity

Water activity is a measure of the energy status of the water in a system, and thus is a far better indicator of perishability than water content. Figure 1 shows how the relative activity of microorganisms, lipids and enzymes relate to water activity. While other factors, such as nutrient availability and temperature, can affect the relationships, water activity is the best single measure of how water affects these processes. Researchers measure the water activity of a system by equilibrating the liquid phase water in the sample with the vapor phase water in the headspace and measuring the relative humidity of the head-space. In the AquaLab, you place a sample in a sample cup that seals inside the sample chamber. Inside the sample chamber is a fan, a dew point sensor, a temperature sensor, and an infrared thermometer. The dew point sensor measures the dew point

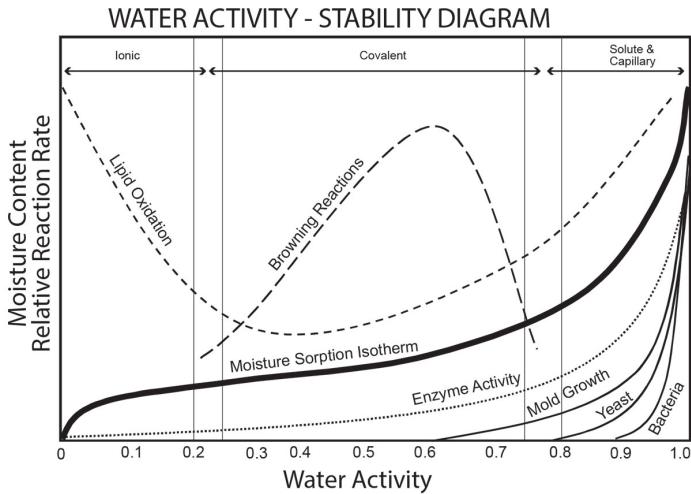

Figure 1: Water Activity Diagram adapted from Labuza

temperature of the air in the chamber, and the infrared thermometer measures the sample temperature. From these measurements, the relative humidity of the head-space is computed as the ratio of dew point temperature saturation vapor pressure to saturation vapor pressure at the sample temperature. When the water activity of the sample and the relative humidity of the air are in equilibrium, the measurement of the head-space humidity gives the water activity of the sample. The purpose of the fan is to speed equilibrium and to control the boundary layer conductance of the dew point sensor.

In addition to equilibrium between the liquid phase water in the sample and the vapor phase, the internal equilibrium of the sample is important. If a system is not at internal equilibrium, one might measure a steady vapor pressure (over the period of measurement) which is not the true water activity of the system. An example of this might be a baked good or a multi-component food. Initially out of the oven, a baked good is not at internal equilibrium; the outer surface is at a lower water activity than the center of the baked good. One must wait a period of time in order for the water to migrate and the system to come to internal equilibrium. It is important to remember the restriction of the definition of water activity to equilibrium.

Temperature Effects

Temperature plays a critical role in water activity determination. Most critical is the measurement of the difference between sample and dew point temperature. If this temperature difference were in error by 1 °C, an error of up to 0.06 a_w could result. In order for water activity measurements to be accurate to 0.001, temperature difference measurements need to be accurate to 0.017 °C. The AquaLab infrared thermometer measures the difference in temperature between the sample and the block. It is carefully calibrated to minimize temperature errors, but achieving 0.017 °C accuracy is difficult when temperature differences are large. Best accuracy is therefore obtained when the sample is near chamber temperature.

Another effect of temperature on water activity occurs when samples are near saturation. A sample that is close to 1.0 a_w and is only slightly warmer than the sensor block condenses water within the block. This causes errors in the measurement, and in subsequent measurements until the condensation disappears. A sample at 0.75 a_w needs to be approximately 4 °C above the chamber temperature to cause condensation. The AquaLab warns the user if a sample is more than 4 °C above the chamber temperature, but for high water activity samples the operator needs to be aware that condensation can occur if a sample that is warmer than the block is put in the AquaLab.

3.3 Water Potential

Some additional information may be useful for understanding what water activity is and why it is such a useful measure of moisture status in products. Water activity is closely related to a thermodynamic property called the water potential, or chemical potential (μ) of water, which is the change in Gibbs free energy (ΔG) when water concentration changes. Equilibrium occurs in a system when (μ) is the same everywhere in the system. Equilibrium between the liquid and the vapor phases implies that (μ) is the same in both phases. It is this fact that allows us to measure the water potential of the va-

por phase and use that to determine the water potential of the liquid phase. Gradients in (μ) are driving forces for moisture movement. Thus, in an isothermal system, water tends to move from regions of high water potential (high a_w) to regions of low water potential (low a_w). Water content is not a driving force for water movement, and therefore can not be used to predict the direction of water movement, except in homogeneous materials.

Factors In Determining Water Activity

The water activity of the water in a system is influenced by factors that effect the binding of water. They include osmotic, matric, and pressure effects. Typically water activity is measured at atmospheric pressure, so only the osmotic and matric effects are important.

Osmotic Effects: Osmotic effects are well known from biology and physical chemistry. Water is diluted when a solute is added. If this diluted water is separated from pure water by a semi-permeable membrane, water tends to move from the pure water side through the membrane to the side with the added solute. If sufficient pressure is applied to the solute-water mixture to just stop the flow, this pressure is a measure of the osmotic potential of the solution. Addition of one mole of an ideal solute to a kilogram of water produces an osmotic pressure of 22.4 atm. This lowers the water activity of the solution from 1.0 to 0.98 a_w . For a given amount of solute, increasing the water content of the systems dilutes the solute, decreasing the osmotic pressure, and increasing the water activity. Since microbial cells are high concentrations of solute surrounded by semi-permeable membranes, the osmotic effect on the free energy of the water is important for determining microbial water relations and therefore their activity.

Matric Effects: The sample matrix affects water activity by physically binding water within its structure through adhesive and cohesive forces that hold water in pores and capillaries, and to particle surfaces. If cellulose or protein were added to water, the energy status of the water would be reduced. Work would need to be done to extract the water from this matrix. This reduction in energy status

of the water is not osmotic, because the cellulose or protein concentrations are far too low to produce any significant dilution of water. The reduction in energy is the result of direct physical binding of water to the cellulose or protein matrix by hydrogen bonding and van der Waal forces. At higher water activity levels, capillary forces and surface tension can also play a role.

3.4 Sorption Isotherms

Relating Water Activity to Water Content

Changes in water content affect both the osmotic and matric binding of water in a product. Thus a relationship exists between the water activity and water content of a product. This relationship is called the sorption isotherm, and is unique for each product. Besides being unique to each product, the isotherm changes depending on whether it was obtained by drying or wetting the sample. These factors need to be kept in mind if one tries to use water content to infer the stability or safety of a product. Typically, large safety margins are built into water content specifications to allow for these uncertainties.

While the sorption isotherm is often used to infer water activity from water content, one could easily go the other direction and use the water activity to infer the water content. This is particularly attractive because water activity is much more quickly measured than water content. This method gives particularly good precision in the center of the isotherm. In order to infer water content from water activity, one needs an isotherm for the particular product. Decagon sells an Isotherm Generator called the AquaLab Vapor Sorption Analyzer (VSA) or you can also have Decagon run the isotherm for a fee.

For example, if you were using the AquaLab to monitor the water content of dried potato flakes, you would measure the water activity and water content of potato flakes dried to varying degrees using the standard drying process for those flakes. You could then use that data to construct an isotherm and infer the water content using the measured water activity of samples and that isotherm. Decagon has an upgrade available to Series 4TE users that would allow you to

determine moisture content and water activity simultaneously. This instrument is called the Series 4TE DUO.

We cannot overemphasize the importance of the concept of water activity for foods, pharmaceuticals, and cosmetics. Water activity is a measure of the energy status of the water in a system. More importantly, the usefulness of water activity in relation to microbial growth, chemical reactivity, and stability over water content has been shown.

4 Getting Started

4.1 Components of your AquaLab Pre

Your AquaLab should have shipped with the following items.

- AquaLab Pre water activity meter
- Power cord
- RS-232 to USB interface cable
- 50 disposable sample cups
- Calibration Certificate
- SDS Booklet
- Three spare filters for capacitance sensor

Note: The three spare filters are only included if you purchased the volatiles block.

- Operator's Manual
- Quick Start Guide
- Cleaning Kit
- Shipping Checklist
- Two vials each of the following verification solutions:

1.00 a_w USP Purified Water

0.984 a_w 0.50 mol/kg KCl

0.920 a_w 2.33 mol/kg NaCl

0.760 a_w 6.00 mol/kg NaCl

0.500 a_w 8.57 mol/kg LiCl

0.250 a_w 13.41 mol/kg LiCl

4.2 Choosing a Location

To ensure that your AquaLab Pre operates correctly and consistently, place it on a level surface. This reduces the chance that sample ma-

terial will spill and contaminate the sample chamber. Also select a location where the temperature remains fairly stable to avoid temperature changes that can affect accuracy. This location should be well away from air conditioner and heater vents, open windows, etc. Place the AquaLab in a location where cleanliness can be maintained to prevent contamination of the sample chamber.

4.3 Features

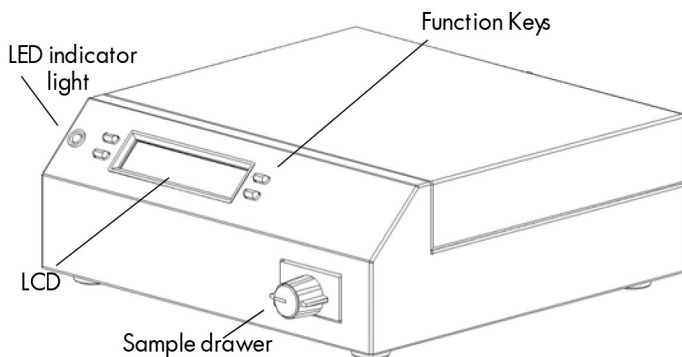

Figure 2: Front View of AquaLab Pre

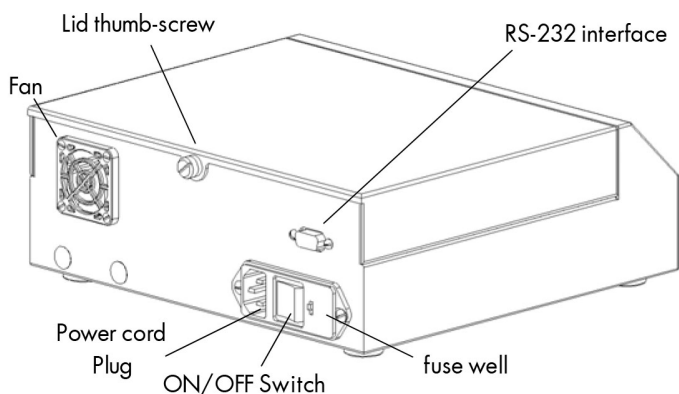
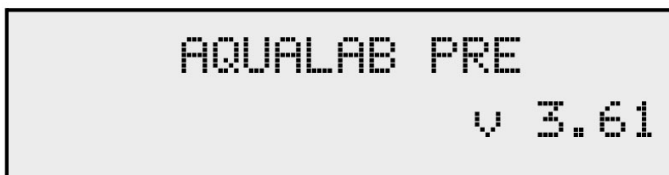

Figure 3: Back View of AquaLab Pre

4.4 Preparing AquaLab for Operation

After finding a good location for your AquaLab, plug the power cord into the back of the unit. Before turning it on, turn the knob to the “Open or Load” position, pull open the sample drawer and remove the empty disposable sample cup. This empty cup is placed in the drawer to protect it during shipment. Turn the instrument on (see features diagram). The Title screen will appear on the LCD.



NOTE: The “v 3.61” shown in the above illustration is an example showing the version of operating code used in the instrument. We periodically update the code and add new features, so if your AquaLab shows a version number higher than this, do not be alarmed.

Following the Title screen the AquaLab Pre will automatically shift to the Measurement screen shown below with a displayed water activity (a_w) on the top left portion of the screen, and the sample temperature in the lower right.

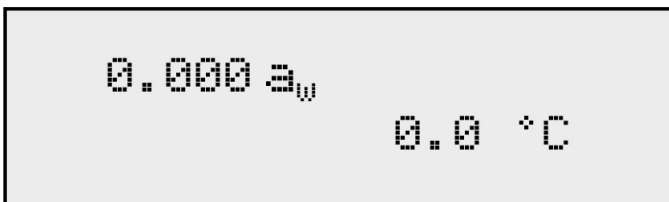

In order to provide the most accurate readings, allow your AquaLab to warm-up for at least 15 minutes after turning it on. This allows the air inside the AquaLab to equilibrate to the temperature of its surroundings.

5 The Menus

5.1 The Measurement Screen



Each time you turn on your AquaLab, the Measurement screen above will appear and the water activity and sample temperature will display on the screen. On each side of the LCD there are two buttons. Each button performs a different function. Figure 4 provides a description of the modes and options you may use, and the buttons used to set them.

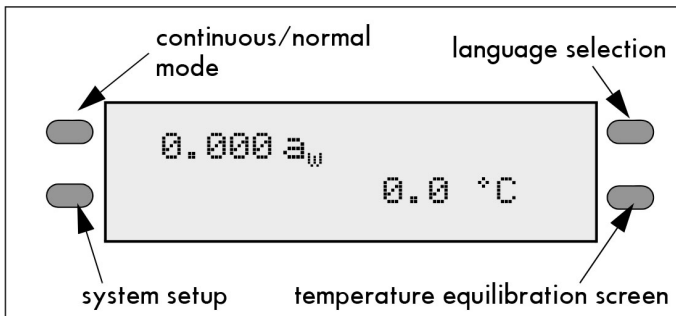
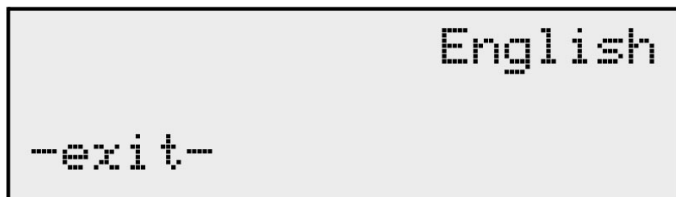

Figure 4: Main Menu Button Options Diagram

5.2 Changing Languages

The AquaLab comes to you with English as the default on-screen user language. If you prefer not to use English, you can change it to one of a variety of other languages: German, French, Spanish, Italian, Swedish, Danish, Norwegian, Czech, Portuguese, Japanese, Polish or Finnish. You can change languages by simply pressing the

upper right button of the instrument while the drawer knob is in the Open or Load position.

A rectangular display screen with a black border. The word "English" is displayed in a pixelated font in the upper right corner. In the lower left corner, the text "-exit-" is displayed in the same pixelated font.

Press the upper right key again, and the next language option (German) will appear:

A rectangular display screen with a black border. The word "Deutsch" is displayed in a pixelated font in the upper right corner. In the lower left corner, the text "-zurück-" is displayed in the same pixelated font.

Each time you press the right button, the display will scroll to the next language option. Select the desired language, then press the lower left button to exit.

5.3 Normal Sampling Mode

The first time you turn on the AquaLab, it will be in normal sampling mode. In this mode, the instrument measures the sample once, after which the instrument notifies you that it is finished with a series of four beeps and a green flashing light. The operator has the ability to change the sampling mode and the audible alarm.

5.4 Continuous Mode

Continuous mode reads your sample continuously until you turn the knob to the Open or Load position. It will read the sample, display the water activity and sample temperature, then begin another read

cycle without turning the knob. Between samples, it will signal you with the green LED flash, accompanied by the beeper (if it is enabled). To toggle between the normal and continuous modes, press the top left button. The display will show a small “c” to the left of the water activity readings.

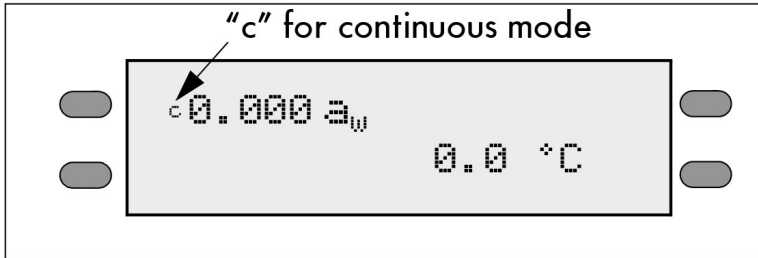
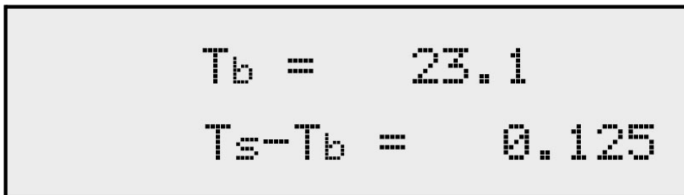

Figure 5: Main Menu with Continuous Mode Enabled

If you press the upper left button again, the “c” will disappear and you will be back in normal sampling mode.

5.5 Temperature Equilibration Screen

To see the temperature difference between your sample and the Aqua Lab, press the lower right button at the main menu. You can only access the temperature screen when the drawer knob is in the Open or Load position. The Temperature Equilibration screen will appear.



The Temperature Equilibration screen shows the temperature difference between the sample (T_s) and the block chamber (T_b), allowing you to quickly check if the sample is too hot, which may cause condensation inside the chamber. Press the lower right button to exit.

5.6 System Configuration

If you press the bottom left button while at the Measurement screen, it will bring you to the System Configuration menu.

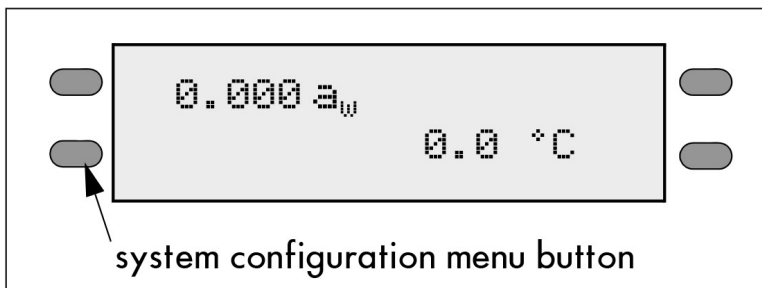

Figure 6: System Configuration Menu Button

The System Configuration menu allows you to make minor system changes. From this menu, you can change the audible alarm after each sample or enter the linear offset adjustment menu.

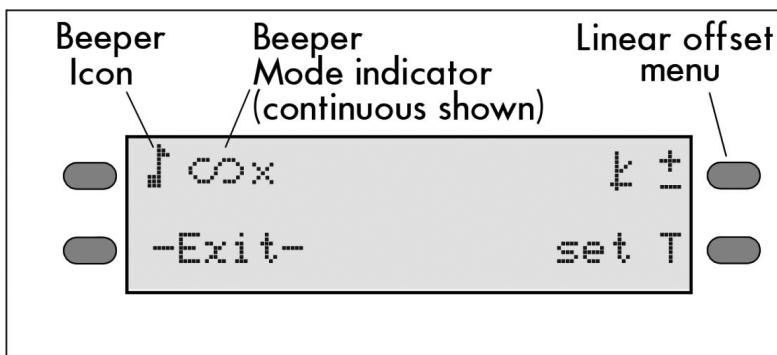

Figure 7: System Configuration Menu

5.6.1 Completion Notification

When you are sampling, the AquaLab has two ways of notifying you that the water activity reading is complete: an audible alarm and a flashing green LED, located on the left front corner of the AquaLab

case. In normal sampling mode, when a sample is started, the LED will flash once, and when it is finished it will flash continuously until the knob is moved to the Open or Load position (if not operating in continuous mode). You cannot turn off or change the LED flashing functions.

There are three audible alarm options, represented by three icons as shown below.

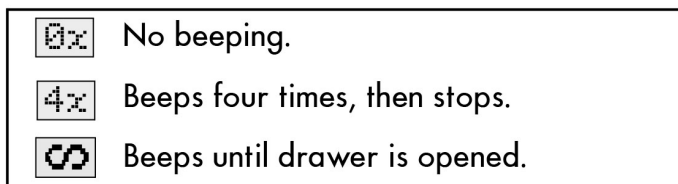

Figure 8: Definition of Beeper Icons

You can turn the audible alarm off completely, switch it to beep momentarily when the sample is finished and then stop, or to beep continuously until the operator turns the the knob to the Open or Load position.

SET T

This selection lets you turn the temp control on and off. If on, the instrument will control to 25 °C. If off, the instrument will be at ambient temperature.

EXIT

You may press the Exit button (the lower left button) to exit back to the main Measurement screen at any time.

Adjusting for Linear Offset

When you need to adjust for linear offset, press the upper right button in the system configuration menu, and you will be brought to the linear offset menu. For more details on linear offset and how to

verify for it, please refer to Section 7.

6 Cleaning and Maintenance

Keeping your AquaLab clean is vital to maintaining the accuracy of your instrument. Dust and sampling debris can contaminate the sampling chamber and must therefore be regularly cleaned out. To clean your instrument, carefully follow these instructions and refer to the labeled diagram below.

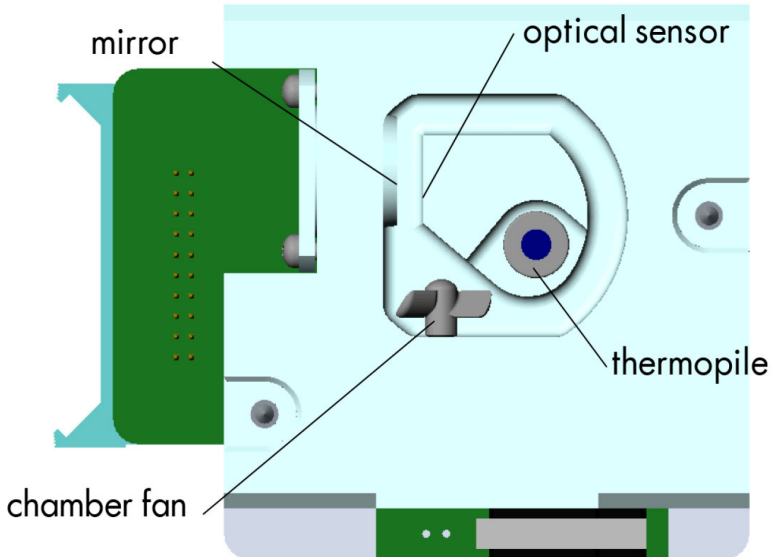

Figure 9: View of Inside Dew Point Block Chamber

Purpose

The purpose for the cleaning procedure is to remove grease, dirt and other soluble substances which can absorb/release water during verification, calibration, and/or sample testing. For a smooth and even dew formation, it requires the mirror to be perfectly clean. If there are any contaminants (e.g. fingerprints) on the mirror, the dew will form unevenly and thus affect the accuracy of the reading.

Cleaning Supplies

Your new instrument comes with the AquaLab Cleaning Kit and instructional DVD. The AquaLab Cleaning Kit comes with all the materials needed to clean one instrument for about a year. Every time you send in your instrument for the annual calibration service, you will receive a new cleaning kit. The following supplies are included in the cleaning kit.

- Spatula (a thin plastic rod)
- Deionized Water for Cleaning
- Decagon Cleaning Solution
- Kimwipes[®] and Kimwipe strips
- Activated Charcoal

Note: Wash your hands with soap and water and/or use clean lab gloves before starting the cleaning procedure. This will prevent oils from contaminating the cleaning materials, the sample chamber and/or the sensors.

6.1 Cleaning the Block and Sensors

6.1.1 Accessing the Block

Turn the power off on your AquaLab (switch in back.) Next, remove the case lid screw located on the back panel. Carefully remove the lid by pulling the back of the lid upward and then sliding the lid back (away from the front of the case) and off. Unscrew the two thumbscrews that secure the sensor block. Unplug the cable with the 20-pin socket that attaches the block to the main circuit board by releasing the two locking levers that are on either side of the socket. Carefully lift the block straight up from its mount. Turn the block over to expose the chamber cavity as shown in the illustration at the beginning of this Section.

Note for Volatiles Block: If cleaning an AquaLab Pre Volatiles Block, follow the cleaning procedures listed below being especially careful not to get cleaning solution or alcohol on the capacitance sensor filter. Repeated exposure of cleaning materials or contaminants to the filter may cause inaccurate readings. If the filter appears contaminated,

replace the filter while being careful not to touch or clean the sensor behind the filter.

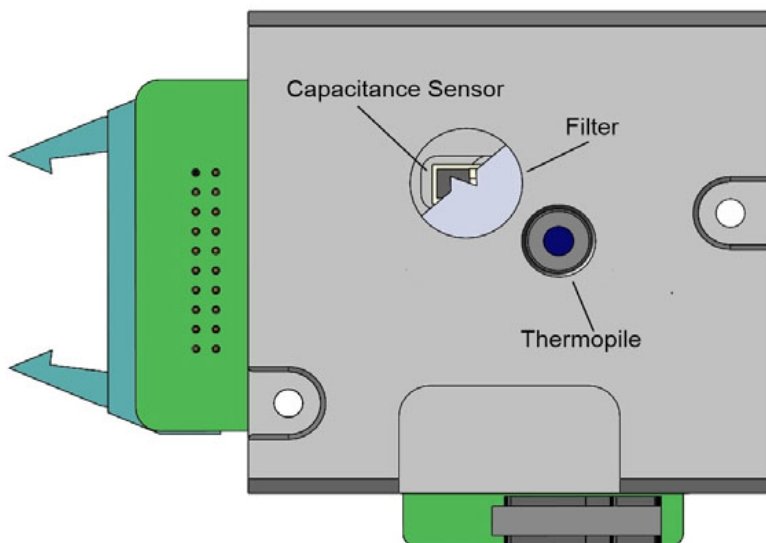

Figure 10: View of Inside Volatiles Block Chamber

6.2 Cleaning Procedures

Cleaning your AquaLab is a multi-step procedure which involves washing, rinsing, and drying for each specific area.

1. Cleaning the Sample Chamber

Note: Be extremely careful not to damage the fan blades (see illustration) when cleaning the chamber.

- (a) Remove any debris that may have collected within or around the sample chamber.
- (b) Wrap a new Kimwipe around the end of the spatula (thin plastic rod) and moisten it with Decagon Cleaning Solution or with Isopropyl Alcohol.

Note: Do not dip a used Kimwipe into your cleaning solution (the cleaning solution will become contaminated).

- (c) Wash — Clean all surface areas of the sample chamber, including the edge where the sample cup seals to the block chamber. You may need to replace the Kimwipe if it becomes too dirty during this process.
- (d) Rinse — Repeat steps b and c using new Kimwipes with distilled water.
- (e) Dry — Repeat steps b and c using new, dry Kimwipes to help remove any moisture remaining from the cleaning.

Note: Do not reuse Kimwipes

- (f) Visually inspect the sample chamber for cleanliness, clean again if necessary.

2. Clean the Mirror

- (a) Wrap a new Kimwipe around the end of the spatula and moisten it with Decagon Cleaning Solution.
- (b) Wash — Swipe the moistened Kimwipes across the mirror once. (A single swipe is usually sufficient to remove contaminants.)
- (c) Rinse — Repeat steps a-b using new Kimwipes moistened with distilled water instead of cleaning solution.
- (d) Dry — Repeat steps a-b using a new, dry Kimwipes to help remove any moisture remaining from the cleaning.
- (e) Visually inspect the mirror for cleanliness. Clean again if necessary.

3. Clean the Thermopile and Optical Sensor

- (a) Wrap a new Kimwipe around the end of the spatula and moisten it with Decagon Cleaning Solution.
- (b) Wash — Swipe the moistened Kimwipe across thermopile and optical sensor. (A single swipe across the sensor is usually sufficient to remove contaminants.)
- (c) Rinse — Repeat steps a-b using new Kimwipes moistened with distilled water instead of cleaning solution.

- (d) Dry — Repeat steps a-b but use new and dry Kimwipes to help remove any moisture remaining from the cleaning.
- (e) Visually inspect the thermopile and optical sensor for cleanliness. Clean again if necessary.

4. Clean the Sample Drawer

- (a) With the top block removed, remove the drawer from the AquaLab.
- (b) Clear out any debris with compressed air or by wiping out with Kimwipes.
- (c) Wash — Wet the Kimwipes with Decagon Cleaning Solution and wipe down the cup holder, then the rest of the drawer.
- (d) Rinse — Wet a Kimwipe with Distilled water and clean again as in the Wash step.
- (e) Dry — With a dry Kimwipe, dry as in the Wash step.

Note: Be careful not to lose the metal base of the cup holder.

5. Additional Drying Time

- (a) Visually inspect the sample chamber and sensors for contaminants, including moisture. If necessary, repeat the cleaning process using new Kimwipes.
- (b) Let stand for about five minutes to ensure the sample chamber is dry.

6.3 Checking Calibration

After you have cleaned the chamber and other parts of your AquaLab, it is important to check the instrument performance in order to correct for any linear offset that may have occurred during the cleaning process.

Before you check the instrument we recommend that you run a sample of the activated charcoal pellets provided in your AquaLab cleaning kit. This cleans the air inside the chamber, helping it come back

to a stable sampling environment.

Verify the linear offset against known calibration standards according to the procedure described in the next Section. If a linear offset has occurred, refer to “adjust for linear offset” section in Section 7 for directions on how to correct for linear offset. If, after adjusting for linear offset, your instrument is still not reading samples correctly, please contact Decagon for support.

7 Verification and Calibration

It is important to verify the AquaLab water activity calibration against known standards to guarantee optimal performance and accuracy. Decagon recommends verification daily, once per shift, or before each use (if used infrequently).

Note: To avoid inaccurate water activity readings, verification standards should be used once immediately after opening and not stored in sample cups for repeated use.

7.1 Water Activity Verification

AquaLab uses the chilled-mirror dew point technique to determine water activity. Because this is a primary measurement of relative humidity, no calibration is necessary; however, it is important to periodically check for linear offset. The components used by the instrument to measure water activity are subject to contamination which may affect the AquaLab performance. Contamination will impact the accuracy of the instrument. We refer to this change in readings as “linear offset.” Frequent verification will assure that your AquaLab performs correctly. Linear offset is checked by using two different calibration standards.

7.2 Calibration Standards

Calibration standards are specially prepared salt solutions having a specific molality and water activity constant which are accurately measurable. The calibration standards that were sent with your initial shipment are very accurate and readily available from Decagon. Using calibration standards to verify accuracy can greatly reduce preparation errors. For these reasons, we recommend using standards available through Decagon for the most accurate verification of your AquaLab performance.

Performance Calibration Standards come in six water activity levels: 0.250, 0.500, 0.760, 0.920, 0.984 and 1.000 a_w . The standards

are produced under a strict quality assurance regime. Please contact Decagon Devices to order additional standards via email at sales@aqualab.com or by phone at 509-332-5601.

Table 1: Verification Flowchart

Calibration Standard @ 25 °C	Water Activity
13.40 mol/kg LiCl	0.250 ±0.003
8.57 mol/kg LiCl	0.500 ±0.003
6.00 mol/kg NaCl	0.760 ±0.003
2.33 mol/kg NaCl	0.920 ±0.003
0.50 mol/kg KCl	0.984 ±0.003
Distilled Water	1.000 ±0.003

Note: If you need to obtain a Safety Data Sheet (SDS) for any of these standards, a printable version is available on our website at <http://www.decagon.com/education/safety-data-sheets/>.

To use a calibration standard, remove the twist top and pour the contents into an AquaLab sample cup. If for some reason you cannot obtain Decagon’s calibration standards and need to make a saturated salt solution for verification, refer to Appendix A.

In the Pre Capacitance models, the capacitance sensor can hold a memory of high water activity samples such as distilled water or the 0.984 a_w standard. If you verify calibration with one of these high water activity standards, you will need to wait an hour to allow the capacitance sensor to dry before testing samples of lower water activity or the results may be slightly high.

7.3 Calibration

When to Verify for Linear Offset

Linear offset should be checked against two known calibration standards either daily, once per shift or before each use. Linear offset should never be verified solely against distilled water, since it does

not give an accurate representation of the linear offset. For batch processing, the instrument should be checked regularly against a known standard of similar water activity. It is also a good idea to check the offset with a standard of similar water activity when the general water activity range of your sample is changing. Checking the water activity of a standard solution will alert you to the possibility of unit contamination or shifts in the linear offset from other causes.

Note: The linear offset process is the same for both the dew point and volatiles block except that the accuracy for the capacitance sensor in the volatiles block is $\pm 0.015 a_w$.

Verification

To verify for linear offset of your AquaLab, do the following:

1. Choose a calibration standard that is below or close to the water activity of the sample you are measuring.

Note: The AquaLab needs to warm up for approximately 15 minutes to make accurate readings.

2. Empty a vial of the chosen calibration standard into a sample cup and place it in the AquaLab sample drawer. Make sure that your standard is as close to the instrument temperature as possible.

Note: Make sure the rim of the sample cup is clean.

3. Carefully slide the drawer closed and turn the knob to the Read position.
4. Take two readings. The water activity readings should be within $\pm 0.01 a_w$ of the given value for the calibration standard. See Appendix B for the correct water activity value of Decagon's standards at temperatures other than 25 °C.
5. If your AquaLab is reading within $\pm 0.01 a_w$ of the calibration standard, choose a second calibration standard that would border the upper range of water activity you plan to test. For example, if you plan to test for water activity readings ranging

between 0.713 and 0.621 you should use the 8.57 mol/kg LiCl (0.50 a_w) standard for your first verification and the 6.0 M, NaCl (0.76 a_w) for the second verification.

6. Prepare a sample cup of the second calibration standard and make two readings. The water activity reading for the second calibration standard should be within $\pm 0.01 a_w$.
7. If either one of the verifications is not correct, it is probably due to contamination of the sensor chamber. For cleaning instructions, see Section 6. After cleaning, repeat verification from step two.
8. If you are consistently getting readings outside the water activity of your first calibration standard by more than $\pm 0.01 a_w$, a linear offset has probably occurred. In this case, adjust the reading on the calibration standard to its correct value as outlined in the next section.

7.3.1 Adjusting for Linear Offset

1. Once you are certain that a linear offset has occurred, enter the system configuration menu by pressing the lower left button from the Measurement screen. Press the upper right button in the system configuration menu to enter the linear offset menu. You will be guided through the linear offset routine.
2. If you wish to continue, press the button next to “yes.” To return to the Measurement screen, press the button next to “no.” After selecting “yes,” the screen will prompt you to “place standard in the drawer and read.”



place standard
in drawer and read

3. Empty the whole vial of a calibration standard into a sample cup. We recommend using the 6.00 mol/kg NaCl (0.76 a_w). Do

not adjust for the offset using distilled water. Ensure the rim and outside of the cup are clean. Place the prepared sample cup in the AquaLab sample drawer.

Note: The same calibration standard may be used to verify and adjust the linear offset.

4. Close the drawer, being especially careful so the solution will not splash or spill and contaminate the chamber.
5. Turn the drawer knob to the Read position to make a water activity reading.

Note: If you decide at this point not to continue with the linear offset program, just return the knob to the Open or Load position and remove the sample.

After your AquaLab has finished sampling the calibration standard, the Adjustment screen will prompt you to adjust the a_w value.

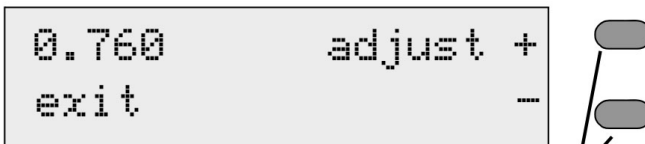

use these buttons to adjust the value

6. Adjust the water activity value to its proper value for the particular calibration standard you are measuring by pressing the up or down buttons until it displays the correct value. When the value is correct, press the Exit button to store this new value.

Note: This is the only menu where these buttons can change the linear offset, so you will not hurt anything by pressing these buttons in other menus.

7. Measure the calibration standard again in the normal sampling mode. It should read the proper value at a given temperature

for that calibration standard (see Appendix B).

8. Measure the water activity of a second calibration standard according to the verification procedure described above. If both verification readings are within $\pm 0.01 a_w$ then the instrument is ready to begin testing.

Note: The flowchart in Figure 11 is a graphical representation of the steps 1 through 8 for check linear offset.

If you still have incorrect verification readings after cleaning the chamber and/or adjusting for linear offset, contact Decagon for further instructions at support@aqualab.com or 509-332-5601. If you purchased your AquaLab from one of our international distributors, please contact them for local service and support.

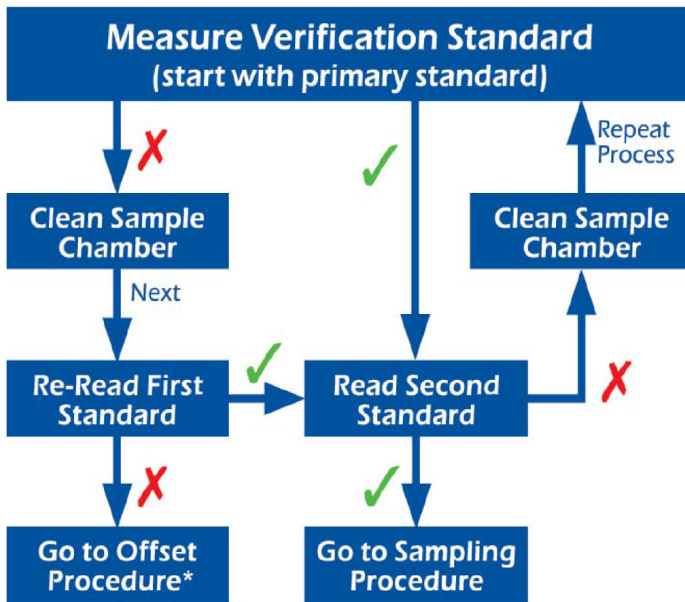

*See the verification section in the operator's manual

Figure 11: Measure Verification Standard Flowchart

8 Sample Preparation

Your AquaLab will continually provide accurate water activity measurements as long as its internal sensors are not contaminated by improperly-prepared samples. Careful preparation and loading of samples will lengthen time between cleanings and will help you avoid cleaning and downtime.

8.1 Preparing the Sample

1. **Make sure the sample to be measured is homogeneous.** Multicomponent samples (e.g., muffins with raisins) or samples that have outside coatings (like deep-fried, breaded foods) can be measured, but may take longer to equilibrate. For samples like these, the AquaLab may take more than five minutes to give an accurate reading, or may require multiple readings of the same sample. We discuss measuring the water activity of these types of products in detail later in this section (see Samples Needing Special Preparation).
2. **Place the sample in a disposable sample cup, completely covering the bottom of the cup, if possible.** The AquaLab is able to accurately measure a sample that does not (or cannot) cover the bottom of the cup. For example, raisins only need to be placed in the cup and not flattened to cover the bottom. A larger sample surface area increases instrument efficiency by providing more stable infrared sample temperatures. It also speeds up the reading by shortening the time needed to reach vapor equilibrium.
3. **Do not fill the sample cup more than half full. Over-filled cups contaminates the sensors in the sensor chamber.** Filling the sample cup does not make the readings faster or more accurate. There only needs to be enough sample in the cup to allow the water in the sample to equilibrate with the water in the vapor phase and not change the moisture content of the sample. Covering the bottom of the sample cup provides enough sample to get an accurate reading.

4. **Make sure the rim and outside of the sample cup are clean.** Wipe any excess sample material from the rim of the cup with a clean Kimwipe. Material left on the rim or the outside of the cup can contaminate the sensor chamber and be transferred to subsequent samples.
5. **If a sample reads at some other time, put the disposable sample cup lid on the cup to restrict water transfer.** For longterm storage, seal the lid by placing tape or Parafilm[®] completely around the cup to lid junction.
6. **Be consistent in sample preparation practices.** If you crush, grind, or slice your sample, be consistent in the method you use in order to obtain reproducible results.

8.2 Samples Needing Special Preparation

AquaLab reads most materials in less than five minutes, depending on which mode you are operating in. Some samples, however, may require longer reading times, due to the nature of the material you are sampling. These materials need additional preparation to ensure quick, accurate readings. To find out whether special sample preparation is necessary, take a reading and see how long it takes to find the water activity. If it takes longer than six minutes, remove the sample and take a reading of a calibration standard. This will ensure that the sample itself is causing the long read time, and that there is not a problem with your instrument. If the calibration standard also takes longer than six minutes to sample, refer to Section 11 of this manual for more information.

Coated and Dried Samples

Samples with coatings such as sugar or fat often require longer reading times, because it takes longer for them to equilibrate. If this is the case for your samples, do not worry that something is wrong with your instrument; it simply means that your particular sample takes longer than most to equilibrate water with its outside environment.

To reduce the time needed to take a water activity reading for coated

or dried samples, one thing you can do is crush, slice, or grind the sample before putting it in the sample cup. This increases the surface area of the sample, thus decreasing reading times. Keep in mind, however, that modifying some samples may alter their water activity readings.

For example, a candy may have a soft chocolate center and a hard outer coating. The water activity reading for the center and the outer coating are different, so one would need to evaluate which part of the sample needed to be measured before crushing it. When the candy is crushed, for example, the water activity will represent the average water activity of the entire sample; whereas leaving the candy whole will give a reading for the coating, which may act as a barrier to the center.

Note: If you crush, grind, or slice your sample, be consistent in the method you use in order to obtain reproducible results.

Slow Water-Emitting Samples

Some extremely dry, dehydrated, highly viscous water-in-oil (butter), high fat, or glassy compositions may have increased read times, due to their moisture sorption characteristics. AquaLab may require up to ten minutes to reach an accurate measurement of water activity and nothing can be done to decrease the reading times of these types of samples. For faster reading, it is important to have the water activity of the chamber at or below the water activity of these type of samples. This causes the sample to release water to the vapor phase and equilibrate with the chamber. If the water activity of the headspace is greater than this type of sample, a long period of time will be required to reach equilibrium and it may affect the water activity of the sample.

Volatile Samples

The AquaLab Pre with the chilled mirror dew point sensor will give accurate readings on most samples. However, samples with certain volatiles in high enough concentrations may give inaccurate water

activity values. This is because the volatiles condense on the mirror during the reading process, but do not evaporate from the mirror as water does. As a result, the reading on volatiles will not be accurate. The concentration of volatiles that will cause interference is variable and matrix dependent. The most effective method to determine if volatiles are a problem is to look for incorrect standard readings after reading the sample.

If you will be testing samples with volatiles on a regular basis that need a more accurate reading, you can purchase a volatiles block for your Pre that has a capacitance sensor or upgrade to the Decagon's Series 4TEV which are both designed for measuring volatiles such as propylene glycol and ethanol. For more information about the Pre Capacitance Sensor, the Series 4TEV, or the TDL contact Decagon Devices at support@aqualab.com or 509-332-5601.

8.3 Low Water Activity

Samples that have a water activity of less than about 0.03 cannot be accurately measured with the normal AquaLab Pre model. Samples with such low water activity values are rare. When a sample water activity value is below its ability to accurately measure, your AquaLab will display an error message indicating the last reading it could make on that particular sample. For example, say you are measuring a dry sample and the screen returns a reading with a_w less than the minimum standard.



This screen indicates that the last water activity reading the AquaLab measured on this sample was 0.031 at $24.7 \text{ } ^\circ\text{C}$. Therefore, the actual water activity of the sample is lower than the instrument components can measure. If your sample is not extremely dry but is still getting the error message, refer to Section 11 for other possible explanations.

Samples not at Room Temperature

Samples that are four degrees colder or warmer than the instrument (chamber) temperature will need to equilibrate to ambient temperature before a fast and accurate reading can be made. Rapid changes in temperature over short periods of time will cause the water activity readings to rise or fall until the temperature stabilizes. When the temperature stabilizes within one or two degrees of the chamber temperature, you can proceed with normal measurements.

High water activity samples that are warmer than the chamber temperature can cause condensation inside the measuring chamber, which will adversely affect subsequent readings. A warning message appears if the sample temperature is more than 4 °C above chamber temperature.



sample too hot

If this message appears, immediately remove the sample from the instrument, place a lid on the cup, and allow the sample to cool to within 4 °C of the instrument before measuring.

Samples that are lower than 4 °C of the instrument temperature will cause long read times. The sample temperature must be within one or two degrees of the chamber temperature before fast and accurate readings can be made.

9 Taking a Reading

9.1 Measurement Steps

Once you have prepared your sample, you are ready to take readings. The process is simple.

1. Turn the sample drawer knob to the Open or Load position and pull the drawer open.
2. Place your prepared sample in the drawer. Check the top lip of the cup to make sure it is free from sample residue (remember, an over-filled sample cup may contaminate the chamber sensors).
3. Carefully slide the drawer closed, being especially careful if you have a liquid sample that may splash or spill and contaminate the chamber.
4. Turn the sample drawer knob to the Read position to seal the sample cup with the chamber. The screen will report that the measurement has started.



```
chamber sealed  
measurement started
```

This will start the read cycle. Length of read times may vary depending on temperature differences between the chamber and your sample, and other properties of your sample.

Note: Samples that have a large difference in water activity from previous samples may need extra time to reach equilibrium, since some of the previous sample's atmosphere stays in the chamber after measurement.

9.2 How AquaLab takes Readings

The AquaLab reading cycle continues until the rate of change of three consecutive readings are less than 0.0005 of each other. The instrument crosses the dew threshold numerous times to ensure the accuracy of readings. When the instrument has finished its read cycle, the water activity is displayed, accompanied by the LED flash and beeper (if you have the beeper enabled).

9.3 Cautions

- **Never leave a sample in your AquaLab after a reading has been taken.** The sample may spill and contaminate the instrument chamber if the instrument is accidentally moved or jolted.
- **Never try to move your instrument after a sample has been loaded.** Movement may cause the sample material to spill and contaminate the sample chamber.
- **Take special care not to move the sample drawer too quickly when loading or unloading liquid samples,** in order to avoid spilling.
- **If a sample has a temperature that is four degrees higher (or more) than the AquaLab chamber, the instrument will display “the sample too hot” message to alert you to cool the sample before reading.** Although the instrument will measure warmer samples, the readings may be inaccurate. Warm samples can cause condensation in the chamber if they have a high water activity.



sample too hot

- **The physical temperature of the instrument should be between 4 and 50 °C.** Between these ambient temperatures, AquaLab will measure samples of similar temperature quickly and accurately.
- **If you are sampling and a triangular warning symbol appears in the top right corner, this indicates that the mirror has become too dirty to give accurate measurements,** and you need to clean the mirror and chamber before continuing to sample. For more details about this symbol, please refer to Section 11. For cleaning instructions, refer to Section 6.



- **If a sample has a water activity lower than about 0.03, AquaLab will display a message, accompanied by the flashing light, notifying you that your sample is too dry to be accurately measured by the AquaLab.**

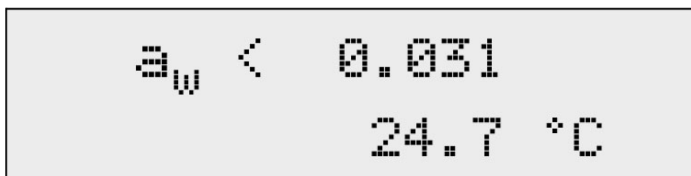

This message will stay on the screen until you open the sample drawer. If you know that your sample water activity is above what the screen is telling you, your instrument sensors may have been contaminated and will need to be cleaned (see Section 6) or serviced (see Section 12).

10 Computer Interface

Your AquaLab Pre comes with a RS-232 to USB interface cable. Using this cable, you can connect to your AquaLab and send water activity data to a computer for further analysis and storage. The interface is run through the AquaLink 4 Software or a terminal communication program.

Note: You can find the driver for this cable on our website at <http://www.aqualab.com/support/usb-cable-adaptor-driver> or on the AquaLink trial included with your instrument.

10.1 AquaLink 4 Software

An optional software program, AquaLink 4, is available for use with your AquaLab. AquaLink 4 is a Windows based program designed for data collection and customized report generation for all AquaLab models. AquaLink 4 logs water activity, temperature, time of measurement, and date stamps along with other information. AquaLink 4 also has sample identification and comment fields that you can use to help annotate the data your AquaLab is gathering.

A 30 day trial of this program is included with your AquaLab Pre. If you are interested in purchasing a license of AquaLink 4, contact Decagon or your local distributor. On the next page is a sample picture of the AquaLink 4 program. Figure 12 demonstrates a sample AquaLink data set.

Date Time	Device	Water Activity	°C	Test Time	User	Type
2000-Jan-01 00:00:00	S40001234	0.0000	0.00	0.0	Admin	Normal Dew
2000-Jan-01 22:14:07	S40001234	0.0010	1.43	3.0	Admin	Normal Dew
2000-Jan-02 20:28:14	S40001234	0.0020	2.86	2.9	Admin	Normal Dew
2000-Jan-03 18:42:21	S40001234	0.0030	4.29	5.9	Admin	Normal Dew
2000-Jan-04 16:56:28	S40001234	0.0040	5.72	5.8	Admin	Normal Dew
2000-Jan-05 15:10:35	S40001234	0.0050	7.15	5.7	Admin	Normal Dew
2000-Jan-06 13:24:42	S40001234	0.0060	8.58	5.5	Admin	Normal Dew
2000-Jan-07 11:38:49	S40001234	0.0070	10.01	5.4	Admin	Normal Dew
2000-Jan-08 09:52:56	S40001234	0.0080	11.44	5.3	Admin	Normal Dew
2000-Jan-09 08:07:03	S40001234	0.0090	12.87	5.2	Admin	Normal Dew
2000-Jan-10 06:21:10	S40001234	0.0100	14.30	5.1	Admin	Normal Dew
2000-Jan-11 04:35:17	S40001234	0.0110	15.73	5.0	Admin	Normal Dew
2000-Jan-12 02:49:24	S40001234	0.0120	17.16	4.8	Admin	Normal Dew
2000-Jan-13 01:03:31	S40001234	0.0130	18.59	4.7	Admin	Normal Dew
2000-Jan-13 23:17:38	S40001234	0.0140	20.02	4.6	Admin	Normal Dew
2000-Jan-14 21:31:45	S40001234	0.0150	21.45	4.5	Admin	Normal Dew
2000-Jan-15 19:45:52	S40001234	0.0160	22.88	4.4	Admin	Normal Dew
2000-Jan-16 17:59:59	S40001234	0.0170	24.31	4.3	Admin	Normal Dew
2000-Jan-17 16:14:06	S40001234	0.0180	25.74	4.1	Admin	Normal Dew
2000-Jan-18 14:28:13	S40001234	0.0190	27.17	4.0	Admin	Normal Dew
2000-Jan-19 12:42:20	S40001234	0.0200	28.60	3.9	Admin	Normal Dew
2000-Jan-20 10:56:27	S40001234	0.0210	30.03	3.8	Admin	Normal Dew

Figure 12: AquaLink 4 Screen

10.2 Using a Communication Program

There are several terminal program options. Decagon has its own terminal program (DecaTerm) which can be downloaded from www.soft-ware.decagon.com/DecaTerm.zip. Two other options are TeraTerm, which is a free program that can be found on the internet and Hyperterminal which came standard with Windows prior to Windows 7.

To use any of these terminal programs with your AquaLab, follow the instructions for the program with the following settings. Be sure to power on the AquaLab prior to connecting the USB interface cable to your computer.

- Choose correct Com port
- Set/Verify Com Properties

- ✓ Bits per second 9600
- ✓ 8 Databits

- ✓ No parity
- ✓ 1 stop bit
- ✓ Flow control set to none

After successfully connecting the AquaLab to your computer and upon completion of a water activity reading, the data will display in the as measurement time (minutes), sample temperature, and water activity. Table 2 shows an example data return.

Table 2: Terminal Data

Time since chamber was closed	Temperature ($^{\circ}\text{C}$)	a_w
3.1,	24.3,	0.862

11 Troubleshooting

AquaLab is a high performance, low maintenance instrument, designed to have few problems if used with care. Unfortunately, sometimes even the best operators using the best instruments encounter technical difficulties. Below is quick reference guide that will direct you to detailed solutions of some problems that may occur. If these remedies still do not resolve your problem, then please contact Decagon for help (see Customer Support in Section 1). Table 3 provides a list of some problems that may occur.

Note: If you purchased your Decagon instrument from one of our international distributors, please contact them for local service and support.

Table 3: Troubleshooting Quick Guide

If this problem occurs:	Refer to:
AquaLab will not turn on	Problem #1
Readings are slow or inconsistent	Problem #2
A_w solution readings are too high/low to adjust	Problem #3
Screen displays "Sample too hot"	Problem #4
Screen displays " $a_w < x.xxx$ "	Problem #5
Screen displays " $a_w > 1.0$ "	Problem #6
Verification is not correct	Problem #7
Triangle Appears on Upper Right Corner	Problem #8
Screen displays "Block Failure" upon power up	Problem #9

1.PROBLEM:

AquaLab will not turn on.

SOLUTIONS:

1. Check to make sure your power cord is securely attached to the back of the instrument and it is plugged into the power outlet.
2. A power surge may have caused a fuse to blow. To change the fuses, follow instructions a through d.
 - (a) Unplug the power cord.

- (b) Locate the panel where the power cord plugs in. The fuse box is on the right side of that panel. Press in on the release tab and pull the fuse-holder out. Pull the broken fuse(s) out and replace with a 1.25 Amp 250V fuse.

Caution: Do not use any other kind of fuse or you will risk damage to your instrument as well as void your warranty.

- (c) Replace the fuse-holder and push it into the fuse-well until the release tab snaps in place.
- (d) Connect the power cord and turn your instrument on. If the fuse blows again, a failed component may be causing the problem. Contact Decagon to make arrangements for repairs.

2. PROBLEM:

Readings are slow or inconsistent.

SOLUTIONS:

1. The sample chamber may be dirty. Refer to Section 6 for directions on cleaning the sample chamber.
2. The temperature difference between the sample and the block chamber may be too great. The sample will need to equilibrate to instrument temperature before a fast and accurate reading can be made. (Refer to Section 8, Samples Not at Room Temperature.)
3. Some products absorb or desorb moisture very slowly, causing measurements to take longer than usual, and nothing can be done to speed up the process. Refer to Section 8 for further explanation.
4. Your sample may contain volatiles. Volatiles are known to cause unstable readings, because they condense on the surface of the chilled mirror and alter readings. Please refer to the volatiles section in Section 8 for hints on reducing difficulties with measuring samples with propylene glycol. If you have fur-

ther questions regarding the measurement of volatiles contact Decagon.

5. A fan blade in the block chamber may be broken or bent. If even salt standards take a long time to read, and the sample chamber is clean, you may have a broken chamber fan blade. This is especially likely if you have just cleaned the chamber. If you suspect this may have happened, contact Decagon for details on replacement.

3. PROBLEM:

Water activity readings on verification standards are too high/low and a linear offset adjustment cannot be made any higher/lower.

SOLUTIONS:

1. The thermopile in your chamber, which measures sample temperature, may have become contaminated. Refer to Section 6 for directions on cleaning.
2. The chamber mirror may be dirty. Refer to Section 6 for directions on cleaning.

4. PROBLEM:

Message on screen says sample is too hot.



SOLUTION:

Your sample temperature is too high for the instrument to equilibrate with it in a reasonable amount of time. The instrument and sample need to be in temperature equilibrium before accurate measurements can be made. Therefore, very cold samples will take a very long time to measure for the same reason. To avoid this problem,

make sure to only measure samples that are at the same temperature as the instrument.

5. PROBLEM:

Message on screen displays $a_w <$ below instrument detection limits.



SOLUTIONS:

1. The sample is too dry for the instrument to read accurately. If your sample has a water activity that is less than below the detection limits of the instrument, this message will come up. Essentially, it means that there is not enough sample moisture to condense on the mirror and provide a reading.
2. Or the mirror may be dirty. Try cleaning the mirror and chamber and measuring the sample again.

6. PROBLEM:

Message on screen displays " $a_w > 1.0...$

SOLUTION:

The Cooler is damaged and will need to be serviced by Decagon. See Section 12 for detailed instructions.

7. PROBLEM:

Verification is not correct.

SOLUTION:

1. The sample chamber and mirror need to be cleaned. See Section 6 for detailed cleaning instructions. If verification is still not correct, then linear offset has occurred.
2. Verify and Adjust for Linear offset. After you have cleaned the sample chamber and mirror (Section 7) you will need to use a Verification Standard to verify and adjust for Linear offset as described in Section 7.

8. PROBLEM:

A small triangle appears in the upper right corner after sampling.

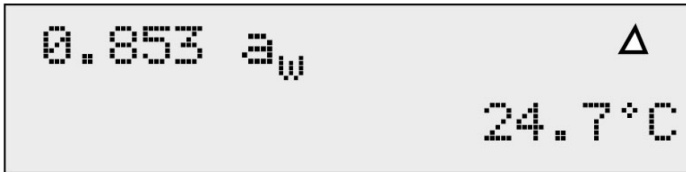
**SOLUTION:**

The mirror used for dew point measurements requires cleaning. Follow the instructions outlined in Section 6: Cleaning and Maintenance before trying to run your sample again. If this message continues to appear, contact Decagon for further options.

9. PROBLEM:

The block failure screen comes up after turning on the Pre.

**SOLUTIONS:**

1. The block is not plugged in to the motherboard. Open the case and check to make sure that the small ribbon cable that connects the block to the motherboard is snapped and locked in place.
2. One or more components has failed on the block circuit board. If the block is properly plugged in to the motherboard and this message appears, it is likely that one or more of the components have failed on the block circuit board. If you press Exit at this prompt, the instrument will not have values for the component that has failed, which will lead to incorrect readings. If this message appears and you continue to sample, Decagon cannot be liable for errors in reading that may occur. Contact Decagon for a solution to this problem.

11.1 Component Performance Screen

If, after cleaning your instrument and reading the other troubleshooting hints, you have reason to believe that one of the components of your AquaLab may be causing measurement error, then you can access the Performance screen that displays values for component performance. This is done either by holding down the lower right button while turning on the instrument, or by first pressing the lower left button (system configuration menu), then the upper right button (linear offset menu) and then the upper left button. The screen will display component performance values.

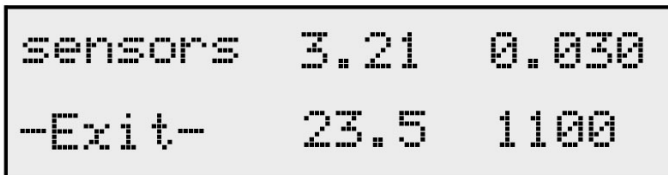

sensors	3.21	0.030
-Exit-	23.5	1100

The Performance screen returns four values. The top left value is the value the thermocouple is reading. It is basically the difference in temperature between the block and the mirror. It should typically have a value of 3, ± 0.3 . If this is 0, there is something wrong with the thermocouple. The top right value is the value read by the

thermopile, which is the temperature difference between the block and what it “sees” below it (the sample, when reading). This value should be around zero, but will change when you change the drawer position. The bottom left value is the block temperature. This value should be around ambient temperature. The bottom right value is the mirror reflectance voltage, in units of millivolts. This value should normally be between 400 and 2400 mV, and should be steady.

You cannot change anything in this screen, but it is here to give you an indication of the component performance. If you notice that any of these values are not what they should be, contact Decagon for further instruction. Press the Exit button to return to the main menu.

12 Support and Repair

Note: If you purchased your AquaLab from one of our international distributors, please contact them. They will be able to provide you with local support and service.

When encountering problems with your AquaLab (that you unable to resolve with the help of this manual), please contact Decagon Customer Support at support@aqualab.com, 509-332-5601 or fax us at 509-332-5158. Please have the serial number and model of the instrument ready.

All AquaLabs returning to Decagon for servicing must be accompanied with a Return Material Authorization (RMA) form. Prior to shipping the instrument, please contact a Decagon customer support representative to obtain an RMA.

Shipping Directions

The following steps will help to ensure the safe shipping and processing of your AquaLab.

1. Ship your AquaLab in its original cardboard box with suspension packaging. If this is not possible, use a box that has at least four inches of space between your instrument and each wall of the box.
2. Place the AquaLab in a plastic bag to avoid disfiguring marks from the packaging.
3. Do not ship the power cord or serial cable.
4. If the original packaging is not available, pack the box moderately tight with packing material (e.g. styrofoam peanuts or bubble wrap), ensuring the instrument is suspended in the packing material.
5. On the RMA form, please verify the ship to and bill to information, contact name, and problem description. If anything is incorrect please contact a Decagon representative.

6. Tape the box in both directions for added support.
7. Include the RMA number in the attention line on the shipping label.

Ship to:

Decagon Devices Inc.
ATTN: RMA (insert your RMA #)
2365 NE Hopkins Court
Pullman, WA 99163

12.1 Repair Costs

Manufacturer defects and instruments within the one-year warranty will be repaired at no charge. Non-warranty repair charges for parts, labor and shipping will be billed to you. An extra fee may be charged for rush work. Customers must ask Decagon to provide an estimated repair cost.

12.2 Loaner Service

Decagon has loaner instruments to keep you measuring water activity while your instrument is being serviced. If your AquaLab is still under calibration warranty or you have a service plan with your instrument, there is no charge for the loaner service.

13 Further Reading

13.1 Water Activity Theory & Measurement

Bousquet-Ricard, M., G. Qualyle, T. Pharm, and J. C. Cheftel. 1980. Comparative study of three methods of determining water activity in intermediate moisture foods. *Lebensm Wiss Technol* 13:169-173.

Cazier, J.B., and V. Gekas. 2001. Water activity and its prediction: a review. *International Journal of Food properties* 4(1):35-43.

Chirife, J., G. Favetto, C. Ferro-Fontn, and S.L.Resnik. 1983. The water activity of standard saturated salt solutions in the range of intermediate moisture foods. *Lebensm Wiss Technol* 16:36-38.

Duckworth, R. 1975. *Water relations of foods*. Academic Press, New York.

Gmez, R., and J. Fernandez-Salguero. 1992. Water activity and chemical composition of some food emulsions. *Food Chem* 45:91-93.

Greenspan, L. 1977. Humidity fixed points of binary saturated aqueous solutions. *J Res Nat Bur Stand - A Phys Chem* 81A:89-96.

Karmas, E. 1981. Measurement of moisture content. *Cereal Foods World* 26:332-334.

Kitic, D., D.C. Pereira-Jardim, G.J. Favetto, S.L. Resnik, and J. Chirife. 1986. Theoretical prediction of the water activity of standard saturated salt solutions at various temperatures. *Journal of Food Science* 51:1037-1042.

Labuza, T.P., and R. Contreras-Medellin. 1981. Prediction of moisture protection requirements for foods. *Cereal Foods World* 26:335-343.

Labuza, T.P., K. Acott, S.R.Tatini, R.Y. Lee, J. Flink, and W. McCall. 1976. Water activity determination: A collaborative study of

different methods. *Journal of Food Science* 41:910-917.

Marcolli, C., and Th. Peter. 2005. Water activity in polyol/water systems: new UNIFAC parameterization. *Atmospheric Chemistry and Physics* 5:1545-1555.

Ninni, L., M.S. Camargo, and A.J.A. Meirelles. 2000. Water activity in polyol systems. *Journal of Chemical and Engineering Data* 45:654-660.

Prior, B.A. 1979. Measurement of water activity in foods: A review. *Journal of Food Protection* 42:668-674.

Rahman, M.S. and S.S. Sablani. 2001. Measurement of water activity by electronic sensors. P. A2.5.1-A2.5.4 In R.E. Wrolstad (ed.) *Current Protocols In Food Analytical Chemistry*. John Wiley & Sons, Inc., New York.

Rahman, M.S., S.S. Sablani, N. Guizani, T.P. Labuza, and P.P. Lewicki. 2001. Direct manometric determination of vapor pressure. P. A2.4.1-A2.4.6. In R.E. Wrolstad (ed.) *Current Protocols In Food Analytical Chemistry*. John Wiley & Sons, Inc., New York.

Reid, D.S., A.J. Fontana, M.S. Rahman, S.S. Sablani, T.P. Labuza, N. Guizani, and P.P. Lewicki. 2001. Vapor pressure measurements of water p. A2.1.1-A2.5.4. In R.E. Wrolstad (ed.) *Current Protocols In Food Analytical Chemistry*. John Wiley & Sons, Inc., New York.

Reid, D.S. 1976. Water activity concepts in intermediate moisture foods. p. 54-65. In R. Davies, G.G. Birch, and K.J. Parker (ed.) *Intermediate Moisture Foods*. Applied Science Publishers, London.

Richard, J., and T.P. Labuza. 1990. Rapid determination of the water activity of some reference solutions, culture media and cheese using a dew point method. *Sci. des Aliments* 10:57-64.

Roa, V., and M.S. Tapia de Daza. 1991. Evaluation of water activity measurements with a dew point electronic humidity meter. *Lebensm*

Wiss Technol 24:208-213.

Rodel, W. 2001. Water activity and its measurement in food. P. 453-483. In E. Kress-Rogers, and C.B. Brimelow (ed.) Instrumentation and sensors for the food industry. CRC Press LLC, Boca Raton, FL.

Roos, K.D. 1975. Estimation of water activity in intermediate moisture foods. Food Tech 29:26-30.

Scott, V.N., and D.T. Bernard. 1983. Influence of temperature on the measurement of water activity of food and salt systems. Journal of Food Science 48:552-554.

Snavely, M.J., J.C. Price, and H.W. Jun. 1990. A comparison of three equilibrium relative humidity measuring devices. Drug Dev. Ind. Pharm. 16:1399-1409.

Stamp, J.A., S. Linscott, C. Lomauro, and T.P. Labuza. 1984. Measurement of water activity of salt solutions and foods by several electronic methods as compared to direct vapor pressure measurement. Journal of Food Science 49:1139-1142.

Stoloff, L. 1978. Calibration of water activity measuring instruments and devices: Collaborative study. Journal of the Association of Official Analytical Chemists 61:1166-1178.

Troller, J.A. 1983. Methods to measure water activity. Journal of Food Protection 46:129-134.

Troller, J.A., and J.H.B Christian. 1978. Water Activity and Food. Academic Press, New York.

Troller, J.A., and V.N. Scott. 1992. Measurement of water activity (a_w) and acidity. p. 135-151. In C. Vanderzant, and D.F. Splittstoesser (ed.) Compendium of Methods for the Microbiological Examination of Foods. American Public Health Association, Washington, D.C.

Van den Berg, C. 1986. Water activity. p. 11-36. In D. MacCarthy (ed.) Concentration and drying of foods. Elsevier Applied Science Publishers, London.

Van den Berg, C. 1991. Food-water relations: Progress and integration, comments and thoughts. In H. Levine, and L. Slade (ed.) Water Relationships in Foods. Plenum Press, New York.

Van den Berg, C., and S. Bruin. 1981. Water activity and its estimation in food systems: Theoretical aspects. p. 1-61. In L.B. Rockland, and G.F. Stewart (ed.) Water Activity: Influences on Food Quality. Academic Press, New York.

Vega-Mercado, H., and G.V. Barbosa-Canovas. 1994. Prediction of water activity in food systems: A review on theoretical models. Revista Espanola De Ciencia Y Tecnologia De Alimentos 34:368-388.

Vega-Mercado, H., B. Romanach, and G.V. Barbosa-Canovas. 1994. Prediction of water activity in food systems: A computer program for predicting water activity in multicomponent foods. Revista Espanola De Ciencia Y Tecnologia De Alimentos 34:427-440.

Vos, P.T., and T.P. Labuza. 1974. Technique for measurements of water activity in the high a_w range. J. Agric. Food Chem. 22:326-327.

Voysey, P. 1993. An evaluation of the AquaLab CX-2 system for measuring water activity. F. M. B. R. A. Digest No. 124 24-25.

Food Safety and Microbiology

Bei, Z.H., and R.-M.J. Nout. 2000. Effects of temperature, water activity and gas atmosphere on mycelial growth of tempe fungi *Rhizopus microsporus* var. *microsporus* and *R. microsporus* var. *oligosporus*. World Journal of Microbiology and Biotechnology 16:853-858.

Beuchat, L.R. 1981. Microbial stability as affected by water activity.

Cereal Foods World 26:345-349.

Brandt, L. 1996. Bound for success. Controlling water activity gives technologists the edge in developing safe, shelf-stable foods. *Food Formulating* 2:41-48.

Chirife, J., and M.P. Buera. 1994. Water activity, glass transition and microbial stability in concentrated/semimoist food systems. *Journal of Food Science* 59:921-927.

Chirife, J., and M.P. Buera. 1995. A critical review of some non equilibrium situations and glass transitions on water activity values of foods in the microbiological growth range. *Journal of Food Engineering* 25:531-552.

Chirife, J., and M.P. Buera. 1996. Water activity, water glass dynamics, and the control of microbiological growth in foods. *Critical Rev. in Food Sci. Nutr.* 36:465-513.

Farber, J.M., F. Coates, and E. Daley. 1992. Minimum water activity requirements for the growth of *Listeria monocytogenes*. *Lett Appl Microbiol* 15:103-105.

Franks, F. 1991. Water activity: a credible measure of food safety and quality? *Trends Food Sci Technol* March:68-72.

Garcia de Fernando, G.D., O. Diaz, M. Fernandez, and J.A. Ordonez. 1992. Changes in water activity of selected solid culture media throughout incubation. *Food Microbiology* 9:77-82.

Gibson, A.M., J. Baranyi, J.I. Pitt, M.J. Eyles, and T.A. Roberts. 1994. Predicting fungal growth: The effect of water activity on *Aspergillus flavus* and related species. *International Journal of Food Microbiology* 23:419-431.

Goaleni, N., J.E. Smith, J. Lacey, and G. Gettinby. 1997. Effects of temperature, water activity, and incubation time on production of aflatoxins and cyclopiazonic acid by an isolate of *Aspergillus flavus*

in surface agar culture. *Appl Environ Microbiol* 63:1048-1053.

Hardman, T.M. 1988. *Water and food quality*. Elsevier Press, London.

Hocking, A.D., and B.F. Miscamble. 1995. Water relations of some Zygomycetes isolated from food. *Mycological Research* 99:1113-1118.

Hocking, A.D., B.F. Miscamble, and J.I. Pitt. 1994. Water relations of *Alternaria alternata*, *Cladosporium cladosporioides*, *Cladosporium sphaerospermum*, *Curvularia lunata* and *Curvularia pallescens*. *Mycological Research* 98:91-94.

Houtsma, P.C., A. Heuvelink, J. Dufrenne, and S. Notermans. 1994. Effect of sodium lactate on toxin production, spore germination and heat resistance of proteolytic *Clostridium botulinum* strains. *Journal of Food Protection* 57:327-330.

Kress-Rogers, E. 1993. Food quality measurement. *Food Industry News* September:23-26.

Kuntz, L.A. 1992. Keeping microorganisms in control. *Food Product Design* August:44-51.

Levine, H., and L. Slade. 1991. *Water Relationships in Foods*. Plenum Press, New York.

Li, K.Y., and J.A. Torres. 1993. Water activity relationships for selected mesophiles and psychrotrophs at refrigeration temperature. *Journal of Food Protection* 56:612-615.

Lopez-Malo, A., S. Guerrero, and S.M. Alzamora. 2000. Probabilistic modeling of *Saccharomyces cerevisiae* inhibition under the effects of water activity, pH, and potassium sorbate concentration. *Journal of Food Protection* 63:91-95.

Mannheim, C.H., J.X. Liu, and S.G. Gilbert. 1994. Control of water in foods during storage. *Journal of Food Engineering* 22:509-532.

Marauska, M., A. Vigants, A. Klincare, D. Upite, E. Kaminska, and M. Bekers. 1996. Influence of water activity and medium osmolality on the growth and acid production of *Lactobacillus casei* var. *alactosus*. Proceedings of the Latvian Academy of Sciences Section B Natural Exact and Applied Sciences 50:144-146.

Masana, M.O., and J. Baranyi. 2000. Growth/no growth interface of *Brochothrix thermosphacta* as a function of pH and water activity. Food Microbiology 17:485-858.

Mattick, K. L., F. Jorgensen, J.D. Legan, M.B. Cole, J. Porter, H.M. Lappin-Scott, and T.J. Humphrey. 2000. Survival and filamentation of *Salmonella enterica* serovar Enteritidis PT4 and *Salmonella enterica* serovar Typhimurium DT104 at low water activity. Appl Environ Microbiol 66:1274-1279.

Mattick, K.L., F. Jorgensen, J.D. Legan, H.M. Lappin-Scott, and T.J. Humphrey. 2000. Habituation of *Salmonella* spp. at reduced water activity and its effect on heat tolerance. Appl Environ Microbiol 66:4921-4925.

Mattick, K.L., F. Jorgensen, J.D. Legan, H.M. Lappin-Scott, and T.J. Humphrey. 2001. Improving recovery of *Salmonella enterica* Serovar Typhimurium DT104 cells injured by heating at different water activity values. Journal of Food Protection 64:1472-1476.

McMeekin, T.A., and T. Ross. 1996. Shelf life prediction: Status and future possibilities. International Journal of Food Microbiology 33:65-83.

Miller, A.J. 1992. Combined water activity and solute effects on growth and survival of *Listeria monocytogenes*. Journal of Food Protection 55:414-418.

Nakajo, M., and Y. Moriyama. 1993. Effect of pH and water activity on heat resistance of spores of *Bacillus coagulans*. Journal of the Japanese Society for Food Science and Technology 40:268-271.

Nelson, K.A., and T.P. Labuza. 1994. Water activity and food polymerscience: Implications of state on arrhenius and WLF models in predicting shelf life. *Journal of Food Engineering* 22:271-289.

Nesci, A., M. Rodrigues, and M. Etcheverry. 2003. Control of *Aspergillus* growth and aflatoxin production using antioxidants at different conditions of water activity and pH. *Journal of Applied Microbiology* 95:279-287.

Nolan, D.A., D.C. Chamblin, and J.A. Troller. 1992. Minimal water activity levels for growth and survival of *Listeria monocytogenes* and *Listeria innocua*. *International Journal of Food Microbiology* 16:323-335.

Noorlidah, A., A. Nawawi, and I. Othman. 2000. Fungal spoilage of starch-based foods in relation to its water activity (aw). *Journal of Stored Products Research* 36:47-54.

Park, C.M., and L.R. Beuchat. 2000. Survival of *Escherichia coli* O157:H7 in potato starch as affected by water activity, pH and temperature. *Lett Appl Microbiol* 31(5):364-367.

Petersson, S., and J. Schnuerer. 1995. Biocontrol of mold growth in high moisture wheat stored under airtight conditions by *Pichia anomala*, *Pichia guilliermondii*, and *Saccharomyces cerevisiae*. *Appl Environ Microbiol* 61:1027-1032.

Pitt, J.I., and B.F. Mischamble. 1995. Water relations of *Aspergillus flavus* and closely related species. *Journal of Food Protection* 58:86-90.

Plaza, P., J. Usall, N. Teixido, and I. Vinas. 2003. Effect of water activity and temperature on germination and growth of *Penicillium digitatum*, *P. italicum* and *Geotrichum candidum*. *Journal of Applied Microbiology* 94:549-554.

Quintavalla, S., and G. Parolari. 1993. Effects of temperature, water

activity and pH on the growth of *Bacillus* cells and spore: A response surface methodology study. *International Journal of Food Microbiology* 19:207-216.

Rockland, L.B., and G.F. Stewart. 1981. *Water activity: Influences on food quality*. Academic Press, New York.

Rockland, L.B., and S.K. Nishi. 1980. Influence of water activity on food product quality and stability. *Food Tech* 34:42-59.

Saad, R.R. 1992. Effect of water activity on growth and lipids of xerophilic fungi, *Aspergillus repens* and *Aspergillus amstelodami*. *Zentralblatt Fuer Mikrobiologie* 147:61-64.

Salter, M.A., D.A. Ratkowsky, T. Ross, and T.A. McMeekin. 2000. Modelling the combined temperature and salt (NaCl) limits for growth of a pathogenic *Escherichia coli* strain using nonlinear logistic regression. *International Journal of Food Microbiology* 61:159-167.

Santos, J., T.M. Lopez-Diaz, M.C. Garcia-Lopez, M.C. Garcia-Fernandez, and A. Otero. 1994. Minimum water activity for the growth of *Aeromonas hydrophila* as affected by strain, temperature and humectant. *Lett Appl Microbiol* 19:76-78.

Sautour, M., A. Rouget, P. Dantigny, C. Divies, and M. Bennisoussan. 2001. Prediction of conidial germination of *Penicillium chrysogenum* as influenced by temperature, water activity and pH. *Lett Appl Microbiol* 32:131-134.

Seow, C.C., T.T. Teng, and C.H. Quah. 1988. *Food preservation by moisture control*. Elsevier, New York.

Shebuski, J.R., O. Vilhelmsson, and K.J. Miller. 2000. Effects of growth at low water activity on the thermal tolerance of *Staphylococcus aureus*. *Journal of Food Protection* 63:1277-1281.

Taoukis, P., W. Breene, and T.P. Labuza. 1988. Intermediate moisture foods. *Adv Cereal Sci Technol* 9:91-128.

Tapia de Daza, M.S., Y. Villegas, and A. Martinez. 1991. Minimal water activity for growth of *Listeria monocytogenes* as affected by solute and temperature. *International Journal of Food Microbiology* 14:333-337.

Tokuoka, K., and T. Ishitani. 1991. Minimum water activities for the growth of yeasts isolated from high sugar foods. *Journal of General and Applied Microbiology* 37:111-119.

Torres, R., J. Usall, N. Teixido, M. Abadias, and I. Vinas. 2003. Liquid formulation of the biocontrol agent *Candida sake* by modifying water activity or adding protectants. *Journal of Applied Microbiology* 94:330-339.

Ucar, F., and I. Guneri. 1996. The effect of water activity, pH and temperature on the growth of osmophilic yeasts. *Turkish Journal of Biology* 20:37-46.

Wijtzes, T., P.J. McClure, M.H. Zwietering, and T.A. Roberts. 1993. Modelling bacterial growth of *Listeria monocytogenes* as a function of water activity, pH and temperature. *International Journal of Food Microbiology* 18:139-149.

Zwietering, M.H., T. Wijtzes, J.C. de Wit, and K. Van'T Riet. 1992. A decision support system for prediction of the microbial spoilage in foods. *Journal of Food Protection* 55:973-979.

Meat and Seafood

Allen, K., D. Cornforth, D. Whittier, M. Vasavada, and B. Nummer. 2007. Evaluation of high humidity and wet marinade methods for pasteurization of jerky. *Journal of Food Science*. 72:C351-C355.

Chen, H.C. 1995. Seafood microorganisms and seafood safety. *Journal of Food and Drug Analysis* 3:133-144.

Clavero, M.R.S., and L.R. Beuchat. 1996. Survival of *Escherichia*

coli O157:H7 in broth and processed salami as influenced by pH, water activity, and temperature and suitability of media for its recovery. *Appl Environ Microbiol* 62:2735-2740.

Duffy, L.L., P.B. Vanderlinde, and F.H. Grau. 1994. Growth of *Listeria monocytogenes* on vacuum-packed cooked meats: Effects of pH, a_w , nitrite and ascorbate. *International Journal of Food Microbiology* 23:377-390.

Elgasim, E.A., and M.S. Al Wesali. 2000. Water activity and Hunter colour values of beef patties extended with samh (*Mesembryanthemum forsskaei* Hochst) flour. *Food Chem* 69(2):181-185.

Gmez, R., and J. Fernandez-Salguero. 1993. Note: Water activity of Spanish intermediate moisture fish products. *Revista Espanola De Ciencia Y Tecnologia De Alimentos* 33:651-656.

Hand, L. 1994. Controlling water activity and pH in snack sticks. *Meat Marketing and Technology* May:55-56.

Lee, M.B., and S. Styliadis. 1996. A survey of pH and water activity levels in processed salamis and sausages in Metro Toronto. *Journal of Food Protection* 59:1007-1010.

Luecke, F.K. 1994. Fermented meat products. *Food Res Intl* 27:299-307. Minegishi, Y., Y. Tsukamasa, K. Miake, T. Shimasaki, C. Imai, M.

Sugiyama, and H. Shinano. 1995. Water activity and microflora in commercial vacuum-packed smoked salmons. *Journal of the Food Hygienic Society of Japan* 36:442-446.

Nunez, F., M.C. Diaz, M. Rodriguez, E. Aranda, A. Martin, and M.A. Asensio. 2000. Effects of substrate, water activity, and temperature on growth and verrucosidin production by *Penicillium polonicum* isolated from dry-cured ham. *Journal of Food Protection* 63:231-236.

Placido, M. and M.P. Aleman. 2002. Rapid hygrometric method

for determining water activity. *Ciencia y Tecnologia Alimentaria* 3(4):229-235.

Rocha-Garza, A.E., and J.F. Zayas. 1996. Quality of broiled beef patties supplemented with wheat germ protein flour. *Journal of Food Science* 61:418-421

Sabadini, E., M.D. Hubinger, P. J. D.Sobral, and B.C. Carvalho, Jr. 2001. Change of water activity and meat colour in the elaboration process of dehydrated salted meat. *Ciencia e Tecnologia de Alimentos* 21(1):14-19.

Shimasaki, T., K. Miake, Y. Tsukamasa, M.A. Sugiyama, Y. Minegishi, and H. Shinano. 1994. Effect of water activity and storage temperature on the quality and microflora of smoked salmon. *Nippon Suisan Gakkaishi* 60:569-576.

Untermann, F., and C. Muller. 1992. Influence of a_w value and storage temperature on the multiplication and enterotoxin formation of staphylococci in dry-cured raw hams. *International Journal of Food Microbiology* 16:109-115.

Williams, S.K., G.E. Rodrick, and R.L. West. 1995. Sodium lactate affects shelf life and consumer acceptance of fresh Catfish (*Ictalurus nebulosus*, *marmoratus*) fillets under simulated retail conditions. *Journal of Food Science* 60:636-639.

Dairy Products

Clavero, M.R.S., and L.R. Beuchat. 1996. Survival of *Escherichia coli* O157:H7 in broth and processed salami as influenced by pH, water activity, and temperature and suitability of media for its recovery. *Appl Environ Microbiol* 62:2735-2740.

Correia, R., M. Magalhaes, M. Pedrini, A. da Cruz, and I. Clementino. 2008. Ice cream made from cow and goat milk: chemical composition and melting point characteristics. *Revista Ciencia Agronomica* 39:251-256.

Duffy, L.L., P.B.Vanderlinde, and F.H. Grau. 1994. Growth of *Listeria monocytogenes* on vacuum-packed cooked meats: Effects of pH, a_w , nitrite and ascorbate. *International Journal of Food Microbiology* 23:377-390.

Gmez, R., and J. Fernandez-Salguero. 1993. Note: Water activity of Spanish intermediate moisture fish products. *Revista Espanola De Ciencia Y Tecnologia De Alimentos* 33:651-656.

Hand, L. 1994. Controlling water activity and pH in snack sticks. *Meat Marketing and Technology* May:55-56.

Hardy, J., J. Scher, and S. Banon. 2002. Water activity and hydration of dairy powders. *Lait* 82:441-442.

Lee, M.B., and S. Styliadis. 1996. A survey of pH and water activity levels in processed salamis and sausages in Metro Toronto. *Journal of Food Protection* 59:1007-1010.

Luecke, F.K. 1994. Fermented meat products. *Food Res Intl* 27:299-307.

Malec, L.S., A.S. Pereyra-Gonzales, G.B. Naranjo, and M.S. Vigo. 2002. Influence of water activity and storage temperature on lysine availability of a milk like system. *Food Res Intl* 35(9):849-853.

Minegishi, Y., Y. Tsukamasa, K. Miake, T. Shimasaki, C. Imai, M. Sugiyama, and H. Shinano. 1995. Water activity and microflora in commercial vacuum-packed smoked salmons. *Journal of the Food Hygienic Society of Japan* 36:442-446.

Rocha-Garza, A.E., and J.F. Zayas. 1996. Quality of broiled beef patties supplemented with wheat germ protein flour. *Journal of Food Science* 61:418-421.

Shah, N.P., and R.R. Ravula. 2000. Influence of water activity on fermentation, organic acids production and viability of yoghurt and

probiotic bacteria. *Australian Journal of Dairy Technology* 55(3):127-131.

Shimasaki, T., K. Miake, Y. Tsukamasa, M.A. Sugiyama, Y. Minegishi, and H. Shinano. 1994. Effect of water activity and storage temperature on the quality and microflora of smoked salmon. *Nippon Suisan Gakkaishi* 60:569-576.

Untermann, F., and C. Muller. 1992. Influence of a_w value and storage temperature on the multiplication and enterotoxin formation of staphylococci in dry-cured raw hams. *International Journal of Food Microbiology* 16:109-115.

Williams, S.K., G.E. Rodrick, and R.L. West. 1995. Sodium lactate affects shelf life and consumer acceptance of fresh Catfish (*Ictalurus nebulosus*, *marmoratus*) filets under simulated retail conditions. *Journal of Food Science* 60:636-639.

Fruits and Vegetables

Ayub, M., R. Khan, S. Wahab, A. Zeb, and J. Muhammad. 1995. Effect of crystalline sweeteners on the water activity and shelf stability of osmotically dehydrated guava. *Sarhad Journal of Agriculture* 11:755-761.

Beveridge, T., and S.E. Weintraub. 1995. Effect of blanching pretreatment on color and texture of apple slices at various water activities. *Food Res Intl* 28:83-86.

Clavero, M.R.S., R.E. Brackett, L.R. Beuchat, and M.P. Doyle. 2000. Influence of water activity and storage conditions on survival and growth of proteolytic *Clostridium botulinum* in peanut spread. *Food Microbiology* 17(1):53-61.

Fouskaki, M., K. Karametsi, and N.A. Chaniotakis. 2003. Method for the determination of water content in sultana raisins using a water activity probe. *Food Chem* 82:133-1337.

Gogus, F., C. Cuzdemir, and S. Eren. 2000. Effects of some hydrocolloids and water activity on nonenzymic browning of concentrated orange juice. *Nahrung* 44(6):438-442.

Hubinger, M., F.C. Menegalli, R.J. Aguerre, and C. Suarez. 1992. Water vapor adsorption isotherms of guava, mango and pineapple. *Journal of Food Science* 57:1405-1407.

Jimenez, M., M. Manez, and E. Hernandez. 1996. Influence of water activity and temperature on the production of zearalenone in corn by three *Fusarium* species. *International Journal of Food Microbiology* 29:417-421.

Khalloufi, S., J. Giasson, and C. Ratti. 2000. Water activity of freeze dried mushrooms and berries. *Canadian Agricultural Engineering* 42(1):51-56.

Kiranoudis, C.T., Z.B. Maroulis, E. Tsami, and D. Marinos-Kouris. 1993. Equilibrium moisture content and heat of desorption of some vegetables. *Journal of Food Engineering* 20:55-74.

Lopez-Malo, A., and E. Palou. 2000. Modeling the growth/nogrowth interface of *Zygosaccharomyces bailii* in Mango puree. *Journal of Food Science*: 65:516-520.

Makower, B., and S. Myers. 1943. A new method for the determination of moisture in dehydrated vegetables. *Proceedings of Institute of Food Technologists, 4th Conference* 156.

Maltini, E., D. Torreggiani, B.R. Brovotto, and G. Bertolo. 1993. Functional properties of reduced moisture fruits as ingredients in food systems. *Food Res Intl* 26:413-419.

Marin, S., N. Magan, M. Abellana, R. Canela, A.J. Ramos, and V. Sanchis. 2000. Selective effect of propionates and water activity on maize mycoflora and impact on fumonisin B1 accumulation. *Journal of Stored Products Research* 36:203-214.

- Marin, S., V. Sanchis, I. Vinas, R. Canela, and N. Magan. 1995. Effect of water activity and temperature on growth and fumonisin B-1 and B-2 production by *Fusarium proliferatum* and *F. moniliforme* on maize grain. *Lett Appl Microbiol* 21:298-301.
- Monsalve-Gonzalez, A., G.V. Barbosa-Canovas, and R.P. Cavalieri. 1993. Mass transfer and textural changes during processing of apples by combined methods. *Journal of Food Science* 58:1118-1124.
- Pinsirodom, P., and K.L. Parkin. 2000. Selectivity of Celite immobilized patatin (lipid acyl hydrolase) from potato (*Solanum tuberosum* L.) tubers in esterification reactions as influenced by water activity and glycerol analogues as alcohol acceptors. *J. Agric. Food Chem.* 48(2):155-160.
- Tapia de Daza, M.S., C.E. Aguilar, V. Roa, and R.V. Diaz de Tablante. 1995. Combined stress effects on growth of *Zygosaccharomyces rouxii* from an intermediate moisture papaya product. *Journal of Food Science* 60:356-359.
- Zeb, A., R. Khan, A. Khan, M. Saeed, and S.A. Manan. 1994. Influence of crystalline sucrose and chemical preservatives on the water activity and shelf stability of intermediate banana chips. *Sarhad Journal of Agriculture* 10:721-726.
- Zhang, X.W., X. Liu, D.X. Gu, W. Zhou, R.L. Wang, and P. Liu. 1996. Desorption isotherms of some vegetables. *Journal of the Science of Food and Agriculture* 70:303-306.

Baked Goods and Cereals

- Abellana, M., A.J. Ramos, V. Sanchis, and P.V. Nielsen. 2000. Effect of modified atmosphere packaging and water activity on growth of *Eurotium amstelodami*, *E. chevalieri* and *E. herbariorum* on a sponge cake analogue. *Journal of Applied Microbiology* 88:606-616.
- Aramouni, F.M., K.K. Kone, J.A. Craig, and D.Y.C. Fung. 1994. Growth of *Clostridium sporogenes* PA 3679 in home-style canned

quick breads. *Journal of Food Protection* 57:882-886.

Cahagnier, B., L. Lesage, and D. Richard-Molard. 1993. Mould growth and conidiation in cereal grains as affected by water activity and temperature. *Lett Appl Microbiol* 17:7-13.

Clawson, A.R., and A.J. Taylor. 1993. Chemical changes during cooking of wheat. *Food Chem* 47:337-343.

Fleurat-Lessard, F. 2002. Qualitative reasoning and integrated management of the quality of stored grain: a promising new approach. *Journal of Stored Products Research* 38:191-218.

Gmez, R., J. Fernandez-Salguero, M.A. Carmona, and D. Sanchez. 1993. Water activity in foods with intermediate moisture levels: Bakery and confectionery products: Miscellany. *Alimentaria* 30:55-57.

Guynot, M.E., A.J. Ramos, L. Seto, P. Purroy, V. Sanchis, and S. Marin. 2003. Antifungal activity of volatile compounds generated by essential oils against fungi commonly causing deterioration of bakery products.

Harris, M., and M. Peleg. 1996. Patterns of textural changes in brittle cellular cereal foods caused by moisture sorption. *Cereal Chem* 73:225-231.

Hope, R., and N. Magan. 2003. Two-dimensional environmental profiles of growth, deoxynivalenol and nivalenol production by *Fusarium culmorum* on wheat-based substrate. *Lett Appl Microbiol* 37:70-74.

Michniewicz, J., C.G. Biliaderis, and W. Bushuk. 1992. Effect of added pentosans on some properties of wheat bread. *Food Chem* 43:251-257.

Moreno-Contreras, M.D., A.J. Martinez-Yepe, and R.R. Martinez. 2000. Determination of deoxynivalenol (DON) in wheat, barley and corn and its relationship with the levels of total molds, *Fusarium* spp., infestation percentage, and water activity. *Archivos Latinoameri-*

canos de Mutricion. 50(2):183-186.

Phoungchandang, S., and J.L. Woods. 2000. Moisture diffusion and desorption isotherms for banana. *Journal of Food Science* 65:651-657.

Ramanathan, S., and S. Cenkowski. 1995. Sorption isotherms of flour and flow behaviour of dough as influenced by flour compaction. *Canadian Agricultural Engineering* 37:119-124.

Roessler, P.F., and M.C. Ballenger. 1996. Contamination of an un-preserved semisoft baked cookie with a Xerophilic *Aspergillus* species. *Journal of Food Protection* 59:1055-1060.

Schebor, C., and J. Chirife. 2000. A survey of water activity and pH values in fresh pasta packed under modified atmosphere manufactured in Argentina and Uruguay. *Journal of Food Protection* 63:965-969.

Seiler, D.A.L. 1979. The mould-free shelf life of bakery products. *FMBRA Bulletin* April:71-74.

Sumner, S.S., J.A. Albrecht, and D.L. Peters. 1993. Occurrence of enterotoxigenic strains of *Staphylococcus aureus* and enterotoxin production in bakery products. *Journal of Food Protection* 56:722-724.

Tesch, R., M.D. Normand, and M. Peleg. 1996. Comparison of the acoustic and mechanical signatures of two cellular crunchy cereal foods at various water activity levels. *Journal of the Science of Food and Agriculture* 70:347-354.

Weegels, P.L., J.A. Verhoek, A.M.G. de Groot, and R.J. Hamer. 1994. Effects of gluten of heating at different moisture contents: I. Changes in functional properties. *Journal of Cereal Science* 19:31-38.

Beverages, Soups, Sauces, and Preserves

Cardelli, C., and T.P. Labuza. 2001. Application of Weibull Hazard

Analysis to the determination of shelf life of roasted and ground coffee. *Lebensm Wiss Technol* 34:273-278.

Carson, K.J., J.L. Collins, and M.P. Penfield. 1994. Unrefined, dried apple pomace as a potential food ingredient. *Journal of Food Science* 59:1213-1215.

Cavia, M.M., M.A. Fernandez-Muio, J.F. Huidobro, and M.T. Sancho. 2004. Correlation between Moisture and Water Activity of Honeys Harvested in Different Years. *Journal of Food Science* 69:C-368-370.

Durrani, M.J., R. Khan, M. Saeed, and A. Khan. 1992. Development of concentrated beverages from Anna apples with or without added preservatives by controlling activity of water for shelf stability. *Sarhad Journal of Agriculture* 8:23-28.

Ferragut, V., J.A. Salazar, and A. Chiralt. 1993. Stability in the conservation of emulsified sauces low in oil content. *Alimentaria* 30:67-69.

Gleiter, R.A., H. Horn, and H.D. Isengard. 2006. Influence of type and state of crystallization on the water activity of honey. *Food Chem* 96:441-445.

Hajmeer, M.N., F.M. Aramouni, and E.A.E.Boyle. 2000. Shelf-life of lite syrup after opening and storage at room or refrigerated temperature. *Journal of Food Quality* 23:529-540.

Ibarz, A., J. Pagan, and R. Miguelsanz. 1992. Rheology of clarified fruit juices: II. Blackcurrant juices. *Journal of Food Engineering* 15:63-74.

Khalloufi, S., Y. El-Maslouhi, and C. Ratti. 2000. Mathematical model for prediction of glass transition temperature of fruit powders. *Journal of Food Science* 65:842-848.

Kusumegi, K., T. Takahashi, and M. Miyagi. 1996. Effects of

addition of sodium citrate on the pasteurizing conditions in Tuyu, Japanese noodle soup. *Journal of the Japanese Society for Food Science and Technology* 43:740-747.

Perera, C.O. 2005. Selected quality attributes of dried foods. *Drying Technology* 23:717-730.

Sa, M.M., and A.M. Sereno. 1993. Effect of temperature on sorption isotherms and heats of sorption of quince jam. *International Journal of Food Science & Technology* 28:241-248.

Shafi ur-Rahman, M. 2005. Dried food properties: challenges ahead. *Drying Technology* 23:695-715.

Pharmaceuticals/Cosmetics

Ahlneck, C., and G. Zografi. 1990. The Molecular basis of moisture effects on the physical and chemical stability of drugs in the solid state. *International Journal of Pharmaceutics* 62:87-95.

Bell, L.N., and K.L. White. 2000. Thiamin Stability in Solids as Affected by the Glass Transition. *Journal of Food Science* 65:498-501.

Cochet, N., and A.L. Demain. 1996. Effect of water activity on production of betalactam antibiotics by *Streptomyces clavuligerus* in submerged culture. *Journal of Applied Bacteriology* 80:333-337.

Constantino, H.R., R. Langer, and A.M. Klivanov. 1994. Solid-Phase Aggregation of Proteins under Pharmaceutically Relevant Conditions. *Journal of Pharmaceutical Science* 83:1662-1669.

Enigl, D.C. 2001. Pharmaceutical stability testing using water activity. *European Pharmaceutical Review* 6:46-49.

Enigl, D.C., and K.M. Sorrel. 1997. Water Activity and Self-Preserving Formulas. p. 45-73. In J.J. Kabara, and D.S. Orth (ed.) *Preservative-Free and Self-Preserving Cosmetics and Drugs: Principles and Prac-*

tice. Marcel Dekker.

Hageman, M.J. 1988. The Role of Moisture in Protein Stability. *Drug Dev. Ind. Pharm.* 14:2047-2070.

Heidemann, D.R., and P.J. Jarosz. 1991. Preformulation Studies Involving Moisture Uptake in Solid Dosage Forms. *Pharmaceutical Research* 8:292-297.

Kontny, M.J. 1988. Distribution of Water in Solid Pharmaceutical Systems. *Drug Dev. Ind. Pharm.* 14:1991-2027.

Sablani, S.S., K. Al-Belushi, I. Al-Marhubi, and R. Al-Belushi. 2007. Evaluating Stability of Vitamin C in Fortified Formula Using Water Activity and Glass Transition. *International Journal of Food Properties* 10:61-71.

Zografi, G. 1988. States of Water Associated with Solids. *Drug Dev. Ind. Pharm.* 14:1905-1926.

Zografi, G., and M.J. Kontny. 1986. The interactions of water with cellulose and starch derived pharmaceutical excipients. *Pharmaceutical Research* 3:187-193.

Miscellaneous

Bell, L.N. 1995. Kinetics of non-enzymatic browning in amorphous solid systems: Distinguishing the effects of water activity and the glass transition. *Food Res Intl* 28:591-597.

Bell, L.N., and T.P. Labuza. 1992. Compositional influence on the pH of reduced-moisture solutions. *Journal of Food Science* 57:732-734.

Bell, L.N., and T.P. Labuza. 1994. Influence of the low-moisture state on pH and its implication for reaction kinetics. *Journal of Food Engineering* 22:291-312.

Bhandari, B., and I. Bareyre, 2003. Estimation of crystalline phase present in glucose crystal solution mixture by water activity measurement. *Lebensm Wiss Technol* 36:729-733(5).

Brake, N.C., and O.R. Fennema. 1993. Edible coatings to inhibit lipid migration in a confectionery product. *Journal of Food Science* 58:1422-1425.

Dole, M., and L. Faller. 1950. Water sorption by synthetic high polymers. *Journal of the American Chemical Society* 12:414-419.

Fernandez-Salguero, J., R. Gmez, and M.A. Carmona. 1993. Water activity in selected high moisture foods. *Journal of Food Composition and Analysis* 6:364-369.

Juhan, K., and G.K. Byung. 2000. Lipase-catalyzed synthesis of lysophosphatidylcholine using organic cosolvent for in situ water activity control. *Journal of American Oil Chemists' Society* 77(7):701-797.

Lima, J.R., S.D.S. Campos, and L. A.G. Goncalves. 2000. Relationship between water activity and texture of roasted and salted cashew kernel. *Journal of Food Science and Technology* 37(5):512-513.

Lomauro, C.J., A.S. Bakshi, and T.P.Labuza. 1985a. Evaluation of food moisture sorption isotherm equations. Part II: Milk, coffee, tea, nuts, oilseeds, spices and starchy foods. *Lebensm Wiss Technol* 18:118-124.

Lomauro, C.J., A.S. Bakshi, and T.P. Labuza. 1985b. Evaluation of food moisture sorption isotherm equations. Part I: Fruit, vegetable and meat products. *Lebensm Wiss Technol* 18:111-117.

14 Appendix A

14.1 Preparing Salt Solution

If you choose to mix a saturated salt solution for use as a verification standard, we recommend that you use the approved AOAC method.

Steps 1 through 4 detail the AOAC method.

1. Select a reagent grade salt and place it in a test container to a depth of about 4 cm for more soluble salts (lower a_w), to a depth of about 1.5 cm for less soluble salts (high a_w), and to an intermediate depth for intermediate salts.
2. Add distilled water in increments of about 2 ml, stirring constantly.
3. Add water until the salt can absorb no more water, evidenced by the presence of free liquid. Keep the amount of free liquid to the minimum needed to keep the solution saturated with water. If you plan on using this solution over a long term period, seal the solution well to prevent losses from evaporation. Table 4 shows saturated salt solutions and their respective water activities at various temperatures. Please note that these values are based on averaged published data, and the standard errors shown reflect Greenspan's standard error for each salt solution, not the accuracy of the AquaLab measuring the salt. AquaLab measures all samples with an accuracy of $\pm 0.003 a_w$.
4. Saturated salt solutions are very temperature sensitive and their values are not as accurate as the verification standards offered by Decagon.

Table 4: Water Activity of Selected Salt Solutions

Saturated Solution	a_w at 20 °C	a_w at 25 °C
Lithium Chloride	0.113 \pm 0.003	0.113 \pm 0.003
Magnesium Chloride	0.331 \pm 0.002	0.328 \pm 0.002
Potassium Carbonate	0.432 \pm 0.003	0.432 \pm 0.004
Magnesium Nitrate	0.544 \pm 0.002	0.529 \pm 0.002
Sodium Chloride	0.755 \pm 0.001	0.753 \pm 0.001
Potassium Chloride	0.851 \pm 0.003	0.843 \pm 0.003
Potassium Sulfate	0.976 \pm 0.005	0.973 \pm 0.005

Note: Table 4 adapted from Greenspan (1977). Rounded to nearest thousandth.

15 Appendix B

Temperature Correction of Decagon's Verification Standards

Table 5: Water Activity of Selected Salt Solutions

Temp. (°C)	H ₂ O	0.50 mol/kg KCL	2.33 mol/kg NaCL	6.00 mol/kg NaCL	8.57 mol/kg LiCl	13.41 mol/kg LiCl
15.0	1.000	0.984	0.923	0.761	0.492	0.238
20.0	1.000	0.984	0.922	0.760	0.496	0.245
25.0	1.000	0.984	0.920	0.760	0.500	0.250
30.0	1.000	0.984	0.920	0.760	0.504	0.255
35.0	1.000	0.984	0.920	0.760	0.508	0.261
40.0	1.000	0.984	0.921	0.760	0.512	0.266
50.0	1.000	0.984	0.894	0.740	0.517	0.275

Note: AquaLab measures these verification standards to $\pm 0.003 a_w$.

16 Declaration of Conformity

Application of Council Directive: 2004/108/EC and 2011/65/EU

Standards to which conformity is declared: EN 61326-1:2013 and
EN 50581:2012

Manufacturer's Name: Decagon Devices, Inc 2365 NE
Hopkins Ct. Pullman, WA 99163
USA

Type of Equipment: AquaLab water activity meter.

Model Number: Pre

Year of First Manufacture: 2012

The undersigned hereby declares on behalf of Decagon Devices, Inc. that the above referenced products, to which this declaration relates, fully conform to the provisions of the Council Directives and standards referenced above.



Michael Wadsworth
Engineering Director
7-9-2015

17 Certificate of Traceability

Decagon Devices, Inc.
2365 NE Hopkins Court
Pullman WA 99163 USA

Tel: 509-332-5601
Fax: 509-332-5158
support@AquaLab.com

This NIST statement certifies that Decagon Devices Inc. manufactures all AquaLab water activity meters according to temperature standards with calibration traceable to the National Institute of Standards and Technology (NIST).

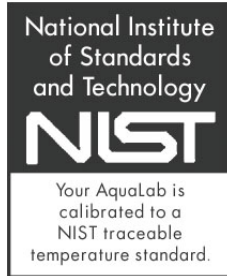

Index

- Accessories, 13
- Accuracy, 3
- AquaLab
 - and Chilled Mirror Dew Point Technique, 4
 - and Temperature, 5
 - AquaLink Software, 42
- Beeper
 - Changing, 19
- Binding, 10, 11
- Block Diagram
 - Dew Point, 22
 - Volatiles, 23
- Block Failure, 49
- Buttons
 - for Linear Offset Settings, 20
 - for Menu Selection, 16
- C for Continuous Mode, 17
- Calibration, 29
 - Standards, 29
- Capillaries, 10
- Cautions, 40, 46
- CE Compliance, 79
- Chilled-Mirror Technique, 4
- Cleaning Procedures, 24
- Coated Samples
 - Shortening Read Time for, 35
- Component Performance Indicator, 50
- Components, 13
- Computer Interface, 42
- Condensation, 9
- Contact Information, 1
- Cosmetics, 7, 12
- Customer Support, 1
- Czech, 16
- Danish, 16
- DecaTerm Program, 43
- Declaration of Conformity, 79
- Dehydrated Samples, 36
- Dried Samples
 - Shortening Read Time for, 35
- Dry Samples, 41, 48
- DUO, 12
- Email, 1, 80
- Equilibrium, 8
- Error Messages, 45
 - “Sample too Hot”, 47
 - “Sample too Dry”, 48
 - Triangle on Screen, 49
- Exit, 20
- Fan
 - Inside Sample Chamber, 5
- Fax, 80
- Features, 14
- French, 16
- Fuse
 - Changing, 45
- German, 16
- Gibbs Free Energy, 9
- Homogeneous, 10, 34
- Humidity, Related to a_w , 4
- Hyperterminal, 43
- Infrared Thermometer, 8
- Italian, 16

- Japanese, 16
- Languages, 16
- LED, 18
- Linear Offset
 - Causes for, 28
 - Definition, 28
 - How to Adjust for, 29
 - Menu, 20
 - When to Verify for, 29
- Liquid Phase, 7
- Location
 - For Sampling, 14
- Loss on Drying, 7
- Low Water Activity, 37, 41
- Main Menu, 16
- Maintenance, 22
- Matrix, 10
- Menus
 - System Configuration, 19
- Microbial Growth, 12
- Model 4TEV, 37
- Multi-Component Food, 8
- NIST Traceability, 80
- Norwegian, 16
- Osmotic, 10
- Peltier Cooler, 4
- Perishability, 7
- Pharmaceuticals, 7, 12
- Polish, 16
- Portuguese, 16
- Preparing Salt Solutions, 76
- Pressure Effects, 10
- Propylene Glycol, 5, 37, 46
 - Cleaning Out the Chamber, 37
- Quantitative Analysis, 7
- Read Time
 - Affected by Sample Temperature, 38
 - Long Read Time, 6, 35, 46
- Readings
 - Cautions, 40
 - How AquaLab Takes, 40
- References, 54
 - Baked Goods and Cereals, 69
 - Beverages, Soups, Sauces, Preserves, 71
 - Dairy Products, 65
 - Food Safety and Microbiology, 57
 - Fruits and Vegetables, 67
 - Meat and Seafood, 63
 - Miscellaneous, 74
 - Pharmaceuticals/Cosmetics, 73
 - Water Activity Theory & Measurement, 54
- Regulations, 7
- Repair Instructions, 52
- Safety Data Sheet, 29
- Salt Standard, 29
- Sample
 - Slow Water-Emitting, 46
- Sample Equilibration Screen, 6
- Samples
 - Coated, 35
 - Dehydrated, 36
 - Dried, 35
 - Low Water Activity, 37
 - Needing Special Preparation, 35
 - Not at Room Temperature, 38

- Slow Water-Emitting, 36
- Surface Area of, 36
- Viscous, 36
- Sampling Mode
 - Continuous, 17
 - Normal, 17
- Saturated Salts, 76
- Saturation, 8
- Seller's Liability, 2
- Sorption Isotherm, 11
- Spanish, 16
- Specifications, 3
- Spilling the Sample, 40
- Swedish, 16

- Technical Difficulties, 45
- Technical Support, 1
- Telephone Number, 1
- Temperature
 - Effects, 9
 - Hot Samples, 40
 - of Instrument, 41
 - Sample not at Room Temperature, 40
 - Temperature Control, 5
- Thermodynamic Property, 9
- Triangle
 - Mirror Performance Indicator, 49
- Troubleshooting, 45

- USB
 - Driver, 43
 - Interface Cable, 42

- Vapor Equilibrium, 34
- Vapor Phase, 7, 9, 34
- Verification, 30
- Verification Standards
 - Compared to Saturated Salts, 77
- Volatiles, 5, 36

- Warm-Up, 15
- Warranty, 2, 53
- Water Activity, 7
 - AquaLab and, 4
 - Definition, 4
 - Displayed, 15
- Water Content, 11
- Water Potential, 9