

BISS AC-05-XXXX Series hydraulic wedge grips are intended for both static and dynamic testing in tension, compression as well as tension-compression. Hydraulically activated wedge action ensures uniform and axially aligned gripping of both flat and round test coupons as well as to hold test fixtures.

Required equal pressure to both grips is set by means of pressure regulating valve on the service manifold. Gripping is activated from the operator touch screen panel. These grips are suitable for use on electro mechanical machines when configured along with a dedicated pump and service manifold unit. Pressure line accumulators and non-return valving ensure retention of gripping force in the event of power outage.

Side mounting design allows safe handling and easy insertion of specimen. A wide variety of wedges is available to suit practically every standard specimen geometry. Custom wedge designs can be ordered to suit specific specimens and materials. Removable screw-on/screw-off handles are provided for easy mounting and dismounting. In addition, special provision is made for other gripping assemblies to be threaded directly onto the grip axis to avoid grip removal.

Standard features

- Side mounting for easy specimen insertion
- Rated for static and fatigue operation
- Improved repeatability of test results attributed to uniform gripping at adjustable pre-set wedge pressure
- Choice of wedges to suit different specimen thickness
- Adjustable pressure
- Parallel action wedge grips



Specifications

Model no	Capacity kN	Weight kg	Wedge width mm	Model no for wedges	Wedge shape	Specimen dimensions*, mm		
AC-05-11T1	25	12	25	11T1-01, 11T1-02	Flat	0 - 5	5 - 10	
				11T1-11, 11T1-12	Vee	0 - 5	5 - 10	
AC-05-11T2	50	20	50	11T2-01, 11T2-02	Flat	0 - 9	9 - 16	
				11T2-11, 11T2-12	Vee	0 - 9	9 - 16	
AC-05-11T3	100	55	75	11T3-01, 11T3-02	Flat	0 - 9	9 - 16	16 - 25
				11T3-11, 11T3-12	Vee	0 - 9	9 - 16	15 - 20
AC-05-11T4	250	100	75	11T4-01, 11T4-02	Flat	0 - 9	9 - 16	16 - 25
				11T4-11, 11T4-12	Vee	0 - 9	9 - 16	16 - 25
AC-05-11T5	500	250	125	11T5-01, 11T5-02	Flat	0 - 9	9 - 16	16 - 25
				11T5-11, 11T5-12	Vee	0 - 9	9 - 16	16 - 25
				11T5-13, 11T5-14	Vee	0 - 9	9 - 16	16 - 25

*Dimensions are subjected to minor variations based on specific ratings

Dimensions

Load capacity (kN)	25 - 50	100	500
Max operating pressure (bar)	210	210	210
Diameter (Ø) (mm)	160	220	340
Over all height (mm)	175	200	270
Stud size	M27x2,RH	M27x2,RH	M50x2,RH

Wedges

Load capacity (kN)	Flat wedges		V - wedges diameter (mm)
	Thickness (mm)	Width (mm)	
25 - 50	0 - 10	35	Ø3 - Ø9
100	0 - 19	75	Ø2.5 - Ø16
500	0 - 44	110	Ø5 - Ø45

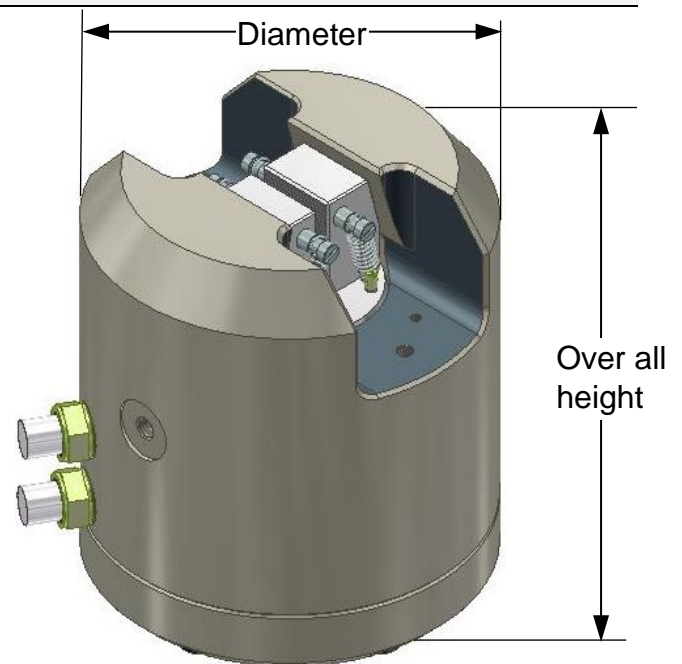

Note: Products and accessories can also be customized as per requirement.