

Electrochemical Test Cell ECC-Ref



User Manual

Release: 2.3

2014-01-22

© 2007 - 2014
EL-CELL GmbH

The information in this manual has been carefully checked and believed to be accurate; however, no responsibility is assumed for inaccuracies.

EL-CELL GmbH maintains the right to make changes without further notice to products described in this manual to improve reliability, function, or design. EL-CELL GmbH does not assume any liability arising from the use or application of this product.

Content

- 1 Product Description 3
- 2 Features 4
- 3 Safety Precautions 5
- 4 Unpacking..... 5
- 5 ECC-REF Assembly 6
- 6 Disassembly and Cleaning 14
- 7 Accessories and Spare Parts 15
- 8 Technical Support 16
- 9 Warranty 17



1 Product Description

The ECC-Ref Electrochemical Cell is a standard test cell for the characterization of lithium ion battery systems as well as other aprotic chemistries. With the ECC cell design we have adapted the advantages of the industry's standard coin cell while avoiding its serious shortcomings for everyday lab usage. The ECC cell design is the result of many years of experience and iterative improvement in lithium ion battery and supercapacitor electrode testing. It is perfectly suited for voltammetry and impedance as well as cycle life testing.

As a member of the modular ECC test cell series, the ECC-Ref test cell can easily be refitted for 2-electrode operation. This manual covers solely the ECC-Ref test cell.

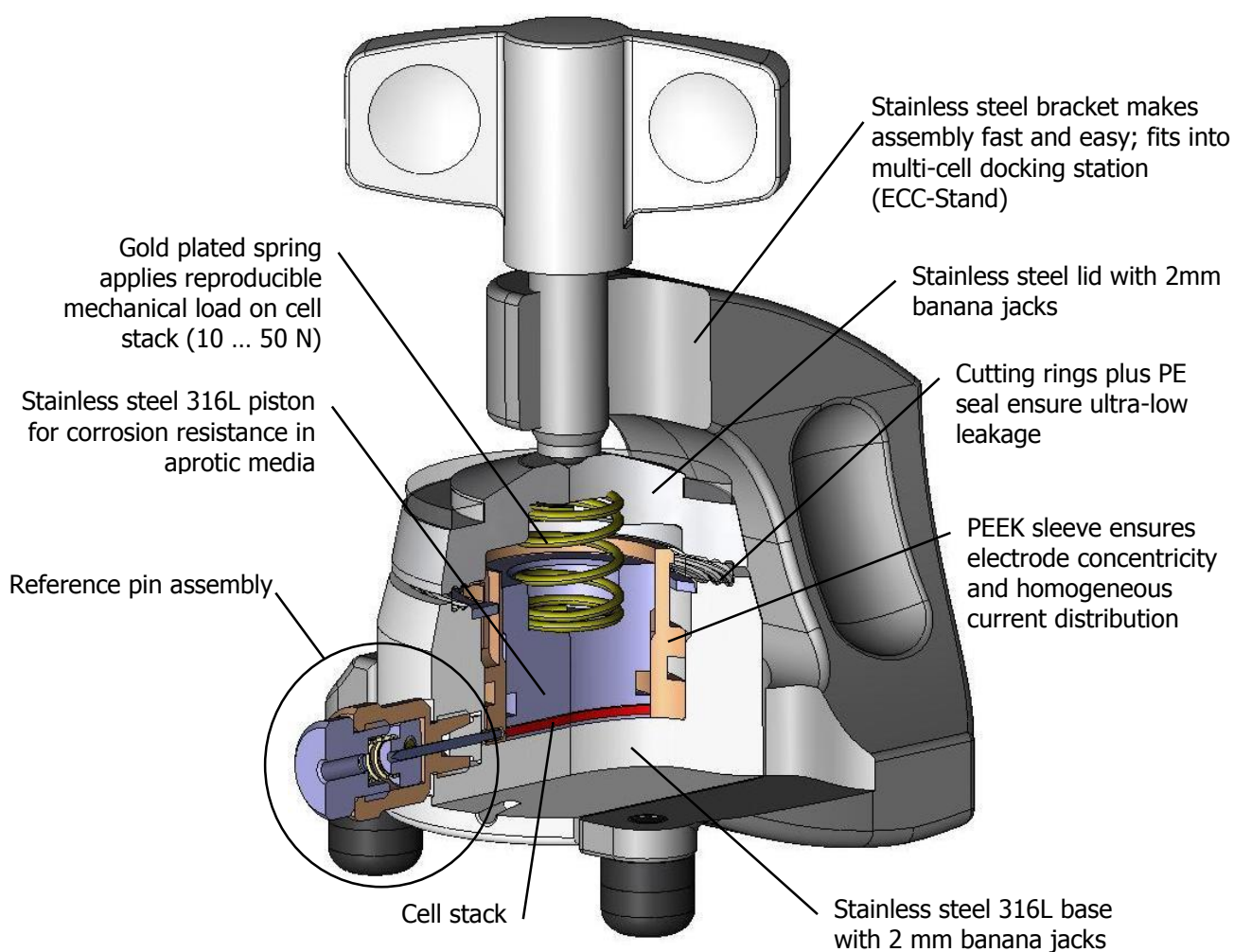

2 Features

- Precise 18 mm diameter sandwich geometry with <0.1 mm electrode concentricity
- Reliable ultra-low leakage sealing with PE seals
- Temperature operation range -40 to +80 °C
- Easy and reliable electrolyte filling upon assembly
- Fast assembly and dismantling, and easy cleaning of cell components
- Electrodes are easily accessible for post-mortem analysis
- Reusable cell components except for PE sealing
- Small and defined electrolyte volume down to 0.05 cm³
- Adjustable, reproducible and homogeneous mechanical pressure on electrodes

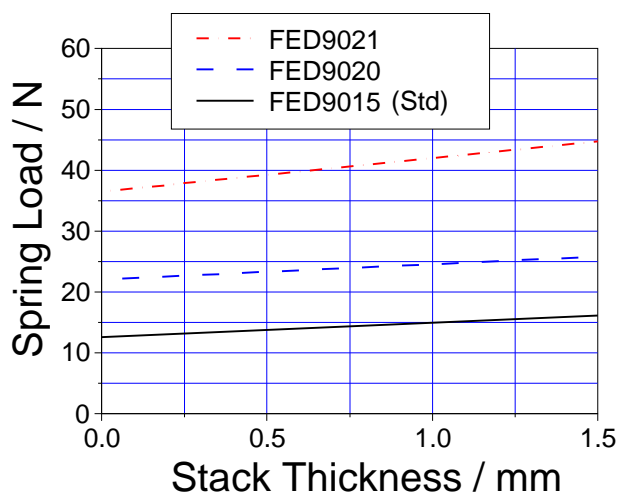

Spring load on stack vs. stack thickness for different springs. Standard is FED9015.

- Materials in media contact are stainless steel 316L and PEEK (other materials on request)
- Modular cell construction with many interchangeable components.
- Dedicated tools available to ease cell assembly and operation (<http://el-cell.com/products/accessories-tools>)
- “Plug and play” multi-cell fixture available for operation inside temperature chamber or wall mounting, and for connection to a multi-channel potentiostat or battery tester (<http://el-cell.com/products/accessories-tools/ecc-stand>)
- Size (including bracket): 90 mm x 54 mm x 70 mm (height x width x depth)
- Weight: 640 g

3 Safety Precautions

Use proper safety precautions when using hazardous electrode materials and electrolytes. Wear protective glasses and gloves to protect you against electrolyte that may accidentally spill out during filling and disassembly. Upon cell disassembly, dispose all materials properly. Metallic lithium and some insertion compounds may decompose heavily in contact with water and other solvents, and can cause fire.

4 Unpacking

Check the contents of the packages against the list given below to verify that you have received all of the components. Contact the factory if anything is missing or damaged. **NOTE:** Damaged shipments must remain with the original packaging for freight company inspection.

List of Components

1. Test cell with bracket
2. Reference electrode assembly
3. PE seals (10 pieces)
4. Glass Fibre Separator (10 pieces)

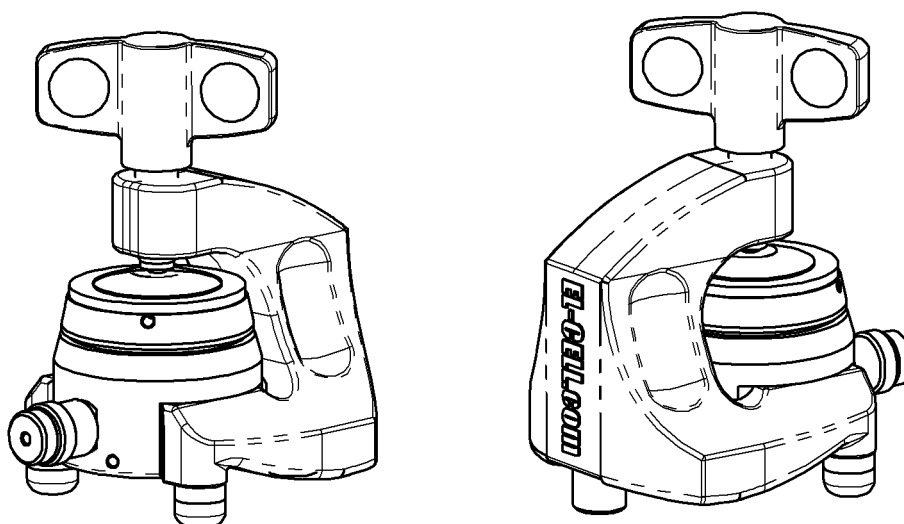

5 ECC-REF Assembly

In order to operate the test cell with a reference, the small feed-through hole of the REF sleeve is to be loaded with a piece of the reference material, e.g. metallic lithium. Alternatively, the feed-through hole is first loaded with a piece of fibre cloth serving as an electrolyte “wick”, and only then with the reference electrode material. After cell assembly the reference material is contacted from outside through the side opening by means of the spring loaded contact pin. Also, the contact pin itself may serve as the reference electrode (e.g. when using a silver pin). The vertical position of the reference is determined by the thickness of the components. Make sure that the electrodes and separator used have the appropriate thickness to avoid a short circuit between the reference and one of the two sandwich electrodes.

NOTE: By default, the REF sleeve comes with a 0.3 mm diameter bore. Depending on the reference or “wick” material used, it may be required to enlarge this bore. This can easily be done free-handed with the aid of a drill-bit. The REF bore diameter must not exceed 0.8 mm.

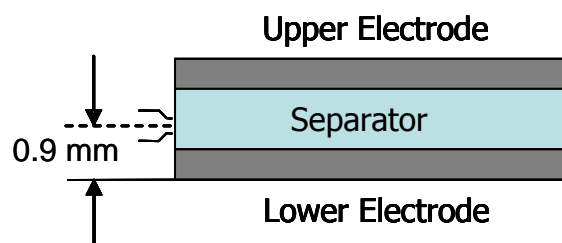

Assembly Steps for using a lithium REF and a non-lithium CE
(For using a lithium CE, see page 12):

- i) Pick up a small piece of lithium by a metal wire, and press the lithium into the feed-through hole of the REF sleeve until the lithium just arrives at the inner face of the sleeve, not less, not more. A dedicated tool, the ECC-RefLoad, is optionally available to ease this assembly step (<http://el-cell.com/products/accessories-tools/ecc-load>)
- ii) Insert the REF sleeve into the cell base.
- iii) Mount the locking ring to align the side opening of the cell base with the feed-through hole of the REF sleeve.
- iv) Attach the spring-loaded contact pin (REF electrode assembly) to the cell base.
- v) Place the counter electrode into the sleeve.
- vi) Put the glass fiber separator on top.
- vii) Dispense a defined amount of electrolyte onto the separator, and place the working electrode, with its active layer downside, on top inside the sleeve.
- viii) Insert the stainless steel 316L piston, the PE seal and the spring.

- ix) Attach the cell lid, insert the cell into the bracket, and tighten the wing nut.

Note: The adequate amount of electrolyte depends on the porosity and thickness of the components used. For the standard 1.5 mm thick glass fiber separator and standard Li-ion electrodes with <0.1mm thickness, an electrolyte amount of 0.5 ml is a good starting point.

The following pictures illustrate the assembly of the ECC-REF test cell.

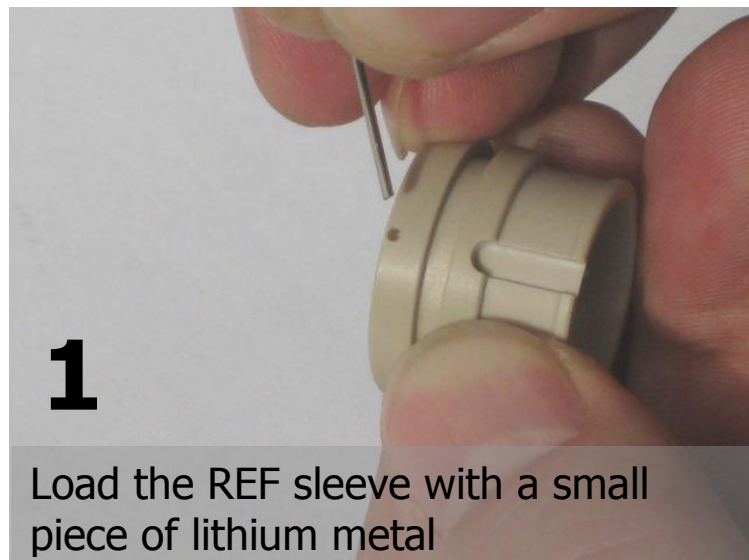

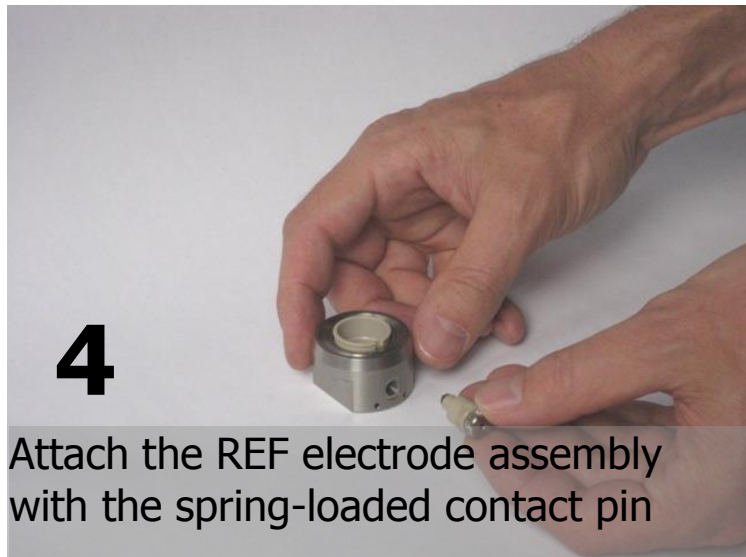

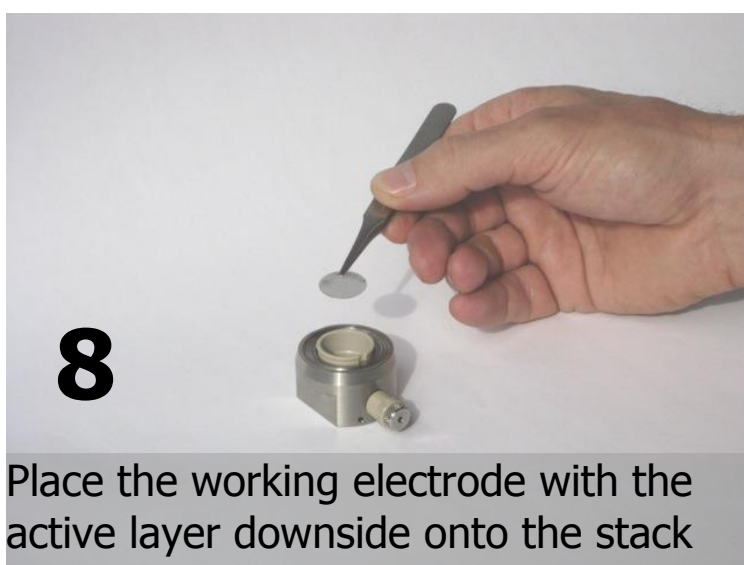
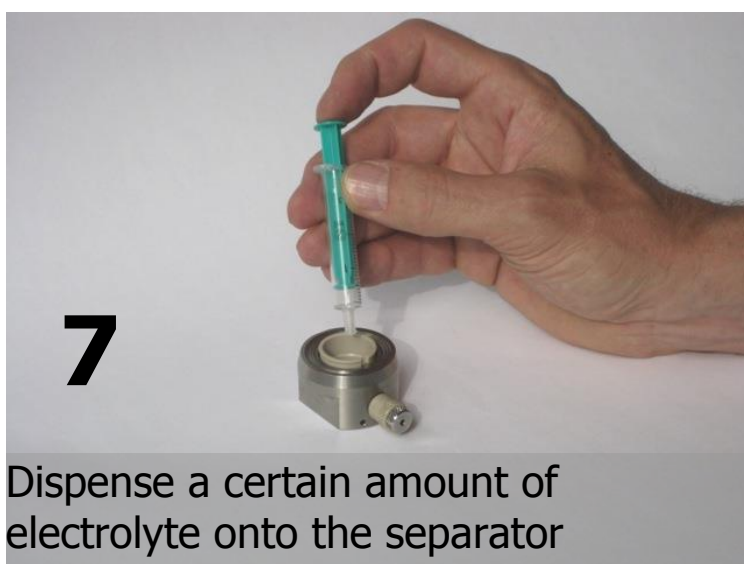





12

Put the lid on top



13

Press the lid down while pushing the cell into the bracket

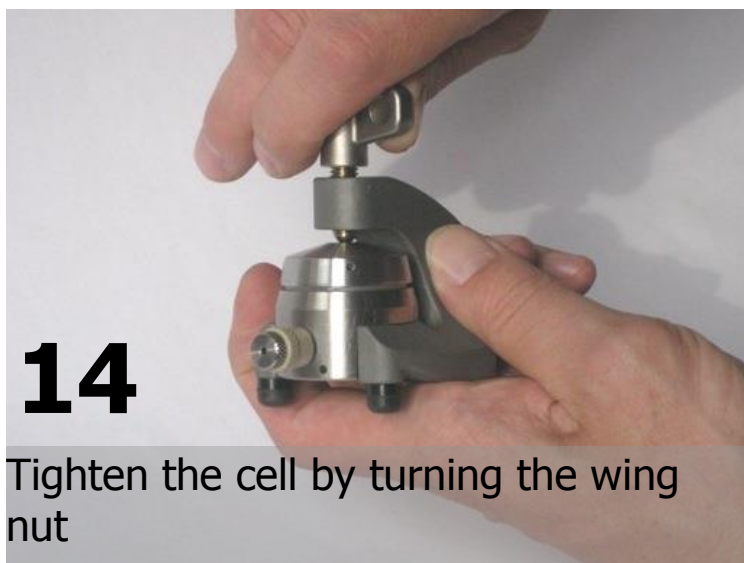

14

Tighten the cell by turning the wing nut

When using lithium metal as the counter electrode, we recommend following the modified procedure given below.

- i) Pick up a small piece of lithium by a metal wire, and press the lithium into the feed-through hole of the REF sleeve until the lithium just arrives at the inner face of the sleeve. A dedicated tool, the ECC-RefLoad, is optionally available to ease this assembly step (<http://el-cell.com/products/accessories-tools/ecc-load>)
- ii) Insert the piston into the sleeve and hold the piston/sleeve assembly with the contact face of the piston pointing upwards.
- iii) Put the separator onto the piston inside the sleeve.
- iv) Put the lithium CE disc onto the separator. A dedicated tool, the ECC-LiPunch, is optionally available to punch the 18 mm lithium electrode. (<http://el-cell.com/products/accessories-tools/ecc-lipunch>)
- v) Push the cell base over the assembly, hold the components tightly together, and turn the assembly back into the upright position.
- vi) Pull out the WE piston while retaining the sleeve at the bottom of the cell base. Both the lithium disc and the separator are now in place in the sleeve at the bottom of the cell base.
- vii) Mount the locking ring to align the side opening of the cell base with the feed-through hole of the REF sleeve.
- viii) Attach the reference pin assembly to the side opening of the cell base.
- ix) Dispense a defined amount of electrolyte onto the separator, and place the working electrode, with its active layer downside, on top inside the sleeve.
- x) Insert the WE piston into the sleeve.
- xi) Insert the PE seal and the spring.
- xii) Attach the cell lid, push the cell into the bracket, and tighten the wing nut.

Note: Check the thickness of the components used against the sketch on page 6. To avoid a short circuit of the reference with one of the two sandwich electrodes it might be necessary to use a thicker separator.

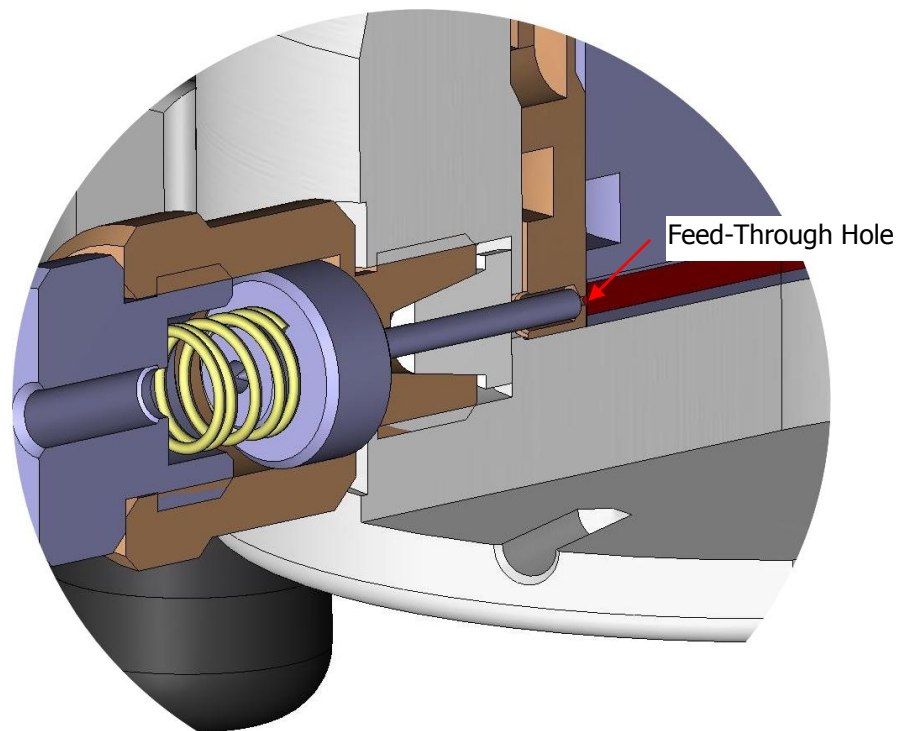
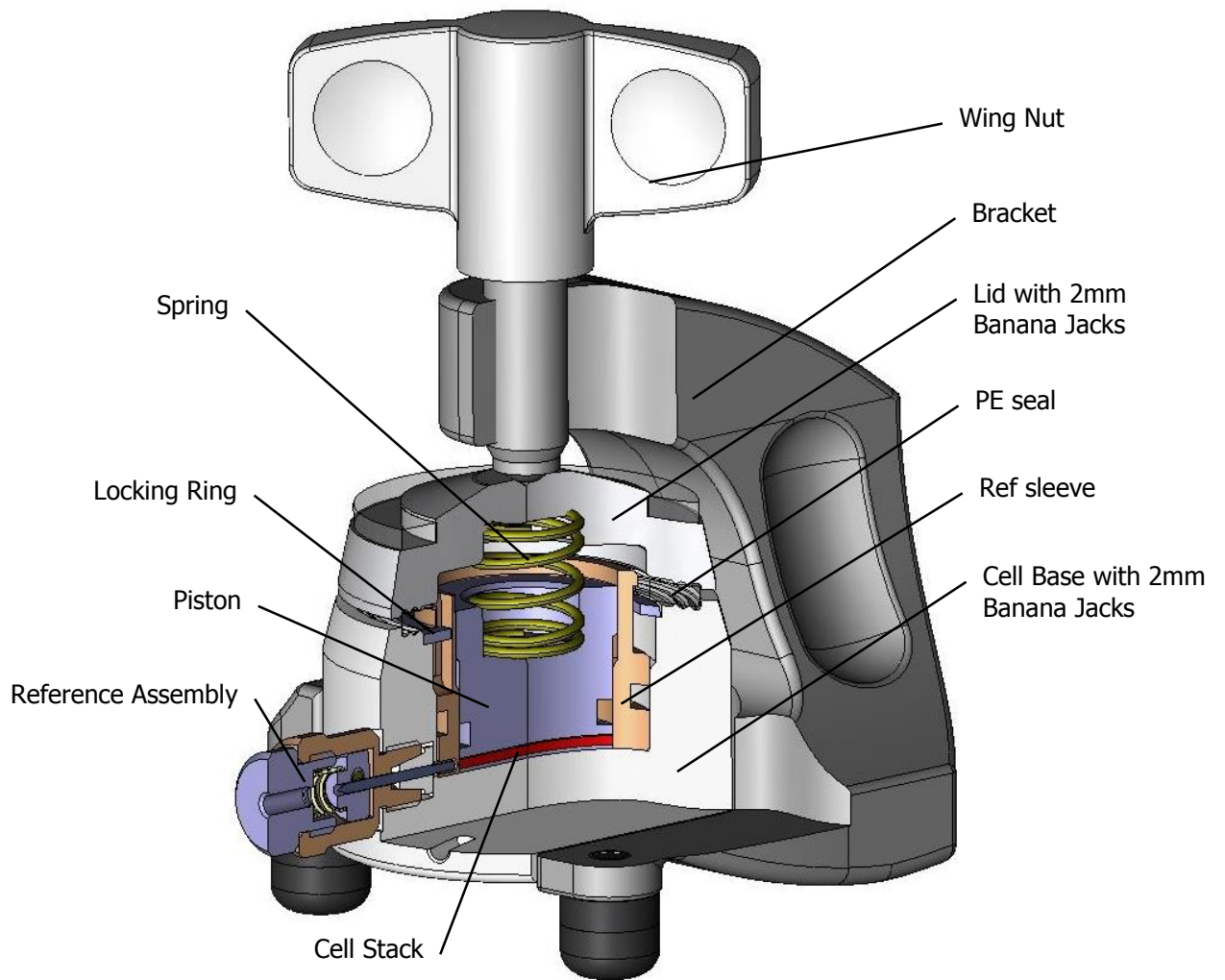

Detail view of the reference pin assembly

6 Disassembly and Cleaning

Right after use the cell is to be disassembled in the reverse order of assembly. Note that the reference pin **MUST** be detached before the REF sleeve can be removed.

All chemicals used have to be disposed properly. All wetted parts are to be cleaned with water and/or other appropriate solvents. Ultrasonic cleaning is recommended. Persistent dirt on the cell base and plunger may be removed by treating these components with aqueous nitric acid (20%, 2 hours at room temperature). All parts are to be dried immediately after cleaning at 80°C.

NOTE: Leaving cell parts in contact with ambient atmosphere while still being wetted with electrolyte may result in severe corrosion.

7 Accessories and Spare Parts

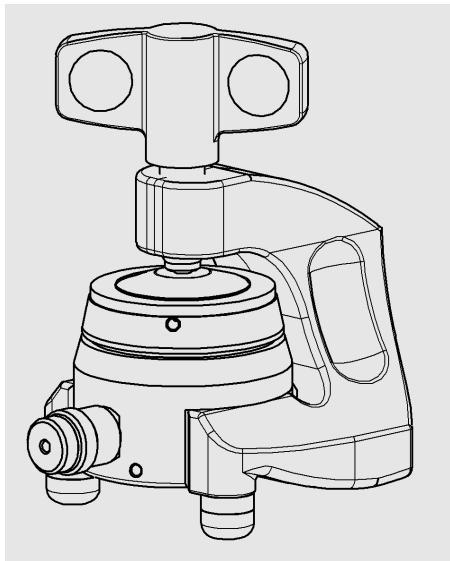

ECC-REF Test Cell

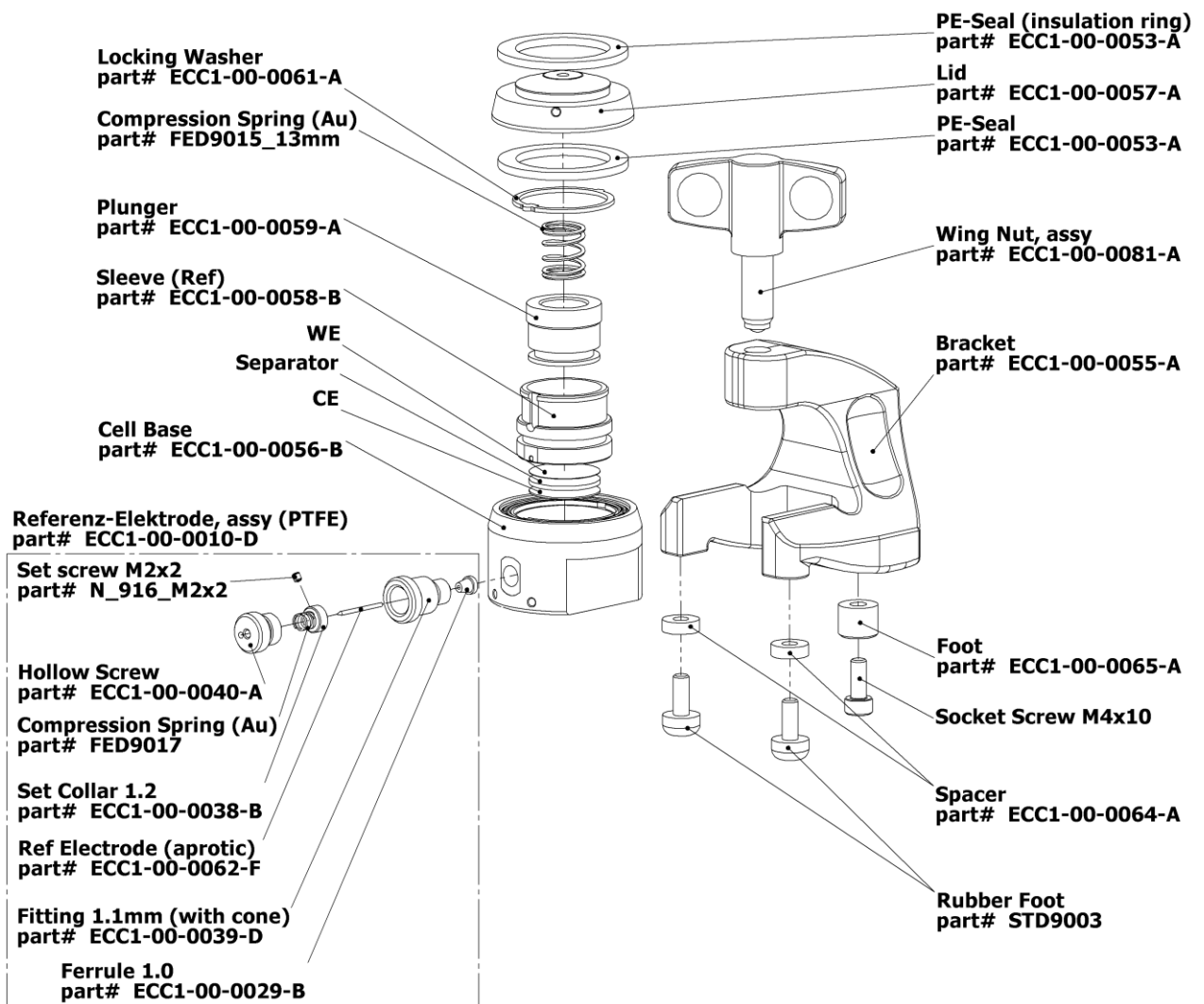

8 Technical Support

Technical support for this product is exclusively handled by EL-CELL GmbH. The following procedure must be followed when the ECC test cell or any part of it is returned to EL-CELL GmbH for repair:

1. Send an e-mail to info@el-cell.com to obtain a return authorization number and a decontamination report form.
2. Sign the decontamination report asserting that the instrument has been decontaminated and is safe for technicians to work on it.
3. Describe in detail what is wrong.
4. Include a contact name, address, telephone number, and email address.
5. Return the equipment to

9 Warranty

For a period of one year from the date of shipment, EL-CELL GmbH (hereinafter Seller) warrants the goods to be free from defect in material and workmanship to the original purchaser. During the warranty period, Seller agrees to repair or replace defective and/or nonconforming goods or parts without charge for material or labour, or, at the Seller's option, demand return of the goods and tender repayment of the price. Buyer's exclusive remedy is repair or replacement of defective and nonconforming goods, or, at Seller's option, the repayment of the price.

Seller excludes and disclaims any liability for lost profits, personal injury, interruption of service, or for consequential incidental or special damages arising out of, resulting from, or relating in any manner to these goods.

This Limited Warranty does not cover defects, damage, or nonconformity resulting from abuse, misuse, neglect, lack of reasonable care, modification, or the attachment of improper devices to the goods. This Limited Warranty does not cover expendable items. This warranty is void when repairs are performed by a non-authorized person or service centre. At Seller's option, repairs or replacements will be made on site or at the factory. If repairs or replacements are to be made at the factory, Buyer shall return the goods prepaid and bear all the risks of loss until delivered to the factory. If Seller returns the goods, they will be delivered prepaid and Seller will bear all risks of loss until delivery to Buyer. Buyer and Seller agree that this Limited Warranty shall be governed by and construed in accordance with the laws of Germany.

The warranties contained in this agreement are in lieu of all other warranties expressed or implied, including the warranties of merchantability and fitness for a particular purpose.

This Limited Warranty supersedes all prior proposals or representations oral or written and constitutes the entire understanding regarding the warranties made by Seller to Buyer. This Limited Warranty may not be expanded or modified except in writing signed by the parties hereto.