

iSorb™ HP1/HP2

High Pressure Gas Sorption Analyzer



iSorb HP1 / HP2

ISOTHERMS
PCT CURVES
HEATS OF ADSORPTION



Catalysts

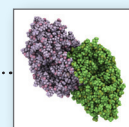

Ceramics



Energy



Carbon

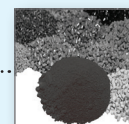

Pharma

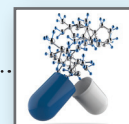

High Pressure Gas Sorption Analyzer

High pressure gas sorption has become an important characterization measurement for the study of sorbent materials primarily in the fields of carbon dioxide and methane sequestration, and of hydrogen storage, whether by physisorption mechanisms or hydride formation. It is also a commonly employed method in the study of microporous materials for gas separation. Volumetric measurements offer a robust, fully automated means of recording full adsorption and desorption isotherms over a wide range of pressures and temperatures. These instruments are sometimes referred to as Sieverts apparatus.

OVERVIEW

The iSorb series is a family of four such analyzers; one and two-sample models each available with an upper pressure limit of 100bar or 200bar. Each analyzer is equipped with a built in vacuum pump system, either a rotary oil-pump or a turbo pump-based system according to the end user's preference, and sample degassing capability.

The single-station model, the iSorb-HP, uses two pressure transducers in the dosing manifold and two more in the sample station for improved measurement accuracy over the entire pressure range from as low as 0.0005 bar. The two-station model, the iSorb-HP2, employs no less than six transducers...two in each of the sample stations and a further two in the dosing manifold. This arrangement not only ensures the wide pressure range capability but also allows simultaneous measurement capability on two samples.

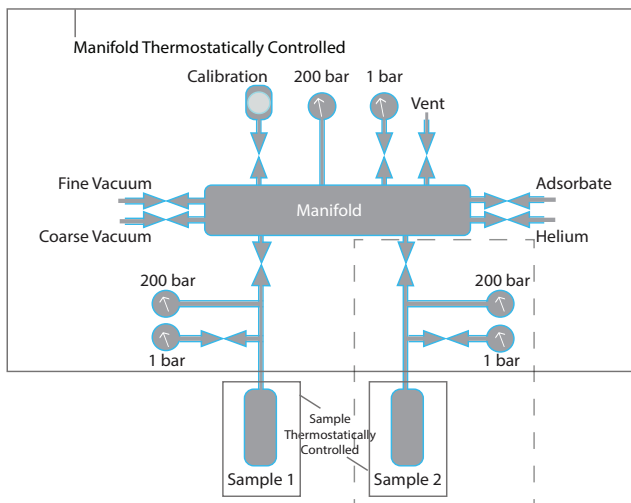

SAMPLE HANDLING

The stainless steel construction of both internal gas lines and sample cell assures safe operation, and the PC software constantly shows the pressures within the system together with any appropriate warnings. Safe manipulation of the sample cell, for example after the analysis, is guided by on-screen prompts. Samples can be prepared by degassing in-situ, thereby minimizing transfer of sample cells.

This degassing is done automatically by the instrument following a protocol programmed in the software. Adjustable degassing parameters include ramp rate, hold temperature, time under vacuum, final temperature and backfill state (vacuum or backfilled).

REAL HIGH PRESSURE CAPABILITY

For an extended supply of high pressure adsorptive (analysis gas) at up to 200bar, a heated booster option is available. Cylinder gas pressure is multiplied by the booster to provide adsorptive at pressures above those possible from a cylinder alone and can continue to provide high pressure gas even when the cylinder pressure drops as gas is being used. The heating of the booster and connection lines allows gasses that may condense at high pressure at room temperature for example; CO₂ to be supplied and used well above standard maximum cylinder pressure (57 bar at 21°C).

[See Accessories.](#)

TEMPERATURE RANGE

Sample temperature can be controlled in a variety of ways to suit the analysts' needs. The recirculator option provides a working range of -20°C to 100°C. Above 100°C, the heating mantle provides temperatures of up to 400°C. A liquid nitrogen system is available complete with sample dewar, level control and reservoir dewar. A CryoCooler system can also be connected for sub-ambient cooling down to -198°C and does not require liquefied cryogenic gases. The measurement manifold is thermostatically controlled from 35°C to 50°C and controlled to within 0.2°C; this allows the measurement of complete CO₂ isotherms up to the maximum instrument pressure (since the critical temperature of CO₂, (i.e. above which it will not liquefy, is 31°C).

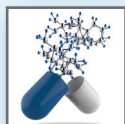
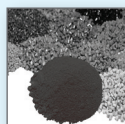
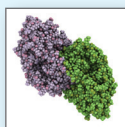

High Pressure Gas Sorption Analyzer

BENEFITS

High-Pressure Analysis:

Analysis pressures up to 200bar.

Efficient Use of Gas Source:

Optional booster compresses adsorptive gas for analysis, allowing pressures up to 200bar from tank pressures as low as 55bar.

Accurate Pressure Measurement:

High-precision pressure transducers measure pressure to within 0.05% (optional 0.01%) of full scale. High-pressure and low-pressure transducers allow pressure measurement in the optimum range of the transducers.

High Sensitivity:

Separate pressure transducers on the sample cell allow the cell to be isolated from the dosing volume for equilibration, thus reducing the void volume and increasing sensitivity.

Wide Range of Analysis Temperatures:

Choice of temperature control technologies offer a wide range of analysis temperatures, from below 75K up to 673K.

Efficient Outgassing:

Optional turbomolecular pump allows outgassing pressures as low as 10^9 m bar for removing adsorbed gas from microporous samples, even those with tortuous pore networks.

Flexibility:

A wide range of sample sizes and shapes can be accommodated by choosing from three different cell sizes.

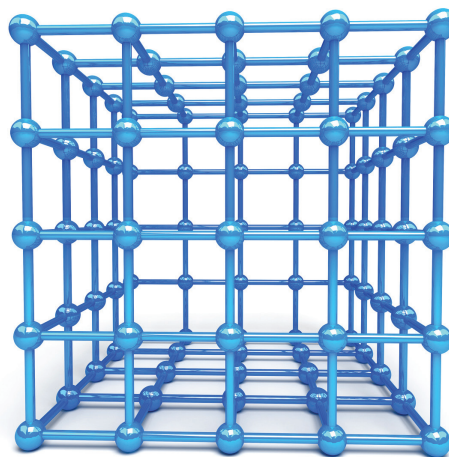

Precise Adsorptive Dosing:

Multi-point calibration of the dosing manifold and precise control of the manifold temperature allow accurate dosing of the adsorptive, even at high pressure.

Maximum Safety:

Numerous interlocks and safety features are built into the software and the instrument to ensure the safety of the operator, even when working at 200bar.

Leak Tight Manifold and Sample Cells:

Use of metal seals throughout, along with low-leak pneumatic valves ensure low leak rates and therefore accurate measurements of surface excess.

Flexible Software Interface:

Powerful Windows® based software provides a flexible interface for setting up experiments, controlling instrument functions, and displaying data. A full complement of classical and modern models for data reduction and display is included.

Easy Setup:

The system is supplied complete and ready for operation. Vacuum pump(s), temperature control, tubing, sample cells, etc. are all included.

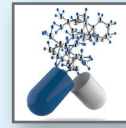
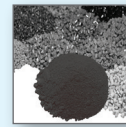
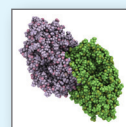

High Pressure Gas Sorption Analyzer

FEATURES

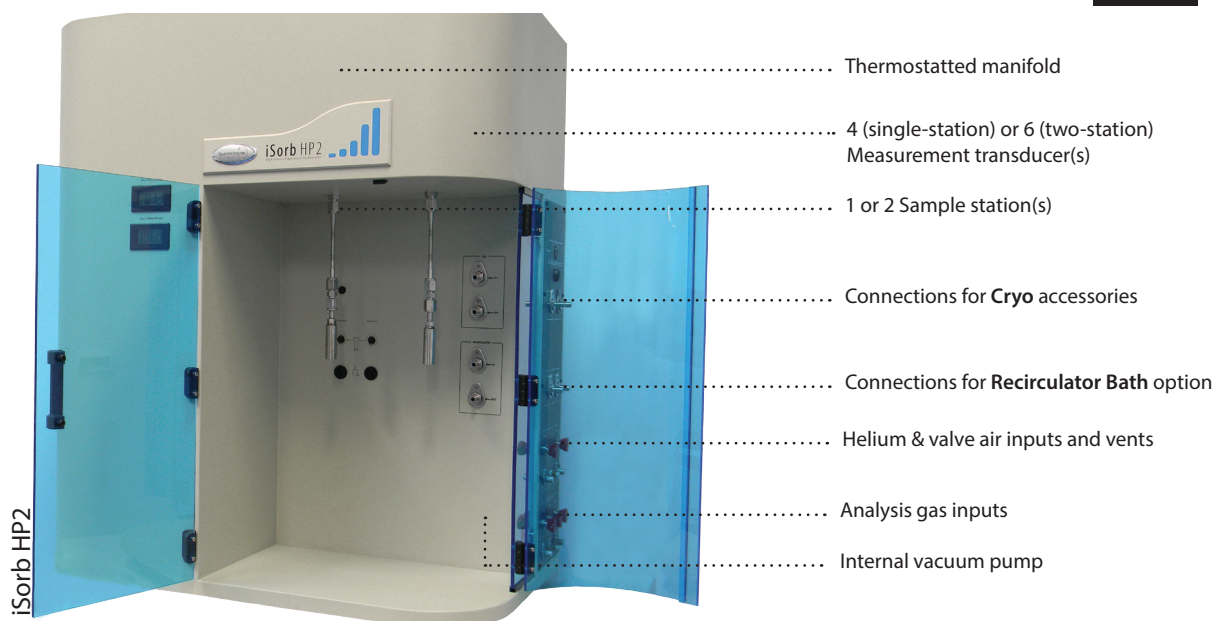

iSorb HP1 / HP2

SPECIFICATIONS

PERFORMANCE / PHYSICAL	isorb HP1	isorb HP2
Analysis stations	1	2
Gas inputs	2 (optional 4)	2 (optional 4)
Max pressure data	200 bar ^a	200 bar ^a
Min pressure data	0.0005 bar	0.0005 bar
LP transducers	2 (1 bar)	3 (1 bar)
HP transducers	2	3
Total transducer count	4	6
Transducer accuracy	<±0.05% f.s. ^b	<±0.05% f.s. ^b
Vacuum pump	internal	internal
Turbo pump option	yes	yes
Degas type	automatic	automatic
Degas ports	in-situ	in-situ
Max degas temp (°C)	400 ^c	400 ^c
Thermostatted bath (option)	yes	yes
Cryo option	yes	yes
Booster option	yes	yes
Thermostatted manifold	yes	yes
Gas inputs/vents location	Side, for easy access	Side, for easy access
Height	100 cm (39.25 in)	100 cm (39.25 in)
Width	85 cm (33.5 in)	85 cm (33.5 in)
Depth	50.5 cm (19.5 in)	50.5 cm (19.5 in)
Weight	150 kg (330 lbs)	150 kg (330 lbs)

^a or 100 bar for lower pressure model.

^b Optional <±0.01% f.s.

^c Using heating mantle(s) provided. Higher with external furnace.

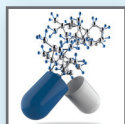
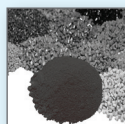
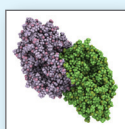

High Pressure Gas Sorption Analyzer

APPLICATIONS

Gas Storage

The use of activated carbons for carbon dioxide capture and methane storage is an active area of current investigations. These activated carbons, whether derived from biomass or from other sources are characterized by their micropore volume and micropore size distribution at low temperatures and pressures, however, to best correlate these micropore characteristics to storage capacity, high pressure adsorption studies at near ambient temperatures are needed to more closely simulate the conditions under which the storage will occur. The iSorb HP is capable of determining the adsorbed amount and storage capacity of gasses up to 200bar at room temperature, giving the development teams accurate indication of the effectiveness of candidate materials.

Separation and Purification of Gasses

Separation of gas mixtures for applications such as carbon dioxide capture in flue-gas streams or purification of methane gas is frequently accomplished by selective adsorption of one gas over another on a tailored adsorbent surface. In developing and optimizing these adsorbents it is important to quantitatively characterize the relative adsorptivity of the gases in the mixture. This can easily be accomplished with the iSorb HP through precise determination of the heats of adsorption of the component gasses at high pressures over the range of temperatures of interest.

Material Characterization

Novel compounds and various forms of activated carbons are being synthesized in labs all over the world. These materials must be characterized to determine their suitability for the target applications. Traditionally this involves the measurement of the pore size distribution, and BET surface area among other techniques. Pore size analysis for microporous materials is typically done with nitrogen or argon at cryogenic temperatures; however, these techniques are sometimes kinetically limited due to the tortuosity of the pore networks and the size of the pores. Carbon dioxide at 0°C is frequently used in determining the micropore size distribution of carbons, however, determining the mesoporosity of these materials with CO₂ requires pressures well above atmospheric pressure. The iSorb HP is well suited to measure CO₂ isotherms at 0°C up to the saturation pressure, allowing micropore and mesopore information to be determined.

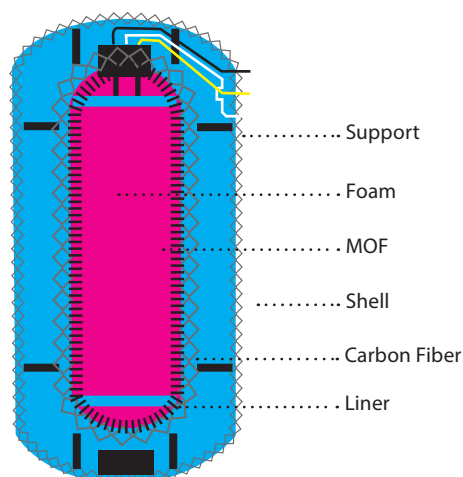

Kinetic and Thermodynamic Studies

The use of hydrides to increase the storage capacity of hydrogen is being investigated. Hydrides offer a significant increase in capacity over adsorbents exhibiting only physisorption of the hydrogen. The disadvantage of hydrides is that the rate at which they are formed and decomposed can lengthen the time to fill the reservoir or retrieve the gas for use. Measuring the rates of formation and decomposition can help understand which hydrides are viable and which are not. Using the large expansion volume of the Solid-Gas Process Kinetics (SGPK) option allows the determination of the rates of formation and decomposition at near-isobaric conditions.

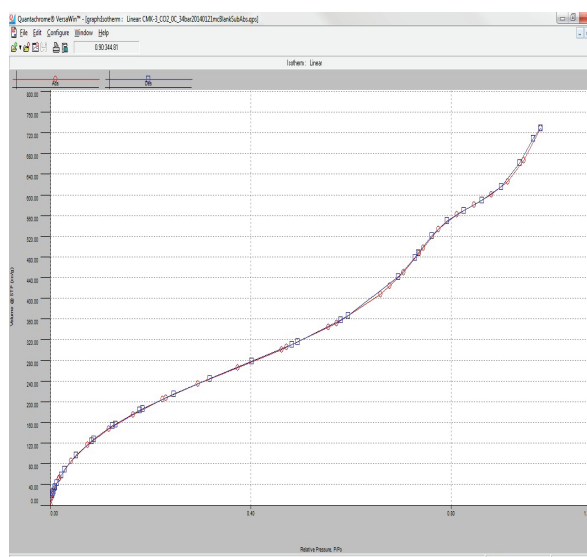

iSorb HP1 / HP2

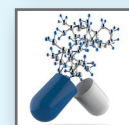
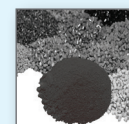
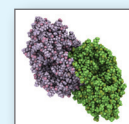

High Pressure Gas Sorption Analyzer

SOFTWARE

The associated software allows the user to define a measurement in terms of target pressure points or dose amount for both adsorption and desorption, complete with custom equilibrium criteria, sample temperature (according to the heating/cooling device selected) and choice of equation of state(EOS):

- Schmidt-Wenzel type, defined in terms of Helmholtz free Energy (NIST recommended)
- MBWR (Modified Benedict-Webb-Rubin type, Jacobsen 32-coefficients, NIST recommended)
- Lee-Kesler (generalized Benedict-Webb-Rubin)
- Peng-Robinson
- Soave-Redlich-Kwong
- Redlich-Kwong
- Van der Waals
- Ideal gas

* Not all EOS available for all gases

Safety interlocks and warnings throughout the program are designed to prevent the user from performing operations that could damage the instrument or cause personal injury. Precise control of the temperature of both the manifold and the sample are essential for accurate measurements close to the critical point of the adsorptive. This is illustrated by the adsorption isotherm of carbon dioxide on activated carbon at 45°C as shown in the **figure 2**:

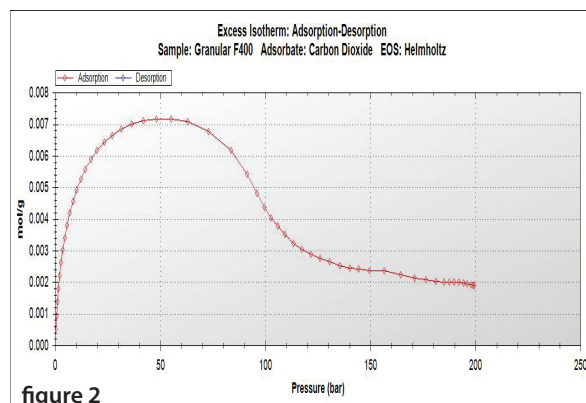

figure 2

An intuitive user interface displays the current status of the valves, current pressures of the manifold and sample cell(s), and status of all available accessories. See **figure 1**.

Pull-down menus give access to all instrument and measurement parameters, and post-processing functions. During analysis the operation of the instrument is completely automated, however, a manual mode allows all valves and accessories to be controlled by a simple click of the mouse.

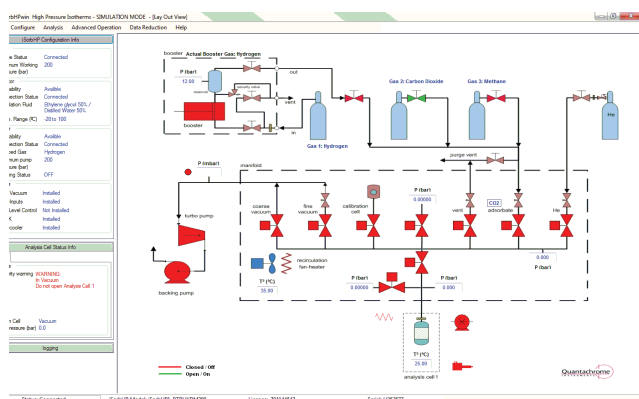

figure 1

A unique feature of the software is its ability to estimate the absolute adsorbed amount of adsorbate. All gas adsorption instruments measure the surface excess rather than the adsorbed amount. For low pressures (below one atmosphere) this is essentially the same as the adsorbed amount, however, at high pressures where the density of the bulk gas approaches the density of the adsorbed phase, the difference is significant. **figure 3** shows both the surface excess (diamonds) and adsorbed amount (stars) of methane on activated carbon. At low pressures the curves overlap, but at high pressures the difference is evident.

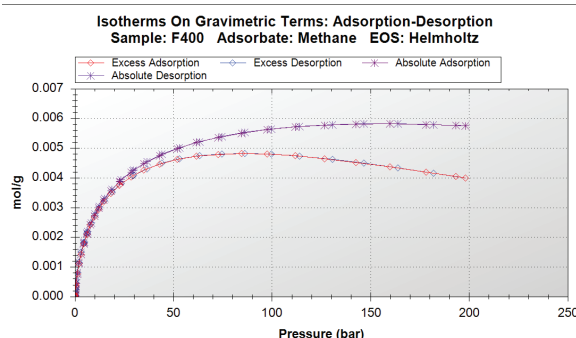
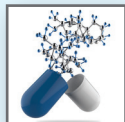
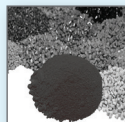
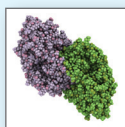

figure 3

iSorb HP1 / HP2



High Pressure Gas Sorption Analyzer

ACCESSORIES

Several accessories are available for the iSorb HP1 and iSorb HP2 analyzers to increase flexibility and allow the instrument to be tailored to the needs and applications of the individual laboratory.

LN₂ Control System

For operation at liquid nitrogen temperature (77.3K) a liquid nitrogen control system is available. This accessory consists of a sample dewar, a 60L self-pressurized supply dewar, LN₂ level sensor, and insulated supply lines. The software automatically maintains the LN₂ level in the sample dewar by adding small amounts of LN₂ from the supply dewar as needed.

Multi-Gas Ports

When frequently switching gasses used for analysis, it can become tedious to continuously connect and disconnect the different gas tanks from the instrument. The Multi-Gas Ports option provides a means of simply selecting the gas through the software. This is especially convenient when routine analysis involves collecting isotherms of multiple gasses, e.g. H₂ and CO₂.

Booster

When working at pressures up to 200 bar the pressure in the gas tank will quickly drop below the maximum working pressure. In order to extend the life of the gas tanks and provide sufficient pressure of analyses up to 200 bar, a Booster option is available. It is strongly recommended for 200 bar systems and can also be quite useful for 100 bar systems.



LN₂ Option

CryoCooler

The CryoCooler is a self-contained refrigeration system, which can maintain the sample cell temperature to within 0.1K at temperatures from 75K up to 320K. This wide range of temperatures allows for surface area analysis at cryogenic temperatures as well as super critical analyses at higher temperatures. It is ideally suited for obtaining several isotherms at closely spaced temperatures when studying the heats of adsorption of a sample. The CryoCooler is completely cryogen-free, thus reducing cost of operation where liquefied gasses are not readily available.

Solid-Gas Process Kinetics

When studying processes, such as hydride formation/decomposition, large amounts of gas can be required/released. In order to study the kinetics of these processes the Solid-Gas Process Kinetics (SGPK) option provides a large reservoir attached to the manifold, which provides a volume in which to expand.

Recirculator

Precise control of the sample temperature is essential for accurate data, especially when working close to the critical point of the adsorptive gas. The Recirculator is the most common method of regulating the sample temperature. It is completely software controlled, ensuring unattended operation at temperatures from -20°C up to 100°C and maintains it to within 0.01°C.

Miscellaneous

A variety of gas regulators, sample cells, UPS, and other accessories are available. Ask your local Quantachrome representative about what is available.

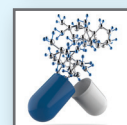
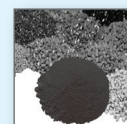
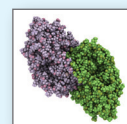



For over 45 years, Quantachrome's scientists and engineers have revolutionized measurement techniques and designed instrumentation to enable the accurate, precise, and reliable characterization of powdered and porous materials. We have an unwavering commitment to providing state of the art technology, and unparalleled superior customer service and support. Our commitment to customers is to support you before, during, and after the sale throughout the lifetime of our instruments. This is a big commitment because our products are so robust and reliable that we regularly find many still in use for decades.

Renowned innovator for today's porous materials community.

Quality Function Dependability

The quality of Quantachrome's after sales service support is the reason we are proud to maintain life time relationships with our customers.

Field Service



Our global service staff assure you that Quantachrome Instruments will continue to be the reliable engines of material characterization laboratories. We offer you the flexibility of choosing from service contracts tailored to provide you with the response time, service package, and spare parts discounts that best fit your needs.

Spare Parts



Quantachrome spare parts are certified to work with our instruments. We provide rapid response spare parts orders, and keep large inventories of replacement parts and hardware available.

Application Lab



Our fully equipped, state-of-the-art powder characterization laboratory, LabQMC (www.labqmc.quantachrome.com, qc.lab@quantachrome.com), provides the option of contracting for expert testing services. Laboratory services are also available to validate the applicability of our products prior to your purchase using your actual samples.

Lifetime Application Support



We view the field support of our instruments as an essential component of our business strategy. Our expert scientists are always available to answer questions on applications, or the use of our instruments. We do this as a standard service regardless of whether you have a service contract with us or not.

Partners in Science



Quantachrome has a scientific research department who are world renowned experts in material characterization. Our staff, led by Dr. Matthias Thommes, conduct collaborative research projects with leading material research labs around the world. They regularly publish articles in leading peer reviewed journals, and speak at technical symposiums around the world.

Corporate Headquarters-USA

Quantachrome Instruments
1900 Corporate Drive
Boynton Beach, FL 33426
Tel: + 1 800. 989 2476
+ 1 561. 731.4999
Fax: + 1 561. 732.9888
email: qc.sales@quantachrome.com
www.quantachrome.com

China

Quantachrome Representative Office
www.quantachrome-china.com
email: order.china@quantachrome.com
Tel: 800.810.0515
+ 86.10 64400892

United Kingdom

Quantachrome UK Ltd.
www.quantachrome.co.uk
email: info@quantachrome.co.uk
Tel: + 44 (0) 1252 819 719

Germany

Quantachrome GmbH & Co. KG
www.quantachrome.de
email: info@quantachrome.de
Tel: + 49 (0) 8134 93240

Japan

Quantachrome Instruments Japan G.K.
www.quantachrome.co.jp
email: sales.japan@quantachrome.com
Tel: 044.829.1525

India

Quantachrome India
www.quantachrome.com
email: pankajkadam@quantachromeindia.in
Tel: + 91 22 2589 5858

Your local Representative:

Trademarks and registered trade mark are the property of their respective owners.