

CONSUMABLES

STANDARD RESINOID CUT-OFF WHEELS

REF.	DESIGNATION	DIAMETER	HARDNESS	MATERIALS
01015	Type A abrasive Al ₂ O ₃ (ferrous materials)	Ø 250 x 1.6 x 32mm*	100 - 350 Hv	Low carbon, mild and extra mild and treated steels with medium cross-sections
01021		Ø 300 x 2 x 32mm*		
01002	Type AO abrasive Al ₂ O ₃ (ferrous materials)	Ø 200 x 1.6 x 25.4mm	300 - 500 Hv	Low carbon, mild and extra mild and treated steels with medium cross-sections
01014		Ø 250 x 1.6 x 32mm*		
01020		Ø 300 x 2 x 32mm*		
01012	Type AOF II "S" abrasive Al ₂ O ₃ (ferrous materials)	Ø 250 x 0.8 x 32mm	80 - 300 Hv	Rubber bonded cut-off wheel, thin section cutting, low cross-section sintered steels, hard metal layers
01001	Type AOF II abrasive Al ₂ O ₃ (ferrous materials)	Ø 200 x 0.8 x 25.4mm		
01013		Ø 250 x 0.8 x 32mm		
01019		Ø 300 x 1 x 32mm		
01018	Type F abrasive SiC (non ferrous materials)	Ø 250 x 1.6 x 32mm*	150 - 400 Hv	White, grey and spheroidal graphite cast iron, titanium and alloys
01024		Ø 300 x 2 x 32mm*		
01005	Type MNF abrasive SiC (non ferrous materials)	Ø 200 x 1.6 x 25.4mm	30 - 350 Hv	Aluminium, copper and alloys, non ferrous metals, titanium and alloys
01017		Ø 250 x 2 x 32mm*		
01023		Ø 300 x 2 x 32mm*		
01060	Type SiC abrasive SiC	Ø 180 x 0.5 x 25.4mm	450 - 700 Hv	Treated steels, with fragile coatings, difficult materials
01016	Type S abrasive Al ₂ O ₃ (ferrous materials)	Ø 250 x 1.6 x 32mm*		
01022		Ø 300 x 2 x 32mm*		
01071	Type T abrasive SiC (non ferrous materials)	Ø 250 x 1.6 x 32mm*		
01072		Ø 300 x 2 x 32mm*		

DIAMOND CUT-OFF WHEELS

REF.	DESIGNATION	DIAMETER	MATERIALS
02038	Type LM	Ø 200 x 0.9 x 32mm*	Ceramics, composites, tungsten carbide, alumina, sintered carbides
02042		Ø 250 x 1.2 x 32mm*	
02046		Ø 300 x 1.4 x 32mm*	
02040	Type LM+	Ø 200 x 0.9 x 32mm*	Ceramics (large sections), tungsten carbide, silicon carbide, plasma deposit, mounted samples, refractory materials, minerals, concretes
02044		Ø 250 x 1.2 x 32mm*	
02048		Ø 300 x 1.4 x 32mm*	
02041	Type LR	Ø 200 x 0.9 x 32mm*	Composites, plasma deposit, ceramics, electronic components
02045		Ø 250 x 1.2 x 32mm*	
02049		Ø 300 x 1.2 x 32mm*	

LM **Metallic bond.** Very polyvalent cut-off wheel, normal concentration, to cut hard materials such as:
 — ceramics, composites, tungsten carbide, alumina, sintered carbides.

LM+ **Metallic bond.** High concentration disc to cut hard materials such as:
 — ceramics (large sections), tungsten carbide, silicon carbide, plasma deposit, mounted samples, refractory materials, minerals, concretes...

LR **Resin bond.** High concentration disc, advised when you want the best cutting quality. To cut hard and fragile materials:
 — composites, plasma deposit, ceramics, electronic components...

BORON CARBIDE CUT-OFF WHEELS

REF.	DESIGNATION	DIAMETER	MATERIALS
02039	Type NB	Ø 200 x 0.9 x 32mm*	Cast irons, treated steels, hard and high speed steels
02043		Ø 250 x 1.2 x 32mm*	
02047		Ø 300 x 1.2 x 32mm*	

NB **Resin bond.** High concentration disc of boron nitride edge to cut:
 — Cast irons, treated steels, hard and high speed steels

* To be used with reduction ring (Ref. 01092)

PRESI IS ALSO...

CUTTING



Mecatome T330

MOUNTING



Mecapress 3

POLISHING



Le Cube

HARDNESS TESTING



Microtech MX 1

POLISHING



Mecatome 334



MECATOME ST 310

INNOVATION IN CUTTING



New manual cutting system.

High capacity machine: possibility of cutting large and long workpieces. Simple and adaptable, 4 preset speeds for getting best cutting results regardless the type of materials.

FUNCTIONALITIES

REF. 50200

Width	660mm + 120 mm for the swinging arm
Depth	880mm
Height closed lid	660mm
Height opened lid	970mm
Weight	120 kg
Conformity	EC

Manual abrasive cut-off machine with a swing action for increased cutting speed

MECATOME ST 310 with its PRESI exclusive swing arm action provides for increased length of longitudinal cut capacity and rapid sectioning without burning making it the highest performer in its class.

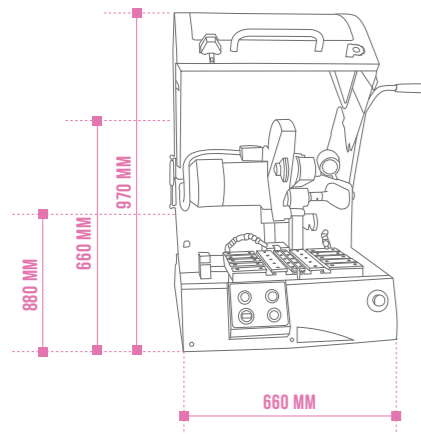
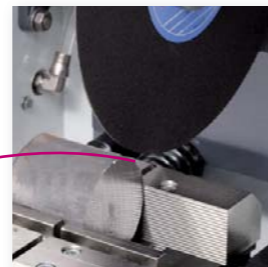
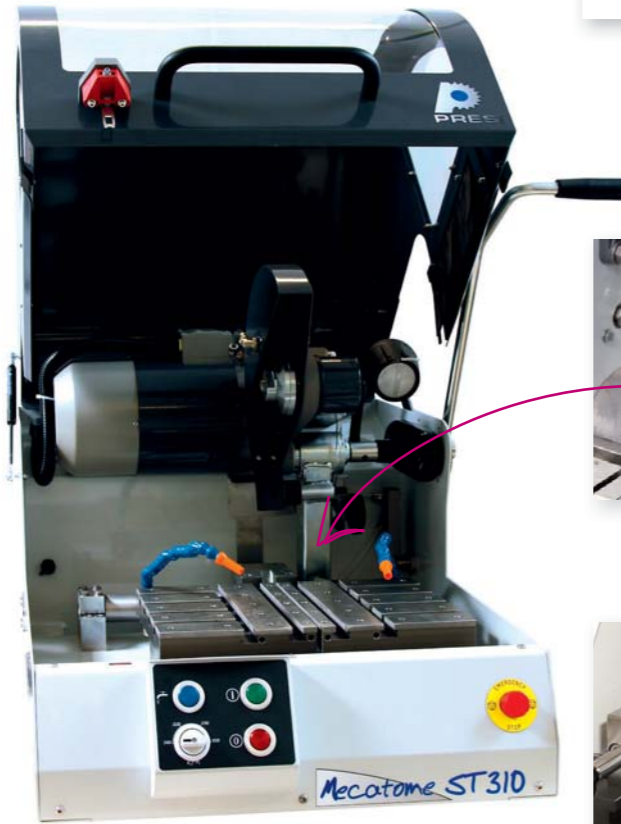

CUTTING ENVELOPE*

A choice of 250mm or 300mm diameter cut-off blades coupled with up to 4 pre-set rotational speeds provides the optimum cutting condition for a wide range of materials. The MECATOME ST 310 has been designed with the need to be able to easily accommodate samples that are longer than the chamber through the use of removable side ports. Sample set up is easy with the raised "T" slot bed, large, well lit cutting chamber and wide open access thanks to a fully retracting hood. Observation of the sample during the cutting operation is enhanced with the provision of extra-large windows in the hood.

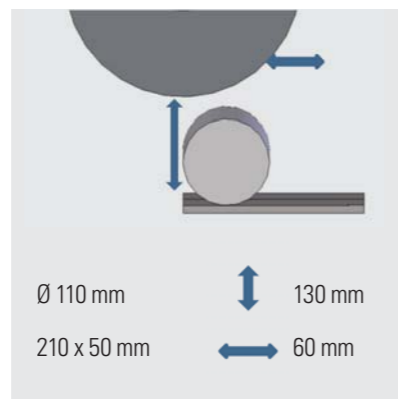

* This illustration of the cutting envelope of the MECATOME ST 310 is to show the maximum theoretical capacity only. The actual capacity in practice will depend on the sample geometry and its physical properties.

SWINGING MOVEMENT

MECATOME ST 310 equipped with a swinging movement allows a **60% time saving** compared with traditional cutting machine and means for the user, a significant reduction of effort

The contact point between sample and cut-off wheel is always different: so easier is the cut.

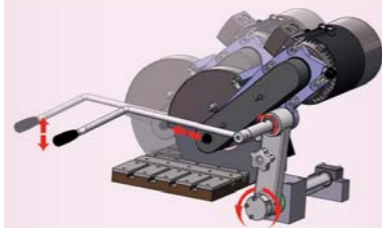

CHARACTERISTICS

HOOD	
Type	PETG enclosure with metal hinges and gas strut assisted lift
Safety	Interlock switch keeps hood locked during cutting
MOTORIZATION- POWER SUPPLY	
Power	3 700 W
Power supply	380 V / Three-phases / 50 Hz
Control of the motor	Frequency inverter
CUT-OFF WHEELS	
Type of cut-off wheels	Resin bonded and metal bonded
Cut-off wheel size range	Up to 300mm
Rotation speed	2.800, 3.200, 3.700 or 4.000 RPM
Arbor size	25.4mm
CONTROL	
Control Interface	Push buttons
CUTTING	
Cutting modes	Manual swing action
Table dimensions	390 x 290mm
Distance between cut-off wheel and table	130 mm (with a Ø 300mm wheel)
Type of table	Treated aluminum table with exchangeable stainless blocks
Holders	Any sample fixturing system compatible with a 12mm "T" slot bed
LUBRICATION-COOLING	
Pump & tank	External-60 L
Type of lubrication	External recirculating system
Method of directing pumped coolant	2 ports in the wheel guard 2 alignable nozzles in the cutting chamber
Type of filtration	100 µm washable filter cloth
ERGONOMICS	
Internal lighting	LED
Spray nozzle for cleaning	Integrated
CONFORMITY	
Conformity	EC

ACCESSORIES

Vices and Holders

51319
Right quick clamping vice

51321
Left quick clamping vice

50906*
Left and right quick clamping vices
Height 45mm

50905*
Left quick clamping vice
Height 45mm

50909*
Right quick clamping vice
Height 45mm

50902*
Double screw clamping vices Left and Right
Height 45mm

50901*
Left screw clamping vice
Height 45mm

50903*
Right screw clamping vice
Height 45mm

50613
Box of Kopal holders

50616
Kopal holding

Tables and positioning

51610
Manual X-axis table

Other accessories

51006
Base Cabinet
Width 770mm x depth 880mm
x height 855mm

51620
Set of 3 filters for coolant tank
ST310/T330/T300

* Stainless steel



REF. 50905



REF. 50909



REF. 50902



REF. 50901



REF. 50903



REF. 50613



REF. 50616



REF. 50610



REF. 51006



REF. 51620