

MF 48/-R

True Versatility

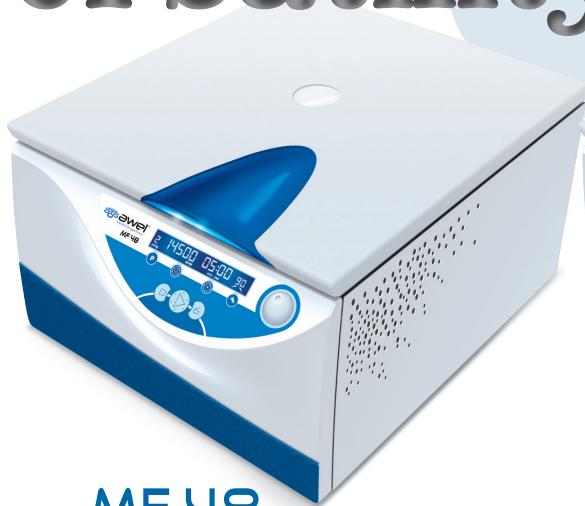

MF 48
Ventilated



MF 48-R
Refrigerated

QUICK FACTS



4 x 400 ml
76 tubes



14000 rpm



20800 xg

MULTIFUNCTION CENTRIFUGES

The MF 48 series, **4x400 ml**, offers a 28 x 15ml tubes & 2 Deep Well blocks capacity in optimized dimensions. Perfect control of the centrifugation cycle : programmable acceleration and braking rates and precise control even at low speed.

Refined ergonomics: convenient working height, AWELock rapid rotor exchange, AWELight illuminated handle to indicate end of run, motorized lid opening...

- Rotor exchange without tool
- Compact design
- Large choice of accessories
- Ease of use
- End of run indication

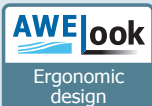

French design and manufacturing

The development program has resulted AWEL centrifuges including the filing of 4 patents in 2009.



AWEL, a new French brand of centrifuge, is positioned today as the **alternative** for your laboratories in research, clinical and transfusion applications. Their design, targeted towards **ergonomics**, is a reference in safety and convenience. The technical innovations optimize **productivity** in your laboratory work.

[Machine specifications]

Specifications	MF 48	MF 48-R
Max. speed Swing-out rotor Angle rotor	4500 rpm 12600 rpm	4500 rpm 14000 rpm
Max. RCF Swing-out rotor Angle rotor	3820 xg 17800 xg	3820 xg 20800 xg
Max. capacity Swing-out rotor Angle rotor	4 x 400 ml 6 x 100 ml	4 x 400 ml 6 x 100 ml
Control system	microprocessor	microprocessor
Speed range	500 to 12600 rpm	500 to 14000 rpm
Speed precision	20 rpm	20 rpm
Temperature Range	-	-20 to +60°C
Timer	0 - 99h50 and continuous	0 - 99h50 and continuous
Acceleration / Braking Rates	10 / 10	10 / 10
Programs	10	10
Lid Opening	motorized	motorized
Motor type	induction	induction
Certification	EC marked : IEC 1010-1 ; IEC 1010-2-020 Directives	
Dimensions (HxWxD)	280 x 420 x 520 mm	280 x 420 x 750 mm
Crating (HxWxD)	460 x 610 x 650 mm	460 x 610 x 890 mm
Weight (Net/Crated)	50 / 56 kg	70 / 79 kg
230 V - 50 Hz version	20022001	20023001
120 V - 60 Hz version	20022011	20023011

[Dimensions]

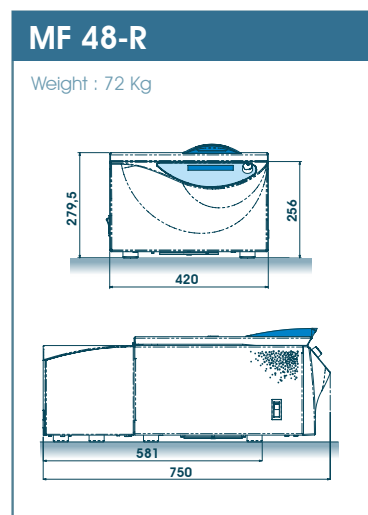
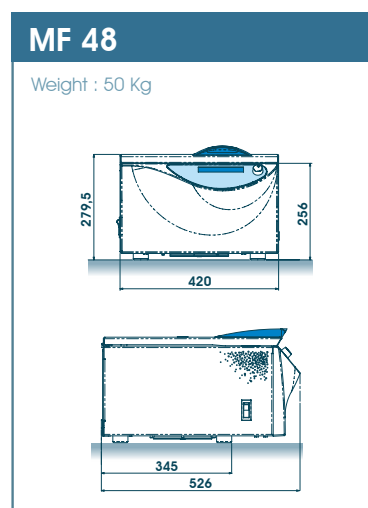

[Accessories]

Ref.	Accessories
30022016	SL-400 Swing-out rotor 4 x 400 ml
30002024	N-400 S buckets for SL-400 swing-out rotor
30002025	BL-400 S lids for N-400S - Set of 4
30002012	Inserts for 13 x 1.5/2 ml microtubes - Set of 4
30002005	Inserts for 14 x 5-7 ml collection tubes - Set of 4
30002009	Inserts for 15 x 5-7 ml BD collection tubes - Set of 4
30002010	Inserts for 19 x 5-7 ml Terumo coll. tubes - Set of 4
30002006	Inserts for 12 x 10 ml collection tubes - Set of 4
30002007	Inserts for 7 x 15 ml conical tubes - Set of 4
30002023	Inserts for 5 x 20 ml tubes - Set of 4
30002011	Inserts for 8 x conical tubes dia. 22 mm - Set of 4
30002014	Inserts for 4 x 50 ml conical tube - Set of 4
30002026	Inserts for 1 x 100 ml tube dia. 52 mm - Set of 4
30002016	Inserts for 1 x 250 ml tube - Set of 4
30002015	Inserts for 1 x 400 ml tube - Set of 4
30022002	SL48-MTP Swing-out rotor for microtitration buckets
30000026	2 Microtitration buckets - capacity 2 x 3 microplates

Ref.	Accessories
30022003	AMF48-32.15 Angle rotor 32 x 15 ml
30022009	AMF48-24 Angle rotor - 24 x 1.5/2 ml (MF 48-R: 20350 xg)
30022012	AMF48-30 Angle rotor - 30 x 1.5/2 ml (MF 48-R: 17990 xg)
30020014	Adaptors for PCR tubes dia. 8 mm - Set of 12
30020017	Adaptors for PCR tubes dia. 6 mm - Set of 12
30022014	AMF 48-PCR Angle rotor - 6 PCR strips (MF 48-R: 17760 xg)
30022006	AMF48-10 Angle rotor - 10 x 10 ml tubes (MF 48-R: 18130 xg)
30022007	AMF48-8 Angle rotor - 8 x 50 ml conical (MF 48-R: 15000 xg)
30020012	Adaptors for 15 ml conical tubes - Set of 8
30020013	Cushions for 50 ml round bottom tubes - Set of 8
30022008	AMF48-6 Angle rotor - 6 x 100 ml (MF 48-R: 15000 xg)



ref. 30002014

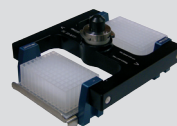

ref. 30022002



ref. 30022007



ref. 30022016



YOUR AWEL PARTNER

