

LAMP

COMPACT 5 W XENON FLASH LAMP MODULES



①: L9455/L9456 series (side-on type) ②: L11035/L11036 series (head-on type) ③: L11316/L11317 series (high output type)
④: L9455 (SMA fiber adapter type) ⑤: L9455/L9456 series (high precision type) ⑥: L9455/L9456 series (silent type)

* SMA fiber is optional (sold separately).

OVERVIEW

Hamamatsu offers compact xenon flash lamp modules containing a 5 W xenon flash lamp along with its power supply and trigger socket. Up to 5 W of energy can be input, which is the maximum among lamp modules of this size. These xenon flash lamp modules also deliver high stability and long service life, making them ideal as a light source for water quality and atmospheric analyzers.

Different types of lamp modules are provided: the L9455/L9456 series side-on type, the L11035/L11036 series head-on type, and the L11316/L11317 series with higher light output twice that of the other lamp modules currently in use.

Also offered are the SMA fiber adapter type, silent type, and high precision type.

APPLICATIONS

- Blood analyzers
- Air pollution analysis
- Microplate readers
- Semiconductor inspection
- Laboratory testing
- Water quality and pollution analysis
- Fluorescence spectrophotometers
- Light sources for image processing

FEATURES

* For more details check the specifications for each series.

- High stability... 1.5 % CV or less
- Long life... 1×10^9 flashes or more
- Compact size
- Repetitive emission frequency... 530 Hz Max.
- Broad radiant spectrum
 - ... Covers from UV to near IR
- Compatible with SMA fibers
 - ... No lens design required
- Silent type
 - ... Audible noise reduced to 1/10 or less
- High precision type
 - ... ± 0.05 mm precision
- Internal EMC noise filter
 - ... Electromagnetic noise reduced to CISPR 11 Class B

Highly stable type for analytical instruments

TYPE NUMBER GUIDE

L9455 - **0 1** - **0 1 1**
 ① ② ③ ④ ⑤ ⑥

L11035 - **0 3** - **0 1** *
 ① ② ③ ④ ⑤ ⑥ *

*④, ⑤ and ⑥ are omitted in case of "0".

① Type No.

Type No.	Arc size	Type	Maximum input
L9455	1.5 mm	Side-on	50 mJ
L9456	3.0 mm		
L11035	1.5 mm	Head-on	50 mJ
L11036	3.0 mm		

* Types with an arc size of 3.0 mm are not available as a module ② with an SMA fiber adaptor.

② Module types

Suffix	Type
0	Standard
1	SMA fiber adaptor
2 *	Silent
4 *	High precision

*: Make to order

③ Main discharge capacitance

Suffix	Capacitance
1	0.22 μF
2	0.11 μF
3	0.047 μF
4	0.28 μF

④ Lamp window material

Suffix	Window material (emission spectral range)
0	UV glass (185 nm to 2000 nm)
1 *	Borosilicate glass (280 nm to 2000 nm)
2 *	Synthetic silica (160 nm to 2000 nm)

*: Make to order

⑤ EMC noise filter

Suffix	Noise filter
0	Not included
1 *	Included

*: Make to order

⑥ Lamp electrode angle (with respect to longitudinal direction of package)

Suffix	Electrode angle
0	0 ° (vertical)
1 *	90 ° (horizontal)

*: Make to order

SPECIFICATIONS

Parameter		L9455 series L11035 series	L9456 series L11036 series	Unit
Arc size		1.5	3.0	mm
Window material		UV glass / borosilicate glass / synthetic silica		—
Spectral range of light output	UV glass	185 to 2000		nm
	Borosilicate glass	280 to 2000		
	Synthetic silica	160 to 2000		
Main discharge voltage variable range *1		400 to 600		V
Main discharge capacitor *2		0.047 / 0.11 / 0.22 / 0.28		μF
Maximum input energy (per flash) *3		See operating condition table.		—
Maximum average input (continuous) *4		5		W
Light output stability (Max.) *5		2.0	1.5	% CV
Guaranteed life *6		1×10 ⁹		flashes
Input voltage range		11 to 28		V
Input current		1		A
Inrush current		4		A
Trigger input		Rectangular wave 5 V to 10 V; pulse width must be 10 μs or more. *7		—
Trigger input impedance		330		Ω
Cooling method		Not required *8		—
Weight (standard type: L9455-01)		Approx. 170		g
Operating ambient temperature		0 to +40		°C
Storage ambient temperature		-40 to +90		°C
Storage ambient humidity		Below 95 *9		% RH
Electromagnetic environmental compatibility	Without noise filter	EN61326-1: 2006 Group 1, Class A		—
	With noise filter	EN61326-1: 2006 Group 1, Class B		

NOTE:

- *1 Internal: Adjustable with variable trimmer.
External: Variable with control voltage from 3.2 V to 4.8 V.
- *2 Installed at time of shipment (refer to the above lineups).
- *3 Maximum lamp input energy (per flash)
 $E = 1/2 CV^2$
E: Maximum lamp input energy (J)
V: Main discharge voltage (V)
C: Main discharge capacitance (F)
- *4 Maximum average lamp input (continuous)
 $W = E \times f$
f: Lamp emission repetition frequency (Hz)
- *5 Light output stability is given by:
Light output stability (% CV) = light output standard deviation / average light output × 100
- *6 At 5 W operation
- *7 Only for external control; synchronized with rising edge.
- *8 Cooling is required when the package temperature exceeds 50 °C during operation.
- *9 No condensation

VIBRATION AND SHOCK RESISTANCE

Resistance to vibration: 5 Hz to 200 Hz, 15 m/s²

Resistance to shock: 500 m/s²

OPERATING CONDITIONS

Type No.	Main discharge capacitor (μF)	Main discharge voltage (V)	Maximum input energy [per flash] (mJ)	Maximum repetition rate (Hz)	Maximum input (W)
L945□ - □1 type L1103□ - □1 type	0.22	400	17.6	284	5.0
		500	27.5	182	5.0
		600	39.6	126	5.0
L945□ - □2 type L1103□ - □2 type	0.11	400	8.8	530	4.7
		500	13.8	362	5.0
		600	19.8	252	5.0
L945□ - □3 type L1103□ - □3 type	0.047	400	3.8	530	2.0
		500	5.9	530	3.1
		600	8.5	530	4.5
L945□ - □4 type L1103□ - □4 type	0.28	400	22.4	223	5.0
		500	35.0	142	5.0
		600	50.4	100	5.0

CHARACTERISTICS

●Light output stability * (typical initial value)

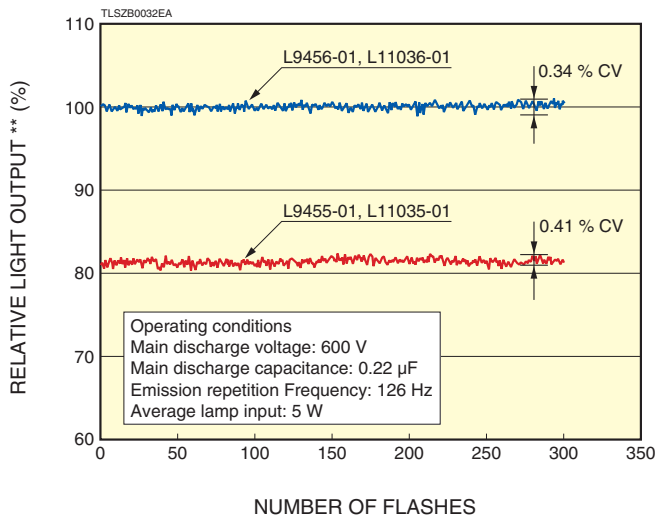

Measurement block diagram

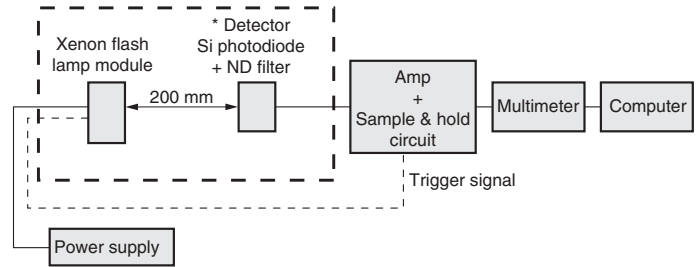

TLSZC0009EA

* Light output stability (% CV) = light output standard deviation / average light output × 100
 ** Output value with average light output of L9456-01 set to 100%.

●Life characteristics

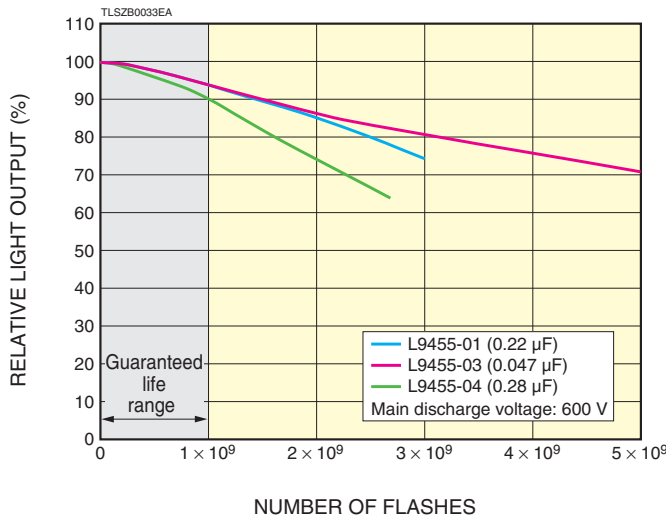

●Emission spectrum (L9455 -01 series)

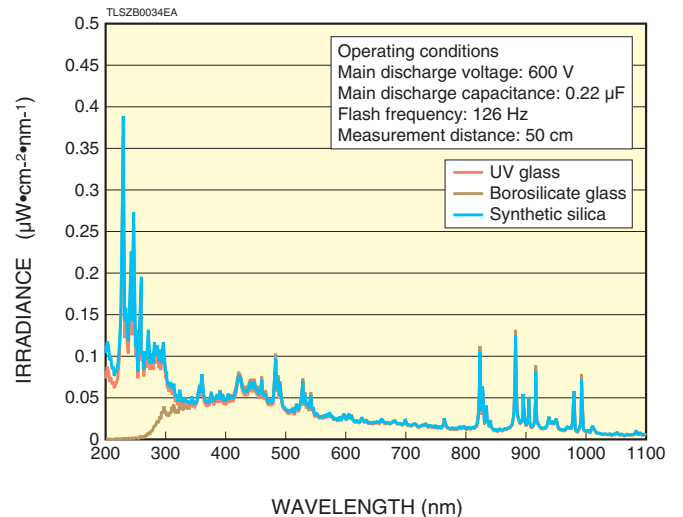

CHARACTERISTICS

● Emission pulse waveform

Waveform difference by arc length

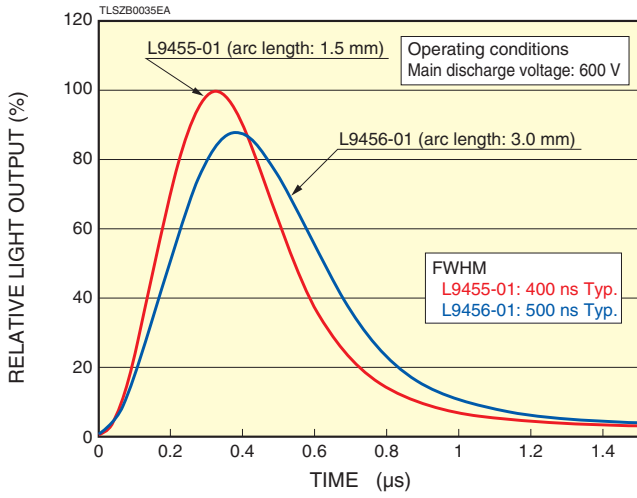

● Emitted light distribution (L9455/L9456 series)

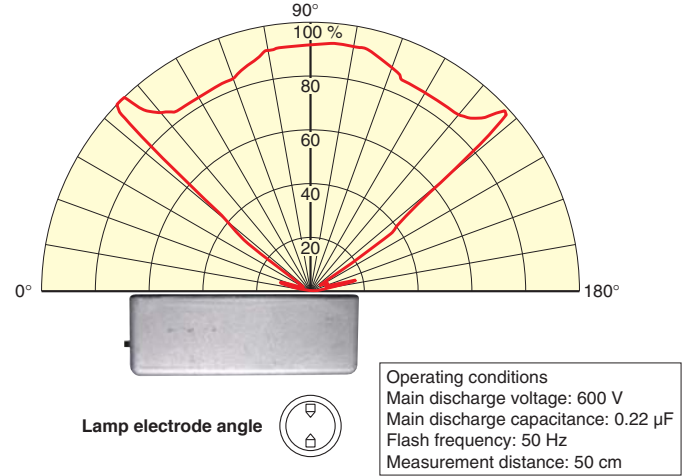

Waveform difference by main discharge capacitance

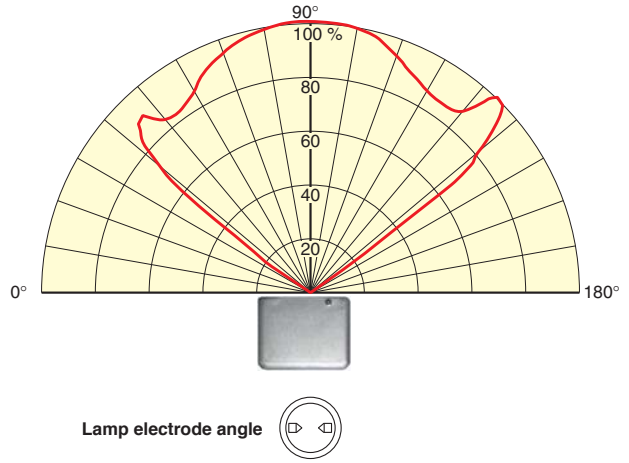
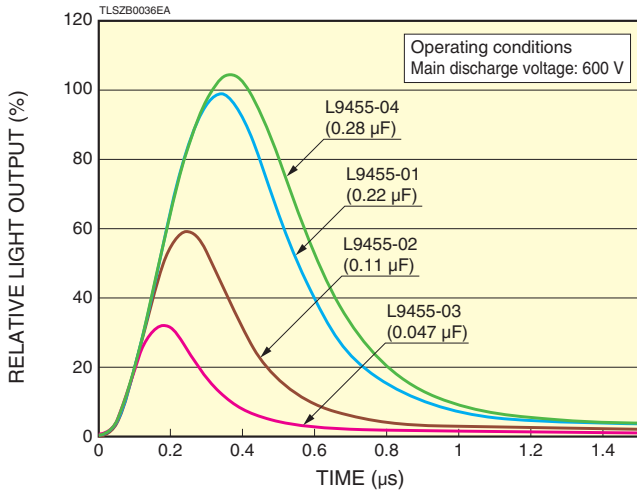

TLSZB0037EA

DIMENSIONAL OUTLINES (unit: mm)

Standard type

● L9455-0□ series, L9456-0□ series

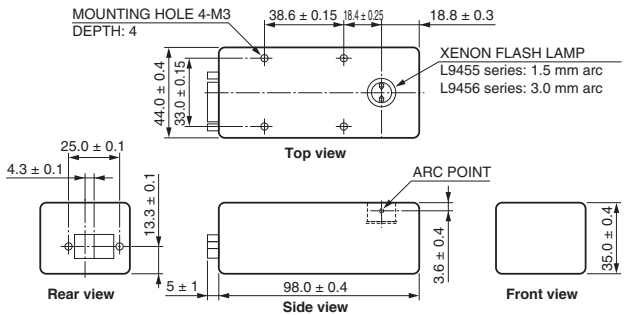

● L11035-0□ series, L11036-0□ series

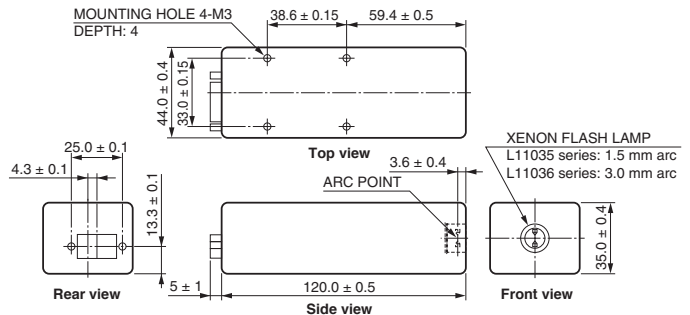

INTERNAL/EXTERNAL SELECTOR SWITCH FOR MAIN DISCHARGE VOLTAGE

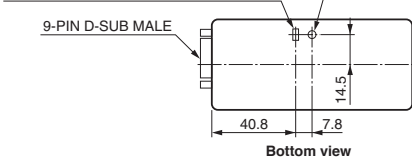

9-pin D-SUB connection

Pin No.	Signal
1	+ input voltage (11 V to 28 V) ^(A)
2	+ input voltage (11 V to 28 V) ^(A)
3	+ main discharge voltage control (3.2 V to 4.8 V)
4	Trigger RTN ^(B)
5	+ trigger input ^(B)
6	Input voltage RTN
7	Input voltage RTN
8	Main discharge voltage control RTN
9	No connection

^(A) Input current: 1 A, Inrush current: 4 A
^(B) Trigger input: 5 V to 10 V rectangular waveform (pulse width: 10 μ s or more)
Package must be grounded, for example, by using an M3 screw for mounting holes.

TLSXA0099EE

INTERNAL/EXTERNAL SELECTOR SWITCH FOR MAIN DISCHARGE VOLTAGE

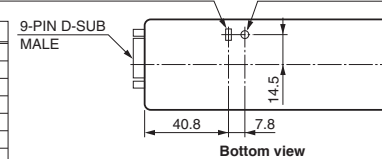

TLSZA0009EB

DIMENSIONAL OUTLINES (unit: mm)

SMA fiber adapter type

●L9455-1□ series

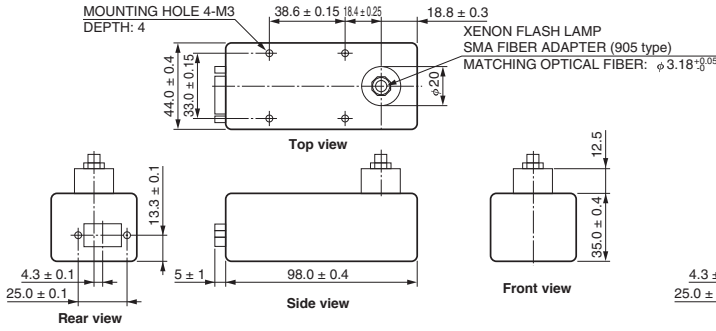

●L11035-1□ series

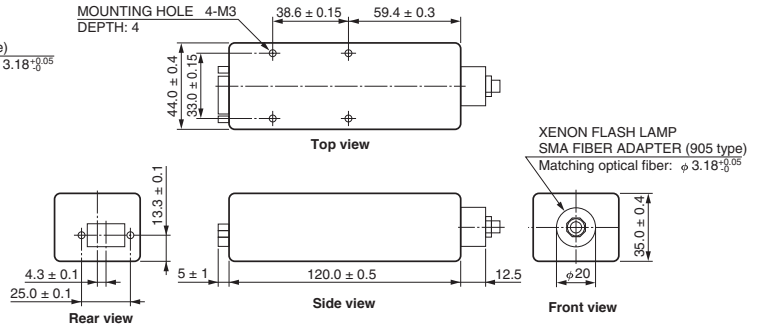

INTERNAL/EXTERNAL SELECTOR SWITCH FOR MAIN DISCHARGE VOLTAGE TRIMMER FOR MAIN DISCHARGE VOLTAGE

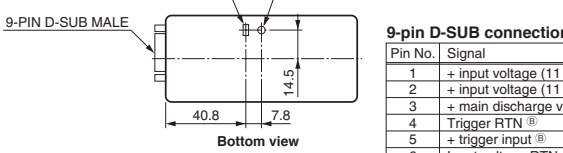

9-pin D-SUB connection

Pin No.	Signal
1	+ input voltage (11 V to 28 V) ^(A)
2	+ input voltage (11 V to 28 V) ^(A)
3	+ main discharge voltage control (3.2 V to 4.8 V)
4	Trigger RTN ^(B)
5	+ trigger input ^(B)
6	Input voltage RTN
7	Input voltage RTN
8	Main discharge voltage control RTN
9	No connection

^(A) Input current: 1 A, Inrush current: 4 A
^(B) Trigger input: 5 V to 10 V rectangular waveform (pulse width: 10 μs or more)
 Package must be grounded, for example, by using an M3 screw for mounting holes.

TLSXA0107ED

TLSZA0010EB

Silent type Emitting points are different.

●L9455-2□ series, L9456-2□ series

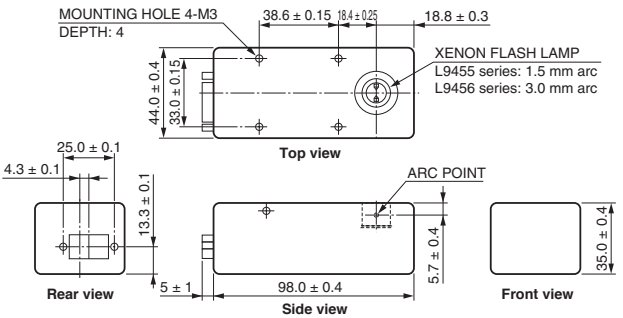

INTERNAL/EXTERNAL SELECTOR SWITCH FOR MAIN DISCHARGE VOLTAGE TRIMMER FOR MAIN DISCHARGE VOLTAGE

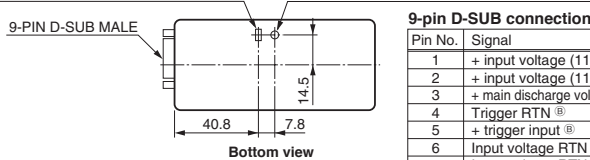

9-pin D-SUB connection

Pin No.	Signal
1	+ input voltage (11 V to 28 V) ^(A)
2	+ input voltage (11 V to 28 V) ^(A)
3	+ main discharge voltage control (3.2 V to 4.8 V)
4	Trigger RTN ^(B)
5	+ trigger input ^(B)
6	Input voltage RTN
7	Input voltage RTN
8	Main discharge voltage control RTN
9	No connection

^(A) Input current: 1 A, Inrush current: 4 A
^(B) Trigger input: 5 V to 10 V rectangular waveform (pulse width: 10 μs or more)
 Package must be grounded, for example, by using an M3 screw for mounting holes.

TLSXA0014EA

●L11035-2□ series, L11036-2□ series

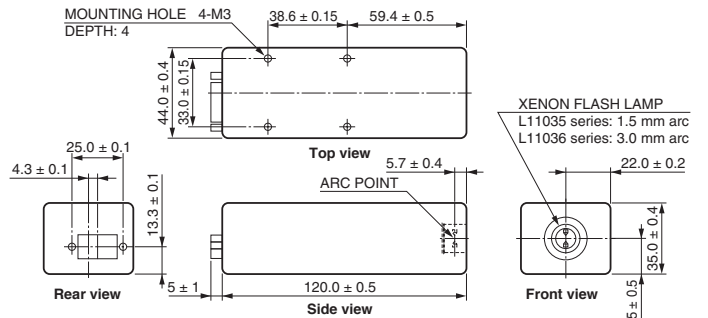

INTERNAL/EXTERNAL SELECTOR SWITCH FOR MAIN DISCHARGE VOLTAGE TRIMMER FOR MAIN DISCHARGE VOLTAGE

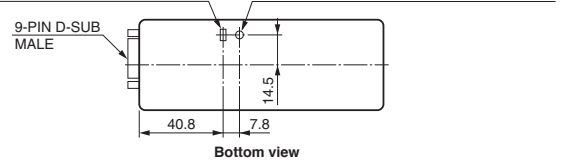

TLSZA0015EA

High precision type Positioning pins are provided in the lamp position.

●L9455-4□ series, L9456-4□ series

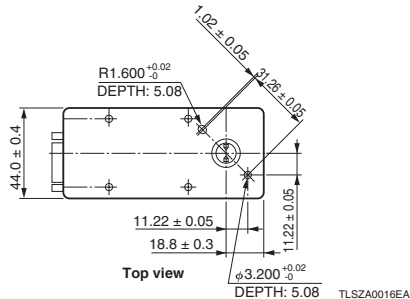

TLSZA0016EA

●L11035-4□ series, L11036-4□ series

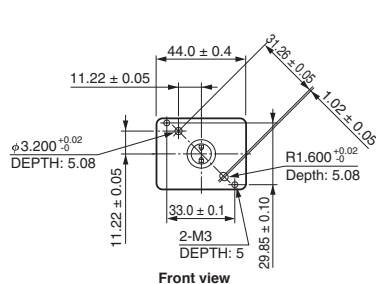

TLSZA0017EA

High output type

TYPE NUMBER GUIDE

L11316 - 4 1 - 0 1 1
 ① ② ③ ④ ⑤ ⑥

L11317 - 0 1 - 1
 ① ② ③ ④ ⑤* ⑥*

*④, ⑤ and ⑥ are omitted in case of "0".

① Type No.

Type No.	Arc size	Type	Maximum input
L11316	1.5 mm	High output	100 mJ
L11317	3.0 mm		

*The L11317 is not available as a module ② with an SMA fiber adapter.

② Module types

Suffix	Type
0	Standard
1	SMA fiber adapter
2 *	Silent
4 *	High precision

*: Make to order

③ Main discharge capacitance

Suffix	Capacitance
1	0.2 μF
2	0.1 μF

④ Lamp window material

Suffix	Window material (emission spectral range)
0	UV glass (185 nm to 2000 nm)
1 *	Borosilicate glass (280 nm to 2000 nm)
2 *	Synthetic silica (160 nm to 2000 nm)

*: Make to order

⑤ EMC noise filter

Suffix	Noise filter
0	Not included
1 *	Included

*: Make to order

⑥ Lamp electrode angle (with respect to longitudinal direction of package)

Suffix	Electrode angle
0	0 ° (vertical)
1 *	90 ° (horizontal)

*: Make to order

SPECIFICATIONS

Parameter	L11316 series	L11317 series	Unit
Arc size	1.5	3.0	mm
Window material	UV glass / borosilicate glass / synthetic silica		—
Spectral range of light output	UV glass	185 to 2000	nm
	Borosilicate glass	280 to 2000	
	Synthetic silica	160 to 2000	
Main discharge voltage	Internal	650 to 1000	V
Main discharge voltage variable range *1	External	500 to 1000	
Main discharge capacitance *2	0.1 / 0.2		μF
Maximum input energy (per flash) *3	See operating condition table.		J
Maximum average input (continuous) *4	5		W
Light output stability (Max.) *5	3.0	2.5	% CV
Guaranteed life *6	5 × 10 ⁸		flashes
Input voltage range	21.6 to 26.4		V
Input current	0.75		A
Inrush current	3		A
Trigger input	Rectangular waveform 5 V to 10 V; pulse width must be 10 μs or more *7		—
Trigger input impedance	330		Ω
Cooling method	Not required *8		—
Mass (standard type: L11316-01)	Approx. 560		g
Operating ambient temperature	0 to +40		°C
Storage ambient temperature	-40 to +90		°C
Storage ambient humidity	Below 95 *9		% RH
Electromagnetic environmental compatibility	Without noise filter	EN61326-1: 2006 Group 1, Class A	
	With noise filter	EN61326-1: 2006 Group 1, Class B	

NOTE:

- *1 Internal: Adjustable with variable trimmer.
External: Variable with control voltage from 2.44 V to 4.88 V.
- *2 Installed at time of shipment (refer to the above lineups).
- *3 Maximum lamp input energy (per flash)
E=1/2 CV²
E: Maximum lamp input energy (J)
V: Main discharge voltage (V)
C: Main discharge capacitance (F)
- *4 Maximum average lamp input (continuous)
W=E × f
f: Lamp emission repetition frequency (Hz)
- *5 Light output stability is given by:
Light output stability (% CV) = light output standard deviation / average light output × 100
- *6 At 5 W operation
- *7 Only for external control; synchronized with rising edge.
- *8 Cooling is required when the package temperature exceeds 50 °C during operation.
- *9 No condensation

VIBRATION AND SHOCK RESISTANCE

Resistance to vibration: 5 Hz to 200 Hz, 15 m/s²

Resistance to shock: 500 m/s²

OPERATING CONDITIONS

Type No.	Main discharge capacitor (μF)	Main discharge voltage (V)	Maximum input energy [per flash] (mJ)	Maximum repetition rate (Hz)	Maximum input (W)
L1131□-□1 type	0.2	500	25.0	200	5.0
		700	49.0	102	5.0
		1000	100.0	50	5.0
L1131□-□2 type	0.1	500	12.5	400	5.0
		700	24.5	204	5.0
		1000	50.0	100	5.0

CHARACTERISTICS

●Emission pulse waveform

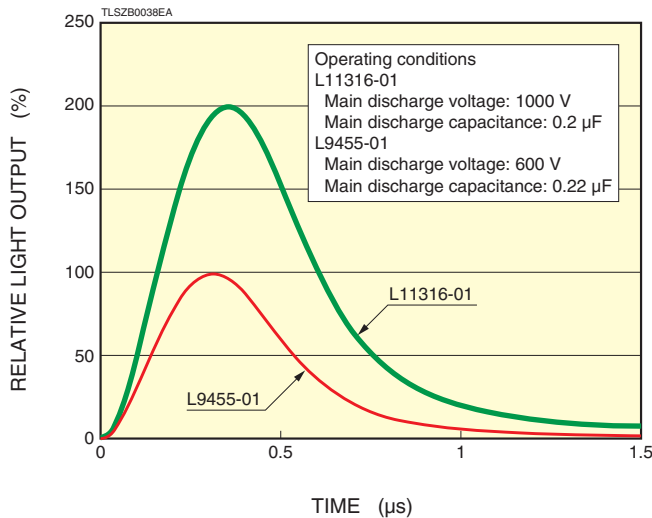

●Life characteristics (L11316-01)

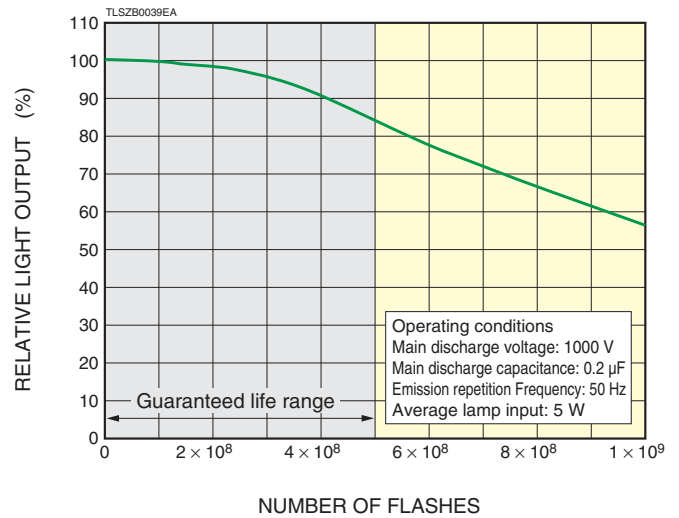

DIMENSIONAL OUTLINES (unit: mm)

Standard type

●L11316-0□ series, L11317-0□ series

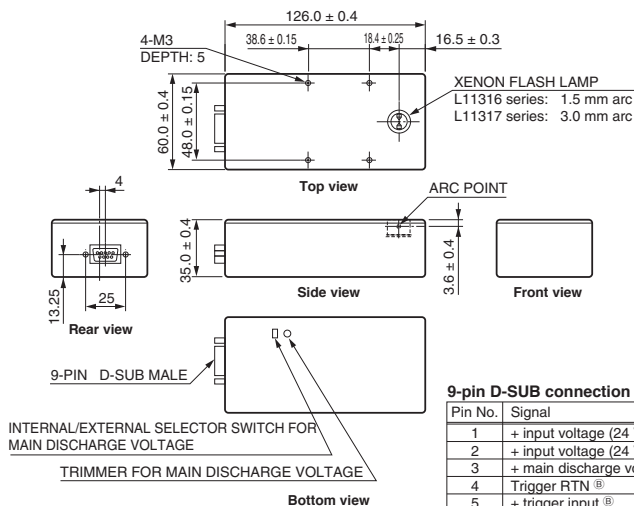

9-pin D-SUB connection

Pin No.	Signal
1	+ input voltage (24 V ± 2.4 V) ^(A)
2	+ input voltage (24 V ± 2.4 V) ^(A)
3	+ main discharge voltage control (2.44 V to 4.88 V)
4	Trigger RTN ^(B)
5	+ trigger input ^(B)
6	Input voltage RTN
7	Input voltage RTN
8	Main discharge voltage control RTN
9	No connection

^(A) Input current: 0.75 A, Inrush current: 3 A

^(B) Trigger input: 5 V to 10 V rectangular waveform (pulse width: 10 ms or more)

Package must be grounded, for example, by using an M3 screw for mounting holes.

TLSZA0018EA

SMA fiber adapter type

●L11316-1□ series

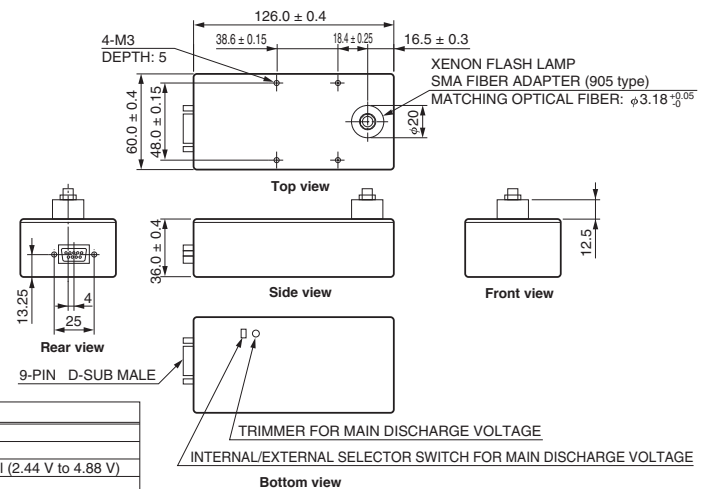

TLSZA0019EA

DIMENSIONAL OUTLINES (unit: mm)

Silent type Emitting points are different.

●L11316-2□ series, L11317-2□ series

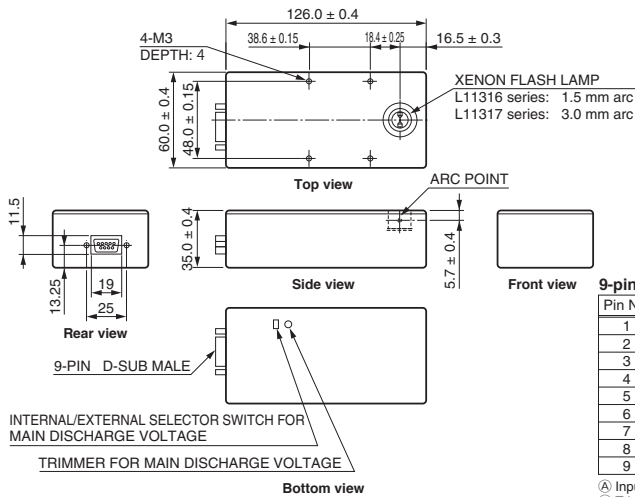

TLSZA0020EA

High precision type

●L11316-4□ series, L11317-4□ series

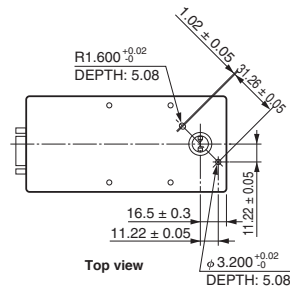

TLSZA0021EA

9-pin D-SUB connection

Pin No.	Signal
1	+ input voltage (24 V ± 2.4 V) [Ⓐ]
2	+ input voltage (24 V ± 2.4 V) [Ⓐ]
3	+ main discharge voltage control (2.44 V to 4.88 V)
4	Trigger RTN [Ⓑ]
5	+ trigger input [Ⓒ]
6	Input voltage RTN
7	Input voltage RTN
8	Main-discharge-voltage control RTN
9	No connection

[Ⓐ] Input current: 0.75 A, Inrush current: 3 A

[Ⓑ] Trigger input: 5 V to 10 V rectangular waveform (pulse width: 10 ms or more)

Package must be grounded, for example, by using an M3 screw for mounting holes.

RELATED PRODUCTS

■UV-resistant light guide (sold separately)

These light guides have SMA905 optical fiber connectors at both ends and are designed to minimize loss of UV transmittance. On synthetic silica lamp modules, use the A11691-06AS as a light guide.

Dimensional outline (unit: mm)

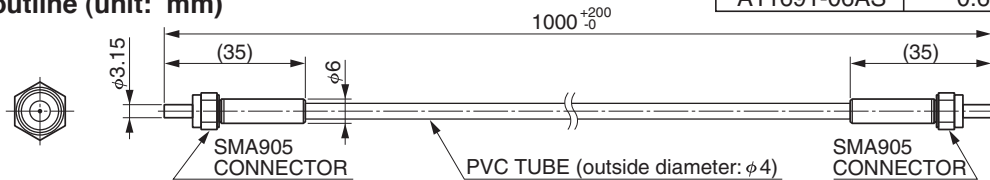

TLSZA0021EA

Type No.	Core diameter	Length
A7969-06AS	0.6 mm	1.0 m
A7969-08AS	0.8 mm	
A11691-06AS	0.6 mm	

■Shield cable with D-sub input connector A11690 (sold separately)

Besides grounding the module case, properly shielding the cable is important to reduce noise in xenon flash lamp modules. The A11690 is a shielded cable with a D-sub input connector that is extremely effective in reducing noise. Standard cable length is 300 mm but other lengths are available on request. Please consult our sales office if needed.

Dimensional outline (unit: mm)

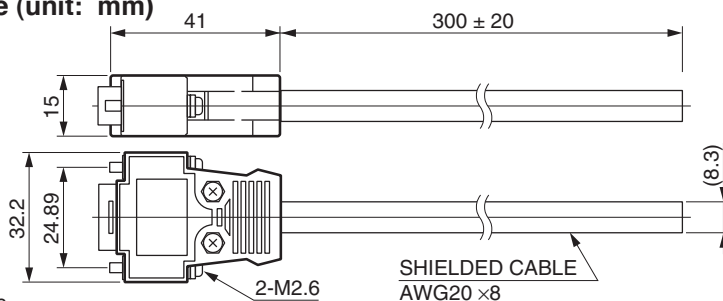

1. Brown : + input voltage
2. Red : + input voltage
3. Blue : + main discharge voltage control
4. Yellow : Trigger RTN
5. Green : + trigger input
6. White : Input voltage RTN
7. Black : Input voltage RTN
8. Gray : Main-discharge-voltage control RTN

* Patent pending; 2 patents

TLSZA0023EA

Subject to local technical requirements and regulations, availability of products included in this promotional material may vary. Please consult with our sales office. Information furnished by HAMAMATSU is believed to be reliable. However, no responsibility is assumed for possible inaccuracies or omissions. Specifications are subject to change without notice. No patent rights are granted to any of the circuits described herein. ©2013 Hamamatsu Photonics K.K.

HAMAMATSU PHOTONICS K.K. www.hamamatsu.com

HAMAMATSU PHOTONICS K.K., Electron Tube Division

314-5, Shimokanzo, Iwata City, Shizuoka Pref., 438-0193, Japan, Telephone: (81)539/62-5248, Fax: (81)539/62-2205

U.S.A.: Hamamatsu Corporation: 360 Foothill Road, P. O. Box 6910, Bridgewater, N.J. 08807-0910, U.S.A., Telephone: (1)908-231-0960, Fax: (1)908-231-1218 E-mail: usa@hamamatsu.com

Germany: Hamamatsu Photonics Deutschland GmbH: Arzbergerstr. 10, D-82211 Herrsching am Ammersee, Germany, Telephone: (49)8152-375-0, Fax: (49)8152-2658 E-mail: info@hamamatsu.de

France: Hamamatsu Photonics France S.A.R.L.: 19, Rue du Saule Trapu, Parc du Moulin de Massy, 91882 Massy Cedex, France, Telephone: (33)1 69 53 71 00, Fax: (33)1 69 53 71 10 E-mail: infos@hamamatsu.fr

United Kingdom: Hamamatsu Photonics UK Limited: 2 Howard Court, 10 Tewin Road Welwyn Garden City Hertfordshire AL7 1BW, United Kingdom, Telephone: 44-(0)1707-294888, Fax: 44(0)1707-325777 E-mail: info@hamamatsu.co.uk

North Europe: Hamamatsu Photonics Norden AB: Thorshamnsgatan 35 SE-164 40 Kista, Sweden, Telephone: (46)8-509-031-00, Fax: (46)8-509-031-01 E-mail: info@hamamatsu.se

Italy: Hamamatsu Photonics Italia: S.R.L.: Strada della Moia, 1/E, 20020 Arese, (Milano), Italy, Telephone: (39)02-935 81 733, Fax: (39)02-935 81 741 E-mail: info@hamamatsu.it

China: Hamamatsu Photonics (China) Co., Ltd.: 1201 Tower B, Jiaming Center, 27 Dongsanhuan Road North, Chaoyang District, Beijing 100020, China, Telephone: (86)10-6586-6006, Fax: (86)10-6586-2866 E-mail: hpc@hamamatsu.com.cn

TLSZ1006E02
AUG. 2013 IP