

Bruker Elemental



Q8 MAGELLAN

- High-end stationary vacuum spectrometer

think forward

OES

The Evolution of Perfection

Engineered for ultimate spark spectrometry

The genes are right: Q8 MAGELLAN is a well reputed, true high-end spark spectrometer with clear concepts! It has taken the lead in many applications being the only vacuum-spectrometer featuring channel-photomultipliers, digital plasma generator, unlimited single-spark- and time resolution and a heavy duty, low-maintenance spark stand with co-axial argon flow. All ingredients to define the perfect metals analyzer.

The new Q8 MAGELLAN is the consistent continuation of this development and marks a (r)evolutionary milestone in optical emission spectroscopy.

Next Step to perfection

Q8 MAGELLAN now offers - besides well established technologies - additional innovations and benefits:

- improved optical properties
- enhanced analytical capabilities
- extended maintenance intervals
- auto-profile check for secured long-term stability
- one-button operation for quick and easy handling
- new instrument design
- simplified servicing

The new Q8 MAGELLAN is the perfect symbiosis of approved and new, tradition and innovation.

Steel plants and other demanding metal industries require high-performance spark spectrometers



The new matrix: QMatrix

With Q8 MAGELLAN you can perform an analysis without touching the mouse or keyboard! But once you find out about the possibilities offered, and how simple it is to use, you never want to miss it again!

The analysis desktop of QMatrix does not only give you the results, average, and statistics but also colour information about the compliance of your sample with a given specification. The grade library offers internal/external limits, reference to international norms, a version control, and a quick find option.

The calibration software provides secure access to all calibration information. The same programme is used during factory calibration and provides a full list of features from regression wizard to auto-calculation of inter-element effects.

For post-analytical data treatment the SQL database application provides everything needed. From archive to statistics, filters, views, reporting, Office export, AuditTrail and much more.

At your service



Although each Q8 MAGELLAN has an integrated webserver and you could easily use remote online support, we also like to talk to you personally. Call our local service or the headquarter in Germany. We will be pleased to assist you with all the questions you may have around your Q8 MAGELLAN.

QMatrix - spectrometer software

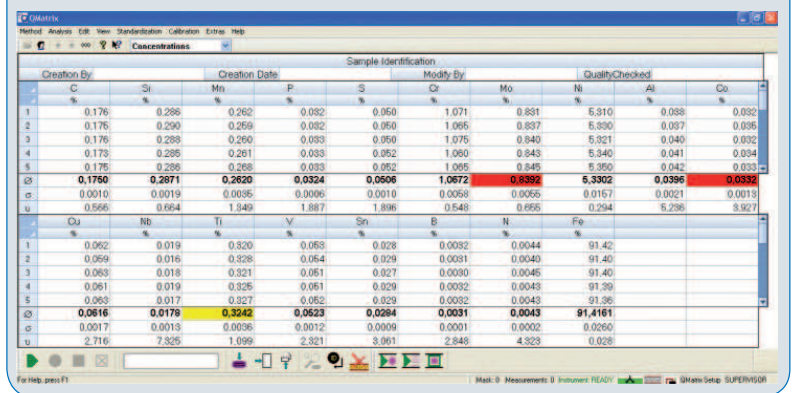

From running measurements to auto-averaging, coloured quality control display, e-mail results, to setting up TRS and visualize single sparks: individual user level definitions give every user what he needs.

QMatrix Reg - calibration software

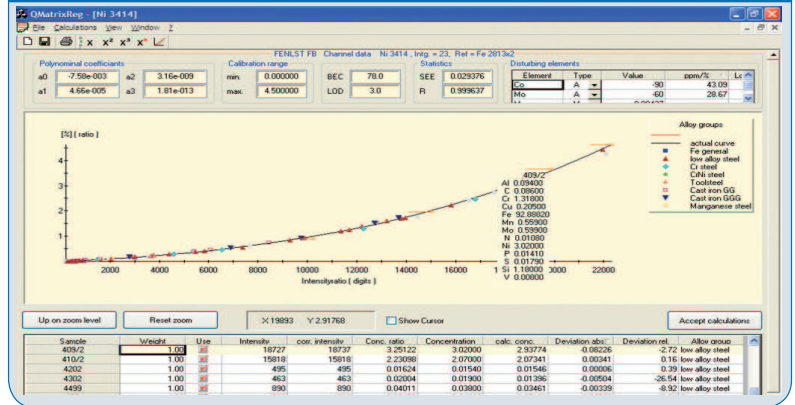

Thanks to the perfect factory calibration of your system, most customers are not using the comprehensive calibration software.

Analyses database

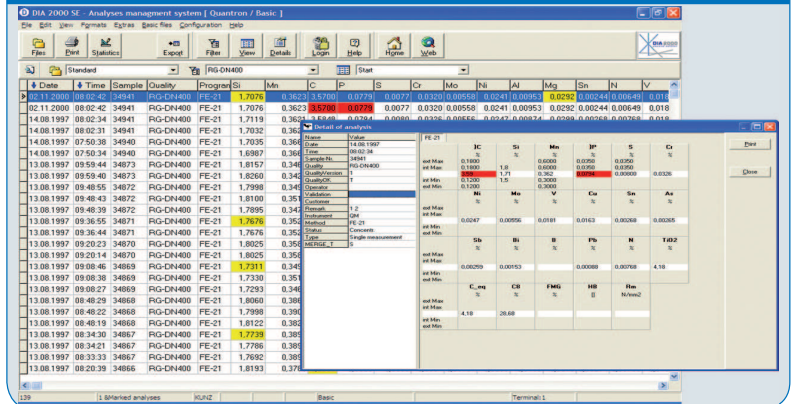

The SQL database application is fast and safe. A comfortable tool for all your post-analytical data treatment demands. With its networking capabilities you may see what's going on at the instrument from any PC in your network.

● Applying applications

The devil is in the details

... and this is why our engineers have looked into every single of them. With surprising results: ease of operation with a pneumatic sample clamp, a self-centering plate, or the possibility to perform an analysis without touching mouse or keyboard. And many more are there to discover...

A sense of fresh air in the spark stand - new co-axial argon flow

The new co-axial argon flow represents the culmination of our efforts to further improve performance. It focuses the argon directly on the burnspot, where it is needed. This allows to use ArgonStop[®], a function to switch off argon flow during stand-by, saving on gas consumption, reducing start-up phase of the instrument, and finally dramatically improving the analytical performance especially on small samples and thin wires. A new flow cycle spring-cleans the chamber, allowing you in many matrices to run thousands of samples without opening the spark stand plate.

Spark Stand with co-axial argon flow

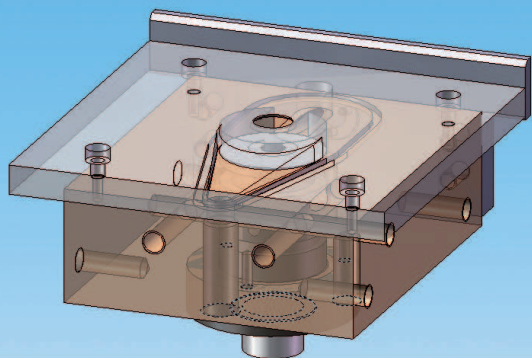

New co-axial spark stand: reduces gas consumption, extends cleaning intervals, and improves analytical performance!



Q8 MAGELLAN covers any application: from primary metal production to metal processing, incoming material testing, etc. From Arsenic to Zirconium, from sub-ppm to percentage levels. Magellan meets complex requirements.

Your application in focus

Single or multi-base applications, trace analysis or alloys, Q8 MAGELLAN can be configured for virtually any metal analysis requirement. With up to 128 channels and widest Rowland segment it combines high flexibility with the proven advantages of a single optic vacuum system.

Prepared for tomorrow's needs

A vast choice of applications is available for Q8 MAGELLAN. During factory calibration internationally certified standards are individually sparked on every instrument. An expert evaluates the data to ensure highest accuracy and analytical quality.

For more exotic requirements a team of application specialists help to develop new methods to meet your needs.

The new and extended features of Q8 MAGELLAN offer improved results on known analytical tasks and open new fields of applications.

There are no problems, but challenges!

Innovative technologies

Working principle of CPMs

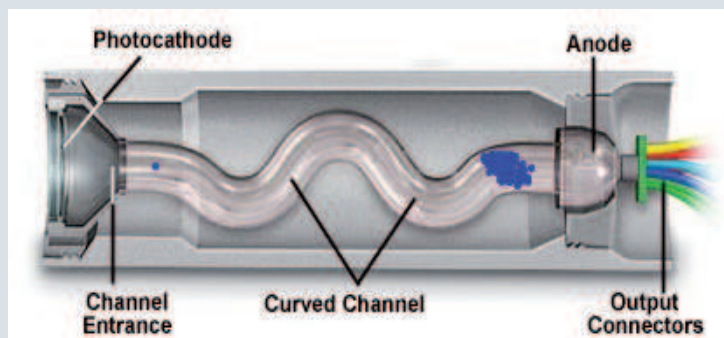

The working principle of a channel photomultiplier. Similar to the classical PMT, but with enhanced properties, photons are converted into electrons and highly multiplied. The reading at the anode gives the light intensity in „digits“.

Channel photomultiplier (CPM) & Readout



To take advantage from the outstanding features of the channeltron detectors high-speed read-out with extremely low electronic noise is required.

Benefits

See how your investment into Q8 MAGELLAN will quickly pay back:

- low detection limits due to CPM+TRS+digital source+++
- innovative analytical techniques
- simple, yet comprehensive software package including spectrometer software, calibration, SQL database
- long service & maintenance intervals due to AutoCleaning
- low operation costs due to Argon Stop®
- excellent long-term stability
- innovative service concept with online support and preventive maintenance
- low Total Cost of Ownership (TCO)

Let's face the facts !

Photomultipliers are the first choice detectors for demanding metal applications. And the channel photomultiplier (CPM) by far outperforms the bulb-type photomultiplier tubes (PMT)! Higher dynamic range, highest sensitivity, extremely low dark current counts are its key features. This makes it the ideal detector for all sorts of metal applications from high concentrations to sub-ppm traces. At the same time, it requires less space in the optical system and has a robust, simple design. Switch it on and it is instantly stable, no warming-up time required. Even strong magnetic fields hardly affect the gain. Designed for decades of high performance.

But the detector is only one component in an optical system. In order to benefit most from the CPM we have optimised our vacuum optic: due to a re-designed exit slit, refractors could be banned; a new mounting concept makes optical assembly fast and allows for simple line additions. The small CPMs combined with an extended Rowland segment gives the best wavelength coverage in this instrument category.

Together they're strong !

A fast and sensitive detector requires an equally powerful read-out. You could read about important benchmarks on page one already. All these help to provide you with lower detection limits, improved precision, outstanding long-term stability, and a long system lifetime. The single-spark detection improves performance by statistical means, allows for new algorithms for soluble/insoluble determination, helps to quantify inclusions, and many more innovative analytical techniques.

A digital, maintenance-free source generator helps to create a stable plasma. This allows for synchronisation with the read-out and, thus, to make use of time-resolved-spectroscopy. Source parameter can be software optimised to hit the best excitation potential of an analyte.

Unlimited, free combination of all excitation and read-out parameters offer unseen opportunities to revolutionize the analytical performance of many applications.

Get to see a Q8 MAGELLAN soon and find out, how it can solve your analytical challenges.

Technical specifications



Electrical data

- 230 V -15 % / +10 % or 115 V -15 % / +10 % (50/60 Hz)
- 950 W during measurement, 350 W standby
- 16 A slow blow fuse or 25 A slow blow fuse

Weights & Dimensions

970 x 1050 x 1350 mm / 38 x 41 x 53" (W x H x D)
Weight ~ 660 lbs. / 300 kg

Optical system

- Paschen Runge / 750 mm
- Wavelength range: 110 nm – 800 nm
- Channel photomultiplier detectors
 - Highest anode sensitivity
 - Very stable and low dark current
- Up to 128 analytical channels
- Single vacuum optic

Read-out system

- Time-resolved reading of single sparks
 - Individually settable integration windows for all analytical channels with simultaneous acquisition of each single spark
- Scalable and microprocessor controlled read-out system
 - Use of modern and programmable electronics for time-critical jobs
 - Integrators are matched to detector characteristics
 - High-quality PCI data recording board with a sampling rate up to 250 kHz

Instrument control

- Communication
 - Use of Ethernet and TCP/IP between PC and instrument as well as for all instrument internal communication

Source

- Digital generation of any discharge current curve through programmable logic modules
 - Integrated emergency stop
- Maintenance-free, inductive ignition
- Discharge time 10 μ s to 2 ms
 - max. 200 A peak current
 - max. 1000 Hz spark sequence

Software

- Analysis software with integrated single spark evaluation
 - Material quality monitoring with dynamic internal and external limit check
 - Material identification of unknown samples
- Analysis management
 - Integrated analysis management using SQL data base
 - Storage, sorting, filtering, display, searching, printing, archival
 - Comprehensive statistic evaluation, SPC charts (option), certificate
- Email supported reporting system
- Integrated systems for diagnosis and maintenance via internet or telephone
 - provide efficient service at short term

*CPM working principle graphics by courtesy of Olympus Corp.,
Windows is a registered trademark of Microsoft Corp.

● Bruker Elemental GmbH

Kastellstrasse 31-35
47546 Kalkar, Germany
Tel. +49 (2824) 97650-0
Fax +49 (2824) 97650-10
info@bruker-elemental.com
www.bruker-elemental.com

Bruker AXS Inc.

40 Manning Road
Billerica, MA 01821, USA
Tel. +1 (978) 663-3660
Fax +1 (978) 667-5993
oes@bruker-axs.com
www.bruker-axs.com