

Blackfly™



UNBEATABLE VALUE + ULTRA-COMPACT + POE

- World's smallest POE GigE Vision camera: 29x29x30mm
- Starting at \$295/ €219 (single quantities)
- On-camera image processing: color interpolation, gamma, and LUT
- 16 MByte frame buffer; LED status indicator

The Blackfly camera line combines Power over Ethernet, industry-leading affordability and a host of unique features for uncompromising value. Every Blackfly model comes packed with functionality designed to maximize performance and reliability, including a 16 MByte frame buffer; LED status indicators; and an on-camera image processing pipeline that provides color interpolation, gamma, and lookup table functionality. The Blackfly camera weighs just 36 grams, measures 29x29x30mm and uses 2 watts of power.

Model	Version	MP	Imaging Sensor
BFLY-PGE-03S2C-CS BFLY-PGE-03S2M-CS	Color Mono	0.3 MP	<ul style="list-style-type: none"> ■ Sony ICX424, 1/3", 7.4 μm ■ Global shutter ■ 84 FPS at 648 x 488
BFLY-PGE-03S3C-CS BFLY-PGE-03S3M-CS	Color Mono	0.3 MP	<ul style="list-style-type: none"> ■ Sony ICX414, 1/2", 9.9 μm ■ Global shutter ■ 90 FPS at 648 x 648
BFLY-PGE-05S2C-CS BFLY-PGE-05S2M-CS	Color Mono	0.5 MP	<ul style="list-style-type: none"> ■ Sony ICX693, 1/3", 6.0 μm ■ Global shutter ■ 50 FPS at 808 x 608
BFLY-PGE-09S2C-CS BFLY-PGE-09S2M-CS	Color Mono	0.9 MP	<ul style="list-style-type: none"> ■ Sony ICX692, 1/3", 4.08 μm ■ Global shutter ■ 30 FPS at 1288 x 728
BFLY-PGE-12A2C-CS BFLY-PGE-12A2M-CS	Color Mono	1.2 MP	<ul style="list-style-type: none"> ■ Aptina AR0134, 1/3", 3.75 μm ■ Global shutter ■ 52 FPS at 1280 x 960
BFLY-PGE-13E4C-CS BFLY-PGE-13E4M-CS	Color Mono	1.3 MP	<ul style="list-style-type: none"> ■ e2v EV76C560, 1/1.8", 5.3 μm ■ Global shutter ■ 60 FPS at 1280 x 1024
BFLY-PGE-13S2C-CS BFLY-PGE-13S2M-CS	Color Mono	1.3 MP	<ul style="list-style-type: none"> ■ Sony ICX445, 1/3", 3.75 μm ■ Global shutter ■ 22 FPS at 1288 x 964
BFLY-PGE-14S2C-CS	Color	1.3 MP	<ul style="list-style-type: none"> ■ Sony IMX104, 1/3", 3.75 μm ■ Rolling shutter ■ 60 FPS at 1296 x 1032
BFLY-PGE-20E4C-CS BFLY-PGE-20E4M-CS	Color Mono	2.0 MP	<ul style="list-style-type: none"> ■ e2v EV76C570, 1/1.8", 4.5 μm ■ Global shutter ■ 47 FPS at 1600 x 1200
BFLY-PGE-23S2C-CS	Color	2.3 MP	<ul style="list-style-type: none"> ■ Sony IMX136, 1/2.8", 2.8 μm ■ Rolling shutter ■ 27 FPS at 1920 x 1200
BFLY-PGE-23S6C-C BFLY-PGE-23S6M-C	Color Mono	2.3 MP	<ul style="list-style-type: none"> ■ Sony IMX249, 1/1.2", 5.86 μm ■ Global shutter ■ 41 FPS at 1920 x 1200
BFLY-PGE-50A2C-CS BFLY-PGE-50A2M-CS	Color Mono	5.0 MP	<ul style="list-style-type: none"> ■ Aptina MT9P006/Aptina MT9P031, 1/2.5", 2.2 μm ■ Rolling Shutter with Global Reset ■ 13 FPS at 2592 x 1944
BFLY-PGE-50H5C-C BFLY-PGE-50H5M-C	Color Mono	5.0 MP	<ul style="list-style-type: none"> ■ Sharp RJ32S3AA0DT, 2/3", 3.45 μm ■ Global shutter ■ 7.5 FPS at 2448 x 2048

Imaging Performance (EMVA 1288)	See the Imaging Performance Specification , which includes quantum efficiency, saturation capacity (full well depth), read noise, dynamic range and signal to noise ratio.
A/D Converter	10-bit BFLY-PGE-13E4/BFLY-PGE-20E4; 10- and 12-bit BFLY-PGE-23S6; 12-bit all others
Video Data Output	8, 12, 16 and 24-bit digital data
Image Data Formats	Mono8, Mono12, Mono16, Raw8, Raw12, Raw16 (all models); RGB, YUV411, YUV422, YUV 444 (color models)
Partial Image Modes	Pixel binning, decimation, and region of interest (ROI) modes
Image Processing	Gamma, lookup table, hue, saturation, and sharpness
Shutter	Global shutter; Rolling shutter (BFLY-PGE-14S2/BFLY-PGE-23S2/BFLY-PGE-50A2); Automatic*/manual/one-push* (**free running only for CMOS)
Gain	Up to 32 seconds (1 second BFLY-PGE-12A2/BFLY-PGE-13E4/BFLY-PGE-20E4; 3.9 seconds BFLY-PGE-23S6)
Gamma	Automatic*/manual/one-push* (**free running only for CMOS)
White Balance	-10.104 dB to 23.991 dB (BFLY-PGE-03S2); -8.728 dB to 23.991 dB (BFLY-PGE-03S3); 0 dB to 24 dB (BFLY-PGE-05S2/BFLY-PGE-20E4); -4.5 dB to 24 dB (BFLY-PGE-09S2); 0 dB to 18 dB (BFLY-PGE-13E4/BFLY-PGE-50A2); -5.753 dB to 13 dB (BFLY-PGE-12A2); -1.5 dB to 40.5 dB (BFLY-PGE-14S2); 0 dB to 29.996 dB (BFLY-PGE-23S6); -6.234 dB to 23.991 dB (BFLY-PGE-50H5)
High Dynamic Range	Not supported
Color Processing	On-camera in YUV or RGB format, or on-PC in Raw format
Digital Interface	Gigabit Ethernet interface with screw locks for camera control and data; Power over Ethernet
Transfer Rates	10/100/1000 Mbit/s
GPIO	6-pin Hirose HR10A-7R-6PB GPIO connector for trigger, strobe, and power
External Trigger Modes	Standard, bulb (BFLY-PGE-03S2/BFLY-PGE-03S3/BFLY-PGE-13S2/BFLY-PGE-14S2/BFLY-PGE-23S2/BFLY-PGE-23S6/BFLY-PGE-50A2/BFLY-PGE-50S5), low smear (BFLY-PGE-03S2/BFLY-PGE-03S3/BFLY-PGE-05S2/BFLY-PGE-09S2/BFLY-PGE-13S2/BFLY-PGE-50H5), overlapped (BFLY-PGE-03S2/BFLY-PGE-03S3/BFLY-PGE-05S2/BFLY-PGE-09S2/BFLY-PGE-13S2/BFLY-PGE-23S6/BFLY-PGE-50S5), multi shot
Image Buffer	16 MB frame buffer
Memory Channels	2 user configuration sets for custom camera settings
Flash Memory	512 KB non-volatile memory
Dimensions	29 mm x 29 mm x 30 mm excluding lens holder, without optics (metal case)
Mass	36 grams (without optics)
Power Consumption	Power over Ethernet (PoE); or 12 V nominal (5 - 16 V) via GPIO interface, maximum 2.5 W (2 W BFLY-PGE-13E4)
Machine Vision Standard	GigE Vision v1.2
Camera Control	Via FlyCapture SDK or GigE Vision third party software
Camera Updates	In-field firmware updates
Lens Mount	CS-mount (C-mount BFLY-PGE-23S6/BFLY-PGE-50H5) (5 mm C-mount adapter not included)
Temperature	Operating: 0° to 45°C; Storage: -30° to 60°C
Humidity	Operating: 20 to 80% (no condensation); Storage: 20 to 95% (no condensation)
Compliance	CE, FCC, RoHS
Operating System	Windows, Linux (32- and 64-bit)
Warranty	3 years

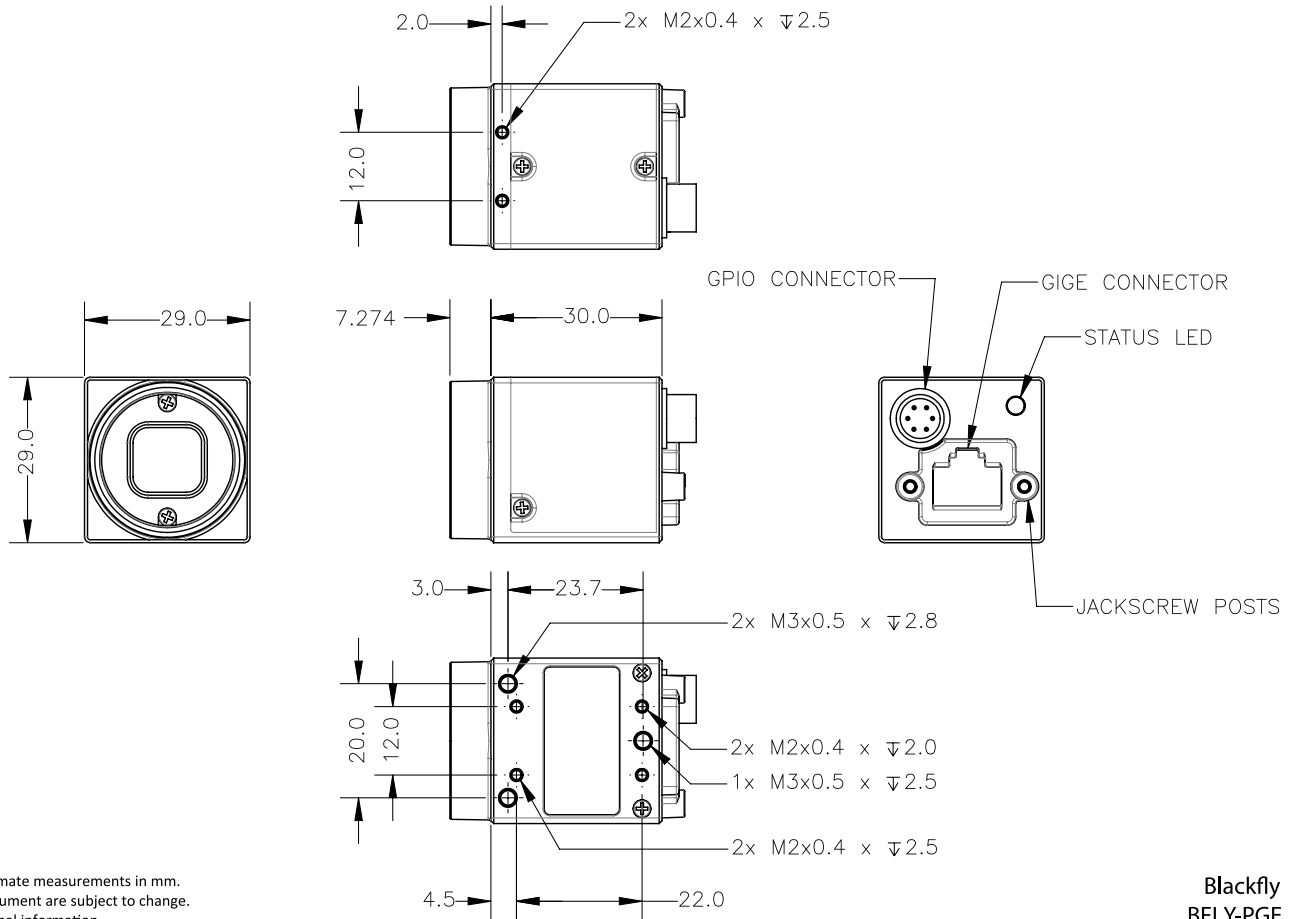

Dimensions are approximate measurements in mm.
The contents of this document are subject to change.
For questions or additional information,
contact support@ptgrey.com

Blackfly
BFLY-PGE
Copyright 2012
Point Grey Research Inc.
All rights reserved.
Revised: 2012/11/14



CANADA (Headquarters)

Point Grey Research, Inc.

12051 Riverside Way
Richmond, BC, Canada
V6W 1K7

T: +1 866.765.0827 (toll free)
T: +1 604.242.9937
F: +1 604.242.9938
E: sales@ptgrey.com

www.ptgrey.com
www.ptgreystore.com

USA

T: +1 866.765.0827 (toll free)
E: na-sales@ptgrey.com

EUROPE

T: +49 7141 488817-0
F: +49 7141 488817-99
E: eu-sales@ptgrey.com

CHINA

T: +86 10 8215 9938
F: +86 10 8215 9936
E: chinasales@ptgrey.com

ASIA

E: asia-sales@ptgrey.com

DISTRIBUTORS

JAPAN—ViewPLUS Inc. (www.viewplus.co.jp)

KOREA—CYLOD Co., Ltd. (www.cyrod.com)

CHINA—LUSTER LightVision (www.lusterlighttech.com)

SINGAPORE, THAILAND, MALAYSIA—Voltrium Systems (www.voltrium.com.sg)

TAIWAN—Apo Star Co., Ltd. (www.apostar.com.tw)

UNITED KINGDOM AND IRELAND—ClearView Imaging (www.clearviewimaging.co.uk)