

OLYMPUS[®]

Your Vision, Our Future

Polarizing Microscope

BX51-P

BX2 Series

BERTRAND LENS

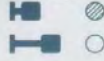

OLYMPUS
BX51

UPlanFL M
40x / 0.75 NA
∞ / 0.17 / FN205

0.8 0.6 0.4 0.2

9
8
6
4
P
PRE-SET

OLYMPUS

UIS2
World-leading optics

Unsurpassed optics render polarized light images sharper than ever before.

Olympus is proud to introduce the BX51-P, the new polarizing microscope with superb performance in polarized light. It's a breakthrough combination of world-renowned UIS2 infinity-corrected optics and Olympus original optical-design. Olympus has also devised a new, extended line of compensators to make the BX51-P versatile enough to handle observation and measuring applications in virtually any field.

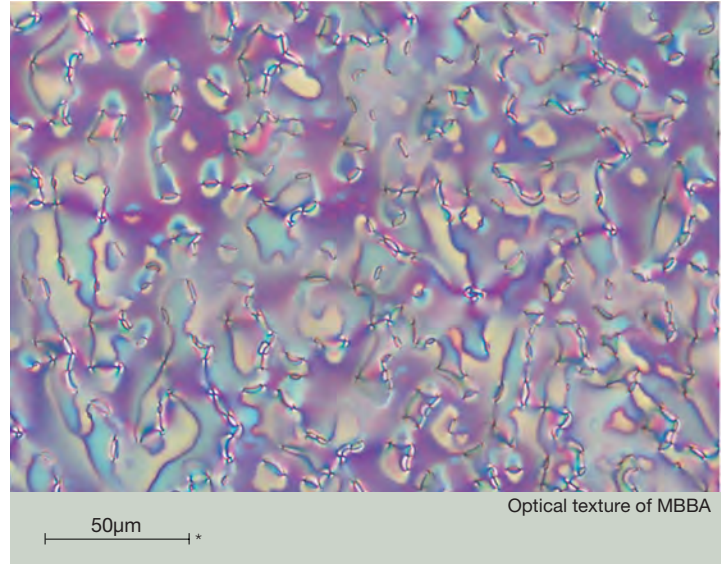
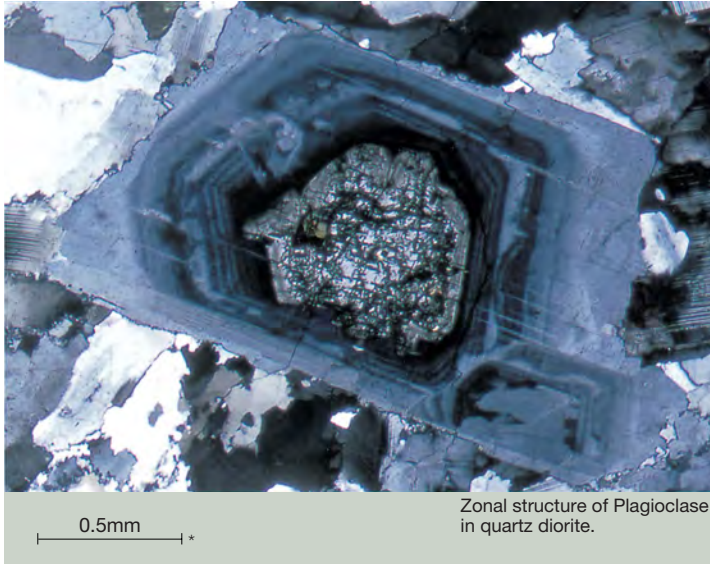

*Scales indicate actual size of samples

UIS2 provides outstanding system expandability.

By maximizing the advantages of infinity correction, the UIS2 optical system prevents the deterioration of optical microscope performance and eliminates magnification factors, even when polarizing elements like analyzers, tint plates or compensators are introduced into the light path. Maintaining the highest level of system flexibility, the BX51-P also accepts intermediate attachments available for the BX2 Series system microscopes, as well as cameras and digital imaging systems.



An upgrade in polarization characteristics.

Thanks to Olympus' sophisticated design and manufacturing technology, the ACHN-P and UPLFLN-P strain-free objectives reduce internal strain to an absolute minimum. Olympus has also totally redesigned its polarizers and polarizing condensers to further enhance performance in polarized light. This means a higher EF* value, resulting in unmatched image contrast. To meet a diversity of research and application requirements, the universal UPLFLN-P series objectives have been designed to accommodate a wide range of observation methods, including Nomarski DIC and fluorescence microscopy, in addition to polarized light observation.

*The EF (extinction factor) is the brightness ratio between parallel and crossed pol-filters. The higher the EF value, the better the extinction.



UPLFLN-P Series



ACHN-P Series

UPLFLN-P Series

Item	N.A.	W.D.
UPLFLN 4xP	0.13	17.0 mm
UPLFLN 10xP	0.3	10.0 mm
UPLFLN 20xP	0.5	2.1 mm
UPLFLN 40xP	0.75	0.51 mm
UPLFLN 100xOP	1.3	0.2 mm

PLN-P

Item	N.A.	W.D.
PLN 4xP	0.1	18.5 mm

ACHN-P Series

Item	N.A.	W.D.
ACHN 10xP	0.25	6.0 mm
ACHN 20xP	0.40	3.0 mm
ACHN 40xP	0.65	0.45 mm
ACHN 100xOP	1.25	0.13 mm

*All UIS2 objectives and WHN eyepieces: lead-free eco-glass

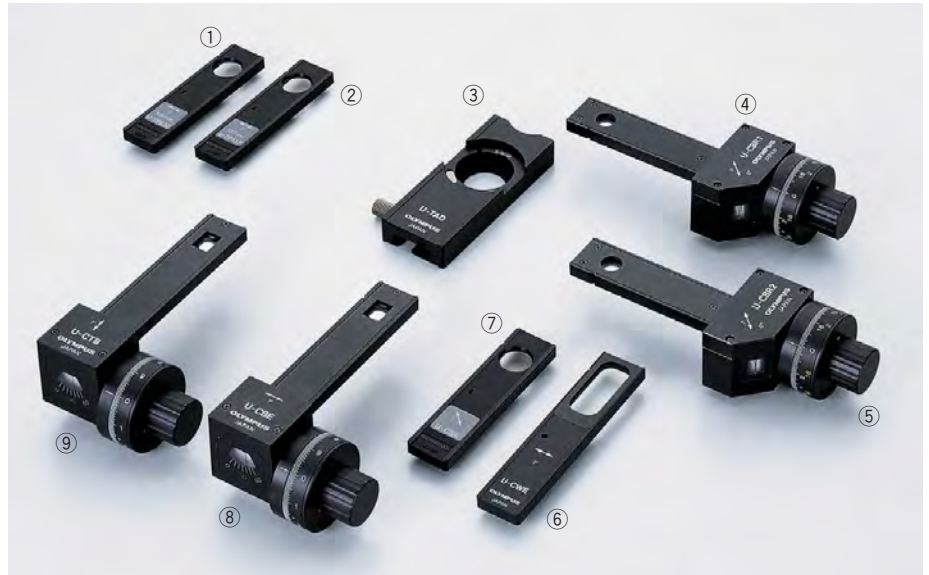

①U-TP530 ②U-TP137 ③U-TAD ④U-CBR1 ⑤U-CBR2 ⑥U-CWE2 ⑦U-CSE ⑧U-CBE ⑨U-CTB

An extensive range of compensators is available.

Six different compensators are available for the BX51-P microscope, allowing measurement of various retardation levels, ranging from 0 to 20λ . For easier

measurement, the direct readout method is featured. Higher image contrast can be attained by using a Senarmont* or Brace-Koehler compensator to change the retardation level in the entire field of view.

* Used with monochromatic green filter, IF546 or IF550.

Measuring range of compensators

Compensator	Measurement range	Applications
Thick Berek (U-CTB)	0-11,000 nm (20λ)	Measurement of high retardation level ($R^* > 3\lambda$), (crystals, macromolecules, fiber, etc.)
Berek (U-CBE)	0-1,640 nm (3λ)	Measurement of retardation level (crystals, macromolecules, living organisms, etc.)
Senarmont compensator (U-CSE)	0-546 nm (1λ)	Measurement of retardation level (crystals, living organisms, etc.) Enhancement of image contrast (living organisms, etc.)
Brace-Koehler compensator 1/10 λ (U-CBR1)	0-55 nm (1/10 λ)	Measurement of low retardation level (living organisms, etc.)
Brace-Koehler compensator 1/30 λ (U-CBE2)	0-20 nm (1/30 λ)	Enhancement of image contrast (living organisms, etc.)
Quartz wedge (U-CWE2)	500-2,200 nm (4 λ)	Approximate measurement of retardation level (crystal, macromolecules, etc.)

*R= retardation level

For more accurate measurement, it is recommended that compensators (except U-CWE2) be used together with the interference filter 45-IF546.



①U-CPA ②U-P4RE ③U-AN360P-2 ④U-OPA ⑤U-POC-2

Unmatched sharpness in orthoscopic and conoscopic observations.

With a U-CPA conoscopic observation attachment, changeover between orthoscopic and conoscopic observation is simple and quick.

Focusing of conoscopic images is easy and accurate. Employing a Bertrand field stop makes it possible to obtain consistently sharp and clear conoscopic images.



Enhanced operational ease and outstanding optical performance.

- With the U-CPA conoscopic observation attachment, the changeover between orthoscopic and conoscopic observation methods is simple and quick — just slide the Bertrand lens control knob in or out.
- The circular rotatable stage has two centering knobs and allows smooth sample rotation. A settable click stop every 45 degrees enables accurate observation and measurement.
- An ergonomic Y-shaped frame ensures comfortable, efficient observation with less fatigue, even over prolonged periods.
- Standard field number F.N. 22 represents a 21% increase in field size, covered with the conventional F.N. 20.
- The high intensity 12 V, 100 W halogen light source combined with the UIS2 optical system and its high transmittance result in exceptionally bright and sharp images.
- Mounting an attachable cross-movement mechanical stage (U-FMP) onto the circular rotatable stage makes for improved observation efficiency. Interference between the mechanical stage and the objectives is eliminated, so that images of superb quality can be effortlessly observed with all objective magnification.



U-FMP

BX51-P system diagram

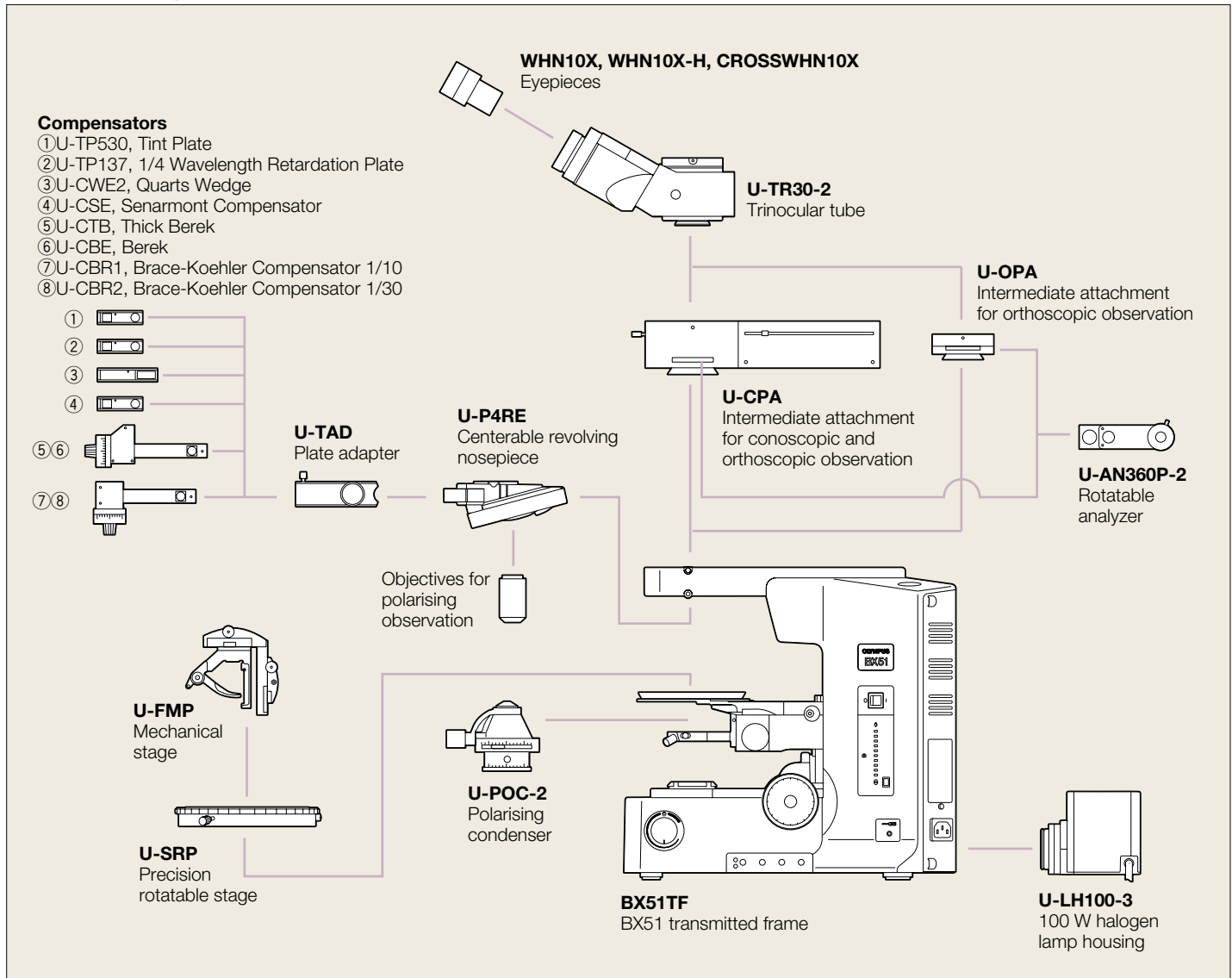

BX51-P dimensions

(unit: mm)

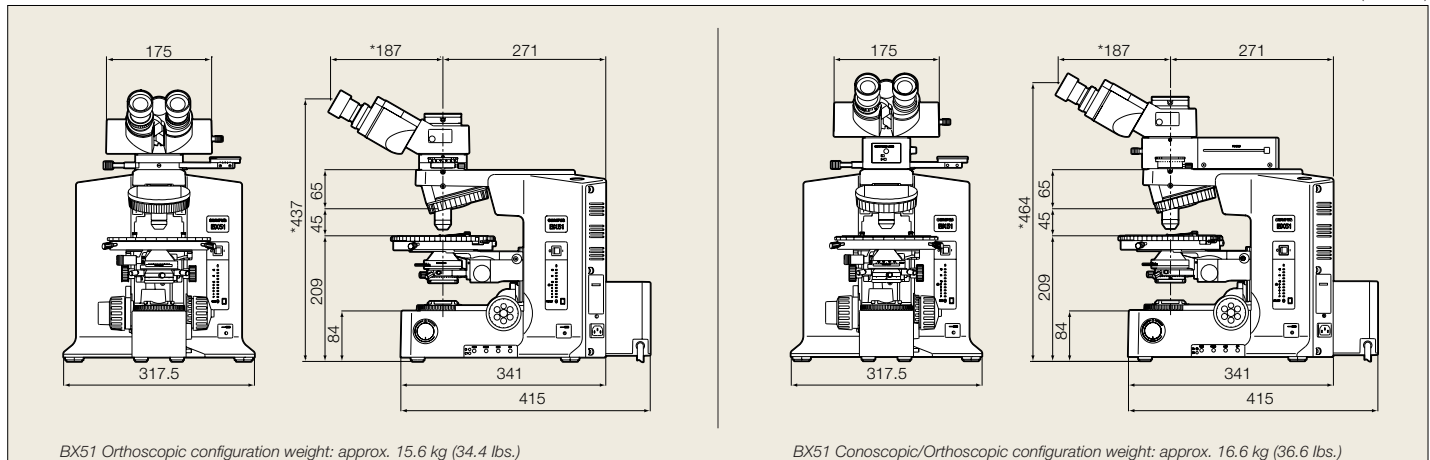

BX51-P specifications

Item	Conoscopic and orthoscopic observation (U-CPA)	Orthoscopic observation (U-OPA)
F.N.	22	22
Bertrand lens	Focusable	—
Bertrand field stop	ø3.4 mm diameter (fixed)	—
Polarized light intermediate attachment (U-CPA or U-OPA) Engage or disengage Bertrand lens changeover between orthoscopic and conoscopic observation	Position of slider ● in Position of slider ○ out	—
Analyzer slot	Rotatable analyzer with slot (U-AN360P-2)	
Analyzer (U-AN360P-2)	360° dial-rotatable Rotatable minimum angle 0.1°	
Revolving centerable nosepiece (U-P4RE)	Quadruple, centerable attachable components: 1/4 wavelength retardation plate (U-TAD), tint plate (U-TP530) and various compensators can be attached using plate adapter (U-TAD)	
Stage (U-SRP)	Polarizing rotatable stage with 3-point centering function. 360° rotatable, lockable in any position, 360° graduated in 1° increments (minimum retardation resolution 6', using vernier scale) 45° click stop function •Slide holder (U-SCB2) and mechanical stage (U-FMP) can be attached	
Condenser (U-POC-2)	Achromat strain-free condenser (U-POC-2), 360° rotatable polarizer with swing-out achromatic top-lens, Click stop at position "0°" is adjustable. N.A. 0.9 (top-lens in) N.A. 0.18 (top-lens out) Aperture iris diaphragm: adjustable from 2 mm to 21 mm diameters	

- OLYMPUS CORPORATION is ISO14001 certified.
- OLYMPUS CORPORATION is FM553994/ISO9001 certified.
- Illumination devices for microscope have suggested lifetimes. Periodic inspections are required. Please visit our web site for details.
- Specifications and appearances are subject to change without any notice or obligation on the part of the manufacturer.



OLYMPUS CORPORATION
 Shinjuku Monolith, 3-1, Nishi Shinjuku 2-chome, Shinjuku-ku, Tokyo, Japan
OLYMPUS EUROPA HOLDING GMBH
 Wendenstrasse 14-18, 20097 Hamburg, Germany
OLYMPUS AMERICA INC.
 3500 Corporate Parkway, Center Valley, Pennsylvania 18034-0610, U.S.A.

OLYMPUS AUSTRALIA PTY. LTD.
 31 Gilby Road, Mt. Waverley, VIC 3149, Melbourne, Australia.
OLYMPUS LATIN AMERICA, INC.
 5301 Blue Lagoon Drive, Suite 290 Miami, FL 33126, U.S.A.