

S 9432 HPLC PUMP SYSTEM

HIGH PRESSURE GRADIENT SYSTEM

USER MANUAL

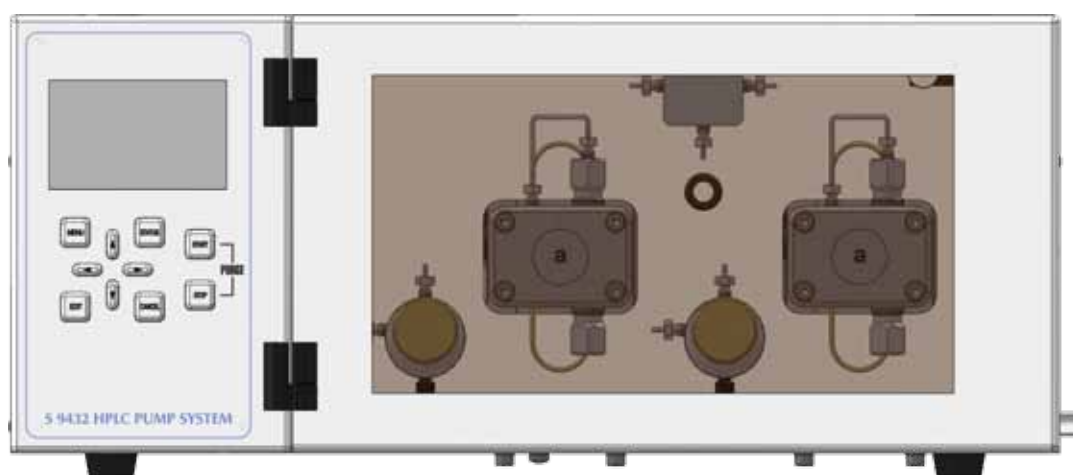

TABLE OF CONTENTS

Contents

1. Introduction	5		
1.1 How to Use this Manual	5		
1.1.1 Symbols	5		
1.2 Safety Information	6		
1.2.1 General Safety Information	6		
1.2.2 Intended Purpose	6		
1.2.3 Environmental Safety	6		
1.2.4 Electrical Safety	6		
2. Instrument Overview	9		
2.1 General Instrument Overview	9		
2.1.1 Pump Mechanic	9		
2.1.2 Gradient Module	11		
3. Instrument Description	13		
3.1 General Instrument Description	13		
3.1.1 Front Panel Description	13		
3.1.2 Back Panel Description	15		
3.2 Functional Description	16		
3.2.1 Front Elements	16		
3.2.2 Functional Elements	17		
4. Instrument Setup	19		
4.1 Unpacking	19		
4.2 Capillary Connections	20		
4.3 Backside Connections	21		
4.3.1 Drain/Gas Exhaust Connections	21		
4.3.2 Electrical Connections	22		
4.3.3 Remote Connector	23		
5. Instrument Menus	25		
5.1 Keyboard	25		
5.2 Status Screen	26		
5.3 Menu Description	27		
5.3.1 Submenu: Pump Menu ⇒ Pump Settings	28		
5.3.2 Submenu: Pump Menu ⇒ Run Parameters	29		
5.3.3 Submenu: Pump Menu ⇒ Calibration	30		
		5.3.4 Submenu: Gradient Menu	31
		5.3.5 Submenu: Degaser Settings	32
		5.3.6 Submenu: Systemmenu	33
		6. Instrument Operation	35
		6.1 Overview	35
		6.1.1 Internal Mode	35
		6.1.2 External Mode	35
		6.1.3 Serial Mode	35
		6.2 Priming the Pump	35
		6.3 Operating the Pump in Manual Mode	37
		6.3.1 Starting the Pump	37
		6.3.2 Stopping the Pump	37
		6.4.2 Stopping the Pump	38
		7. Instrument Maintenance	39
		7.1 Pumphead	39
		7.1.1 Pumphead Assembly	39
		7.1.2 Piston Backflushing	40
		7.1.3 Change of Piston Ring	40
		7.1.4 Replacing Check Valves	40
		Appendix A: Compressibility	43
		Appendix B: Specifications	45
		B.1 Technical Specifications	45
		B.1.1 Vacuum Chamber (optional)	45
		B.1.2 Vacuum Pump (optional)	45
		B.1.3 Pump	45
		B.2 Environmental Conditions	46
		B.2.1 Operational Conditions	46
		B.2.2 Storage Conditions	46
		Appendix C: Accessories	47
		C.1 Standard Accessories	47
		Isocratic Version	47
		Appendix D: Version Control	49
		D.1 Version History	49

1. INTRODUCTION

1.1 How to Use this Manual

This manual is designed as a reference to the installation, operation and maintenance of the *S 9432 HPLC Pump System*.

It is strongly recommended to review this manual before operating the instrument.

The content of this manual is subject to change without notice. This document is believed to be complete and accurate at the time of publication.

The Manufacturer is not liable for any damage resulted from the use of this manual.

1.1.1 Symbols

Throughout this manual important text sections are marked with the following symbols:

This section includes important information which may result in instrument or personal damage if not carefully followed.



This section includes important information for the proper operation of the instrument. Failure to follow this information may result in faulty behaviour of the instrument and/or wrong analysis results.



This section emphasizes some detailed information intended to optimize the performance of the instrument or to give a better understanding of some technical details.



1.2 Safety Information

This instrument is compliant with all related standards as stated in Appendix B.

1.2.1 General Safety Information

The operation of any analytical instrumentation requires the operator to be familiar with the potential hazards of using chemical solvents.

To avoid personal injury and/or damage to the instrument the operator is responsible to follow all safety information herein.

The manufacturer assumes no liability for any damage resulted from not following any of these safety procedures.

1.2.2 Intended Purpose

This instrument is designed and certified as a general purpose laboratory instrument for research and routine analysis work only. It is not certified for in-vitro or other medical applications.

Any use outside this intended purpose does not fall with the manufacturer's liability.

1.2.3 Environmental Safety

Only operate the instrument in well-ventilated areas. If volatile or flammable solvents are used with this instrument, arrange for proper disposal of any waste and/or fumes.

Always properly dispose any waste solvents.

Avoid open flames and sparks when working with flammable and volatile solvents.

In case of instrument leakage, turn off the instrument and remedy the leakage problem immediately.

1.2.4 Electrical Safety

Always use the provided power cords.

Replace faulty power cords and other cables before operating the instrument.

Always replace blown fuses with original spare fuses.

When the instrument's housing is open, electrical connections will be exposed. Disconnect the instrument from the main power before opening the housing.

**The housing should only be opened by certified service personnel!
Damage of the instrument or injury may result from improper handling.**



2. INSTRUMENT OVERVIEW

2.1 General Instrument Overview

The *S 9432 HPLC Pump System* is a very flexible and powerful HPLC solvent delivery system. The system is available as Isocratic HPLC pump and Quaternary Low-Pressure Gradient Pump with optional integrated online vacuum degasser.

The Quaternary Low-Pressure Gradient version incorporates an active low pressure mixer with adjustable mixing volume. The mixing chamber volume can be freely adjusted. An optional integrated vacuum degasser removes dissolved gases in the mobile phase and prevents air bubbles in the system.

2.1.1 Pump Mechanic

The *S 9432*'s pump mechanic is a robust design for long lifetime and minimal maintenance.

Stepper Motor

The stepper motor driven camshaft, driving the pistons is optimized for the typical analytical flow range, especially in the lower flow rate regions.

Permanent Lubrication

The camshaft and piston drive is permanently lubricated within a sealed chamber. The special lubrication used makes the *S 9432* suitable for 24/7 operation.

Active Piston Backflushing (optional)

The optional piston backflushing actively flushed the piston after the primary seals to prevent crystallization of buffer solutions. The piston back-

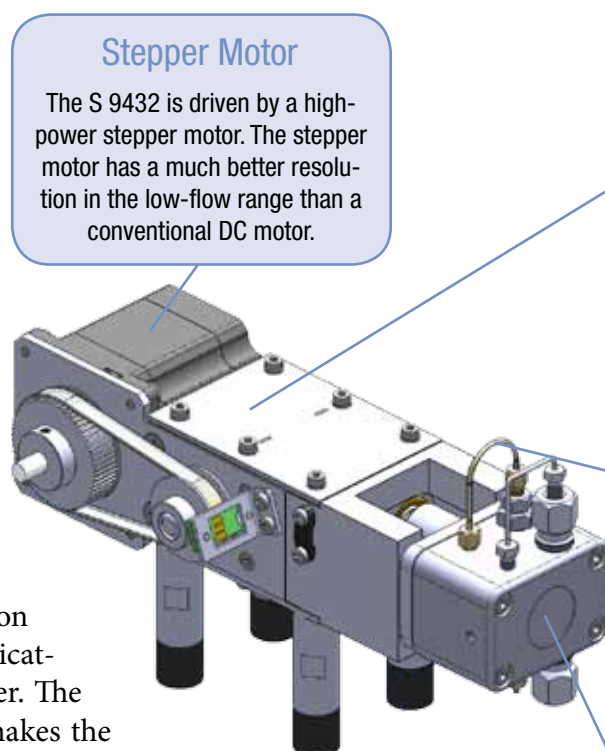

Stepper Motor

The *S 9432* is driven by a high-power stepper motor. The stepper motor has a much better resolution in the low-flow range than a conventional DC motor.

Lubrication

The *S 9432* camshaft is constantly lubricated within a sealed chamber to guarantee long lifetime and low maintenance.

Optional: Active Piston Backflushing

The *S 9432*'s pump head incorporates an automatic piston backflushing system; this system is interchangeable with old pumps and does not require an additional motor.

Dual-Piston Pumphead

The *S 9432* pumps use a dual-piston pumphead for low pulsation. Together with electronic pressure compensation the *S 9432* pumps are suitable for all analytical tasks in HPLC and GPC.

flushing is incorporated into the pumphead and does not require any additional pump or motor. Because of this, all pumps are upgradable to active piston backflushing at any time without downtime.

Pumphead

The short-stroke dual-piston pumphead is optimized for low pulsation and accurate delivery. The *S 9432 HPLC Pump System* can be fitted with any of the following pumpheads:

- Analytical Pumphead (max. Flow Rate 10.000 ml/min)
- Micro Pumphead (max. Flow Rate: 4.000 ml/min)
- Semi-Preparative Pumphead (max. Flow Rate: 40.000 ml/min)

In addition to the performance types above, all pumpheads can be delivered in:

- Stainless Steel
- PEEK
- (Titanium on request)



The different pumpheads should not be exchanged freely on a specific pump, as the flow rate is adjusted to a specific type of pumphead. When the pumphead is changed without proper flow adjustment, the flow rate will not be accurate!

2.1.2 Gradient Module

The *S 9432 HPLC Pump System* has the optional includes a Gradient Module. The whole module is mounted inside the pump and consists of several elements.

Active Gradient Mixer (Optional)

The active mixer has a variable volume mixing chamber, with a magnetic stirrer unit built-in. The mixing volume can be adjusted freely to optimise mixing performance for different kind of solvents and applications.

Vacuum Pump (Optional)

The optional online vacuum degasser consists of a Vacuum Pump and four Vacuum Chambers. The Vacuum Pump is a high-efficiency membrane pump using an advanced Teflon membrane for highest possible chemical compatibility and long lifetime. The specific Teflon membrane is developed for high frequency deformations to achieve an excellent lifetime of the membrane as chances of ruptures are much reduced.

Vacuum Chambers (Optional)

The four Vacuum Chambers used in the Quaternary Gradient Module are low-volume, high efficiency chambers using the advanced Teflon AF[®] material. The inner diameter and wall strength of the Teflon AF[®] capillary used in these chambers is optimized for best efficiency with low volume. Teflon AF[®] is as chemical compatible as normal Teflon, but has a much higher gas diffusion rate, making a capillary 1000 times more efficient.

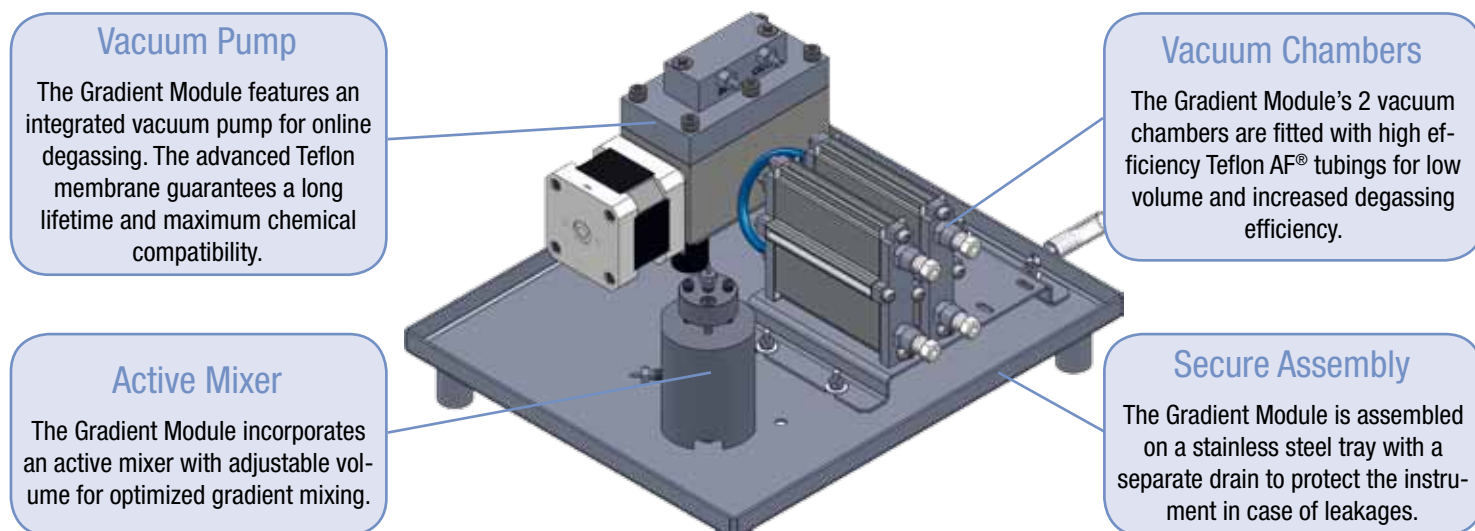

Vacuum Degasser Working Principle

The solvent flows through a short length of Teflon AF® capillary inside a sealed chamber. This chamber (vacuum chamber) is completely sealed to the environment and vacuum is applied with a pump.

This vacuum pump decreases the pressure inside the chamber to near-vacuum. Due to this vacuum any dissolved gases in the solvent running through the inner capillary are removed through its semi-permeable membrane wall. The high efficiency of the Teflon AF® material allows the usage of a very short length of capillary inside the vacuum chamber. This low dead volume offers a quick solvent exchange and very short equilibration time.

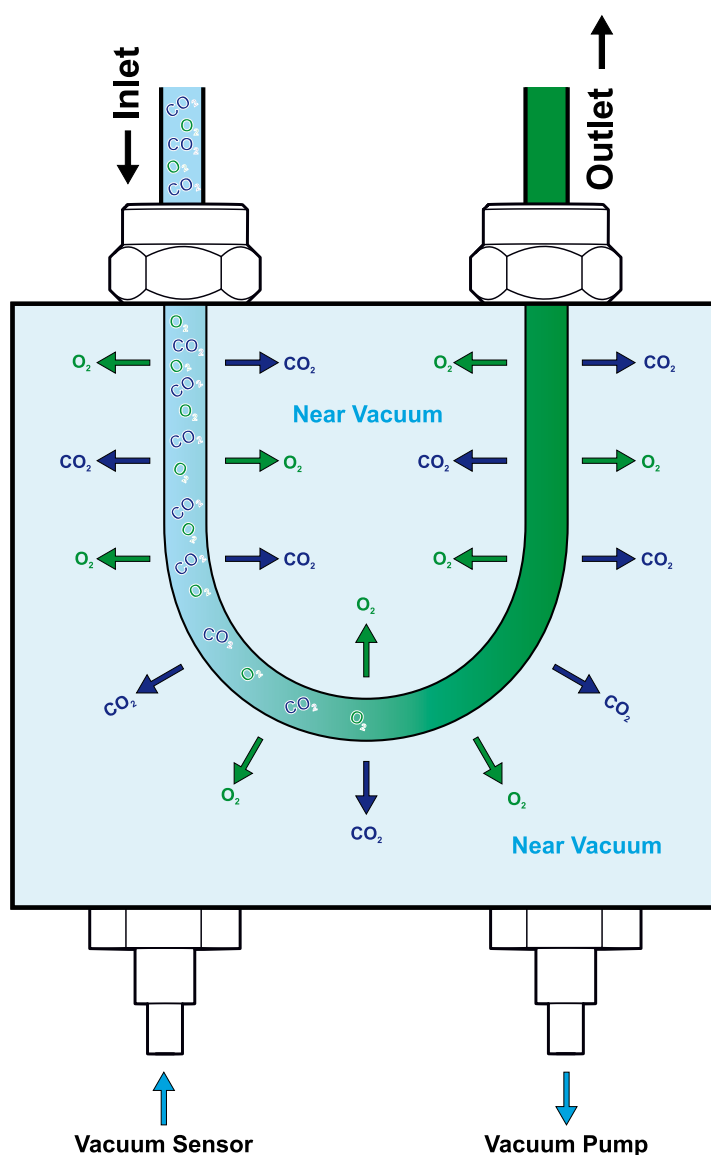

3. INSTRUMENT DESCRIPTION

3.1 General Instrument Description

3.1.1 Front Panel Description

The front panel of the *S 9432 HPLC Pump System* consists of three main elements: the TFT Display (1), the Keyboard (2) and the Front Cover (3).

The 3" TFT Display shows the current status information and is used with the Keyboard to adjust instrument settings and fully operate the instrument in stand-alone mode without a PC required.

The Front Cover has a view panel, so that the important parts (Pumphead and Purge Valve) are always visible to the operator. In case of a leak it can be detected before solvents are leaking out of the bottom of the Front Cover.

The Front Cover can be opened to easily access the Pumphead, Purge Valve and capillary connections.

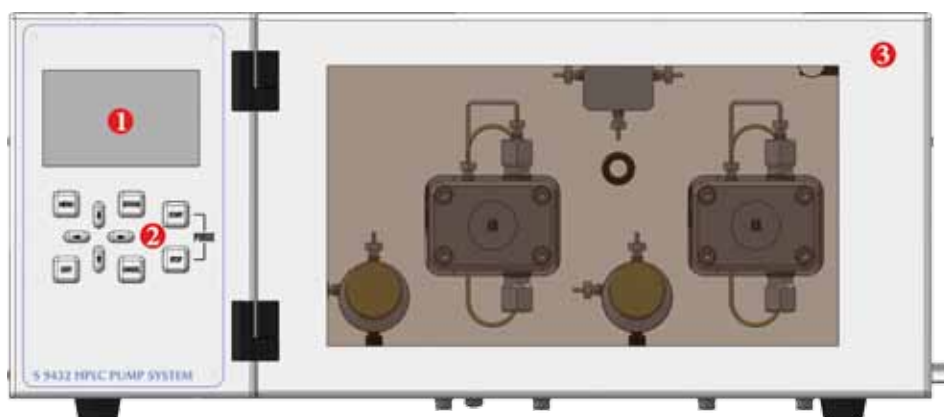

#	Element
1	TFT Display
2	Keyboard
3	Front Cover

Removing the Front Cover

The Front Cover of the *S 9432 HPLC Pump System* is completely removable at its hinges.

- Open The Front Cover to 90° (in order to get free of any instrument stacked on top)

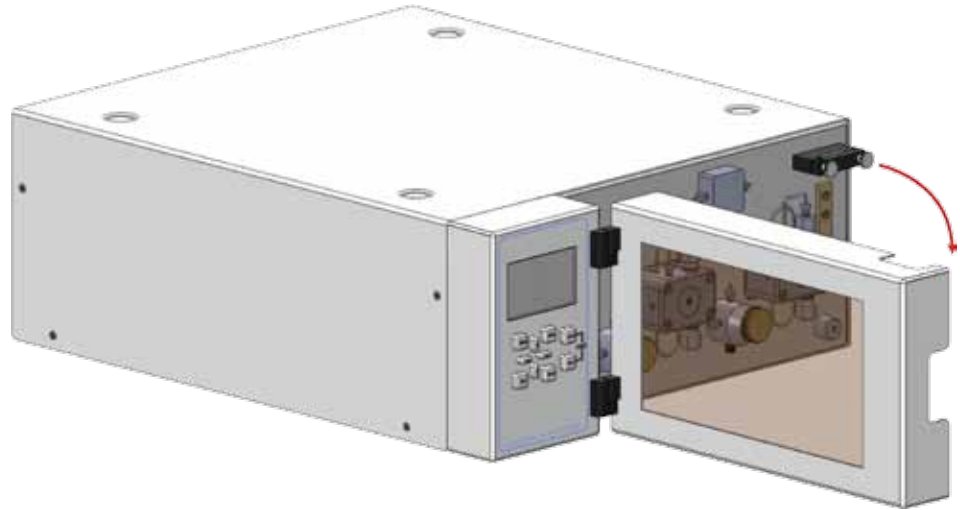

- Remove the Front Cover
- Store the Front Cover at a safe place

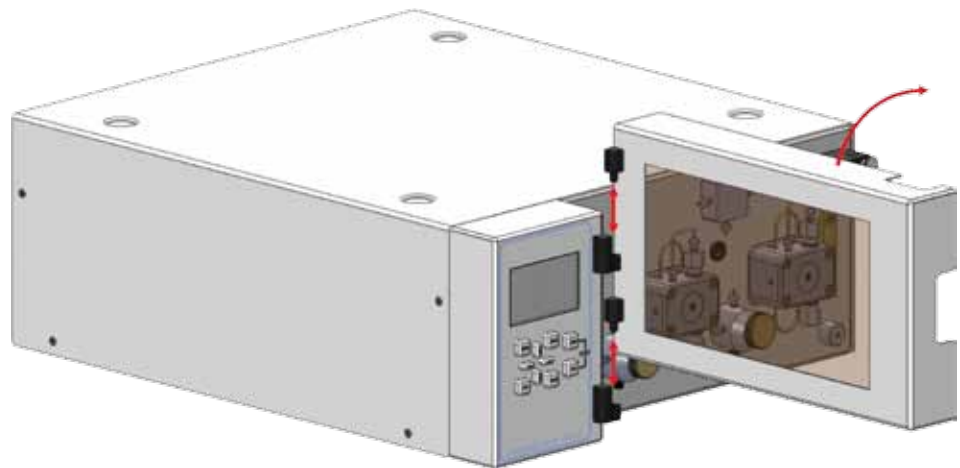

3.1.2 Back Panel Description

The back panel of the *S 9432 HPLC Pump System* houses the power and interface connectors and several drain outlets.

The Power Cord Connection & Power Switch housing holds the main fuse in an internal fuse carrier.

The optional Drain Outlet is the leakage drain for the Gradient Mixer Module.

The optional Gas Outlet is the gas outlet of the Vacuum Pump where all solvent fumes from the degassing process are exhausted.

The digital I/O and other interface connectors are used for remote instrument control and are discussed in a later chapter.



#	Element
1	Gradient Mixer Module Drain (optional)
2	Vacuum Degasser Gas Outlet (optional)
3	Instrument Serial Number
4	Power Cord Connection & Power Switch
5	Remote Digital I/O Connector
6	RS-232 Interface Connector
7	RS-485 Interface Connectors
8	USB Interface Connector

3.2 Functional Description

3.2.1 Front Elements

The *S 9432 HPLC Pump System* has all important parts directly accessible from the front panel when the Front Cover is opened or removed.

The Capillary Holder (3) holds the pump inlet capillary in place.

The Solvent Inlets Block (4) has an inlet connection for each of the 2 solvents (A and B). Below is the Solvent Outlet Block for connecting the solvents A and B to the pump head inlets.

The Pumpheads (7 & 9) is completely accessible from the front to make capillary connections or change pump sealings.

The Purge Valves (8 & 10) is used for the priming of the pumps.

#	Element
1	TFT Display
2	Keyboard
3	Capillary Holder
4	Solvent Inlets Block
5	Solvent Outlet Block
6	Pump Outlet
7	Pumphead B
8	Purge Valve B
9	Pumphead A
10	Purge Valve A

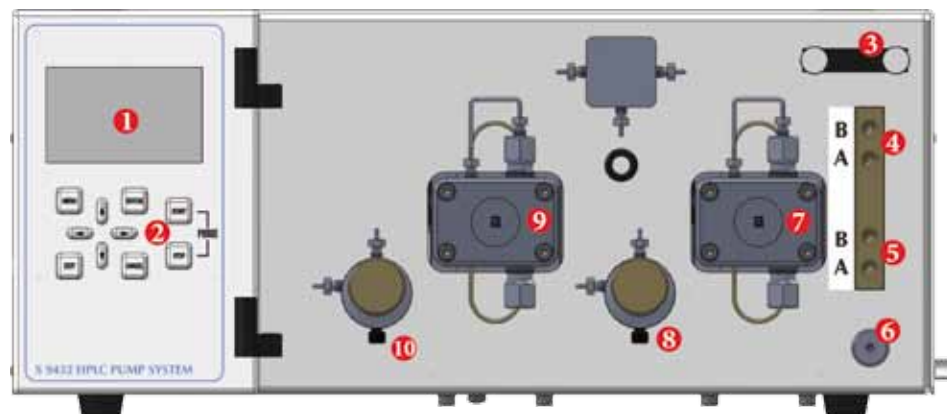

3.2.2 Functional Elements

All functional elements of the *S 9432 HPLC Pump System* are located inside the instrument.

The Display PCB (1) controls the TFT Display and Keyboard. It is accessible when the display panel is removed.

The Controlled PCB (2) controls the whole pump.

The Power Supply Unit (3) supplies 24V to the PCB's and pump motor. The input voltage is variable from 90 V to 240 V.

The Vacuum Pump (4) is mounted on a drain tray. It is connected to the Vacuum Chambers (5) and the gas outlet on the back panel.

The Vacuum Chambers (5) are mounted on a drain tray and are connected to the vacuum pump and the Controller PCB.

The Mixing Chamber (6) is mounted on a drain tray and connected to Solvent Inlet Block on the front panel and the Vacuum Chambers (5).

The Pump Mechanic (7) drives the pumphead and includes the camshaft, lubrication chamber, driving pistons and the stepper motor.

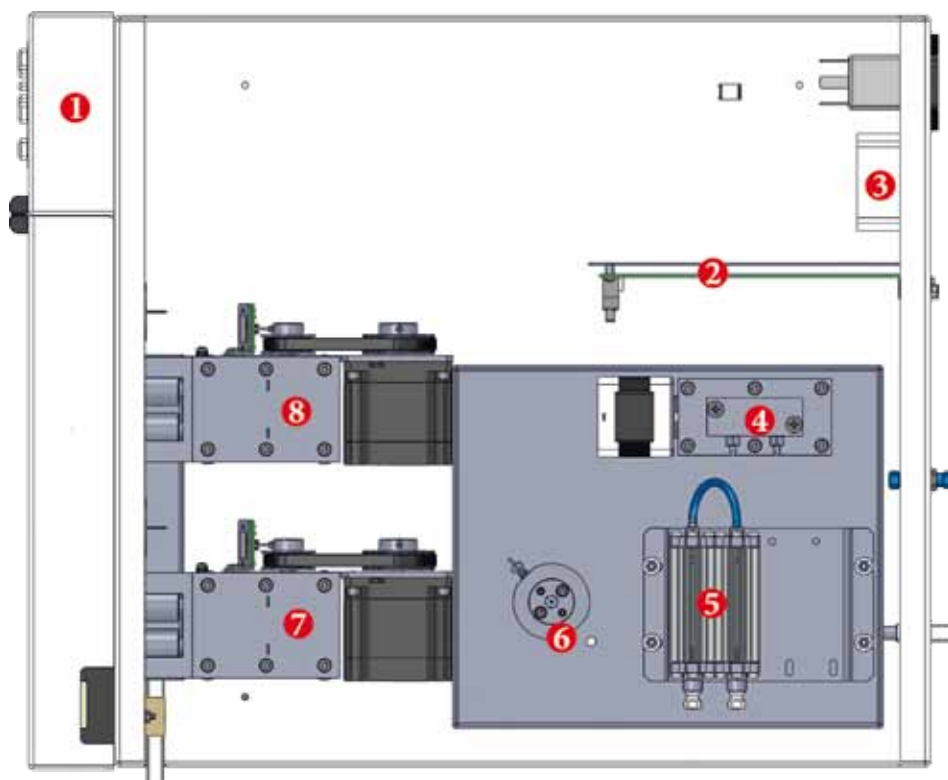

#	Element
1	Display PCB
2	Controller PCB
3	Power Supply Unit
4	Vacuum Pump
5	Vacuum Chambers (2)
6	Mixing Chamber
7	Pump Mechanic B
8	Pump Mechanic A

4. INSTRUMENT SETUP

4.1 Unpacking

Remove the *S 9432 HPLC Pump System* from its package and put it on the working desk. Check the instrument thoroughly for any damage that may have occurred during shipping. Contact your supplier in case of any damages.

Check the accessories shipped with the instrument if everything is complete and in good condition.

4.2 Capillary Connections

The next step is to make all fluid connections. The following list describes all necessary steps to make the proper capillary connections:

With Degasser Option:

- Connect the 1/8" PVDF tubing to the Solvent Inlets (2)
- Connect the 1/8" PVDF tubing from the Solvent Outlets (3) to the Pumphead Inlets (5 and 6)
- Fix the 1/8" capillaries with the Capillary Holder (1)

Without Degasser Option:

- Connect the 1/8" PVDF tubing to the Pumphead Inlets (5 and 6)
- Fix the 1/8" capillaries with the Capillary Holder (1)
- Connect a 1/16" capillary (Micro/Analytical = I.D. 0.5mm; Semi-Preparative = I.D. 0.75mm) to the Pump Outlet (4); this capillary is connected to the autosampler or manual injection valve

#	Element
1	Capillary Holder
2	Solvent Inlets
3	Solvent Outlets
4	Pump Outlet
5	Pump B Inlet
6	Pump A Inlet

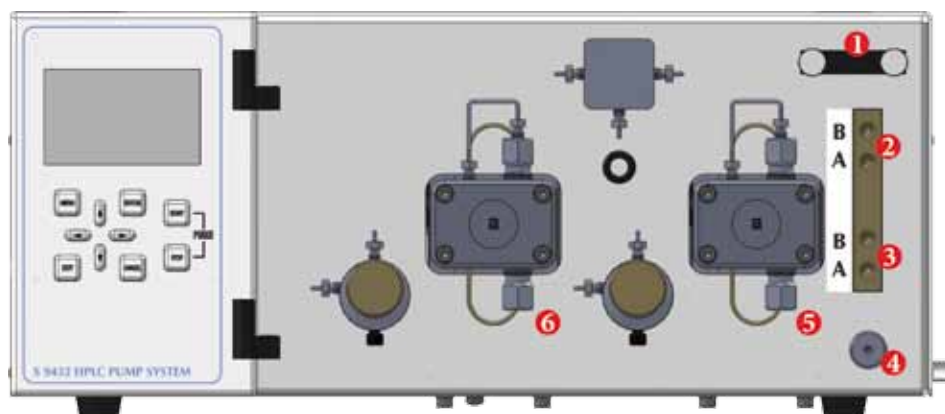

WARNING

Make sure that the eluent bottles are on a higher level than the S 9432, so that the solvents can freely flow downwards!

4.3 Backside Connections

4.3.1 Drain/Gas Exhaust Connections

The Drain Outlet is only connected with the optional Vacuum Degasser.

- Connect the supplied gas tubing (*blue colored*) to the GAS OUT connector on the backside of the instrument.
- Connect the supplied silica tubing to the DRAIN outlet on the back-

When working with aggressive and/or toxic solvents, make sure that any fumes from the GAS OUT connector is properly disposed of and not evaporated into the working area!



side of the instrument. In case of a leakage of the Gradient Mixer or Vacuum Degasser, solvent will be leaking through this tubing. Make sure that the liquids are collected in some vessel and properly disposed of.



#	Element
1	Drain
2	Gas Outlet

4.3.2 Electrical Connections

The Drain and Gas Outlets are only connected when the Vacuum Degasser Option is available.

- Connect the supplied power cord to the Mains connector (5).
- Connect the supplied RS-232 cable to the RS-232 connector (2) if the instrument is to be operated by PC
- Connect the remote control wires to the Digital I/O connector (1) if the instrument is to be run in External mode.

Please refer to **5. Instrument Operation** for further information about PC control and Remote control.

#	Element
1	Remote Digital I/O
2	RS-232 Serial Communication
3	RS-485 Communication Bus
4	USB Communication (not in use)
5	Mains Power Supply

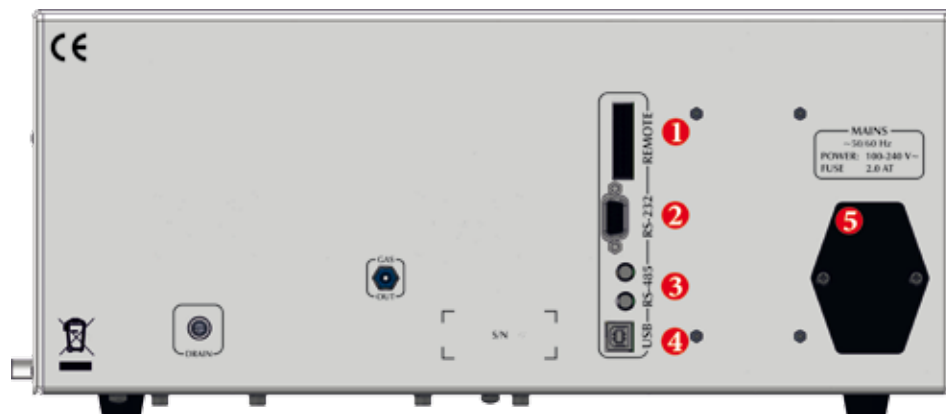

4.3.3 Remote Connector

Run Input

Used to start the pump with the current settings. EXTERN contact (see below) must be closed to activate this feature.

Extern Input

The EXTERN input contact must be closed for external operation.

Inject Input

Connection for a manual injection valve. The pump transfer the injection signal to the data system via RS-232.

Error Output

In case of a pump error, this output is set.

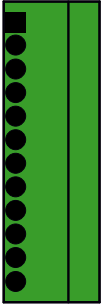
REMOTE	Pin	Function
	1	Run Input
	2	GND
	3	Extern Input
	4	GND
	5	Inject Input
	6	GND
	7	Error Output
	8	GND
	9	N.C.
	10	GND
	11	N.C.
	12	GND

5. INSTRUMENT MENUS

5.1 Keyboard

The *S 9432 HPLC Pump System* parameters can be adjusted at any time via the screen menu and keyboard on the front panel.

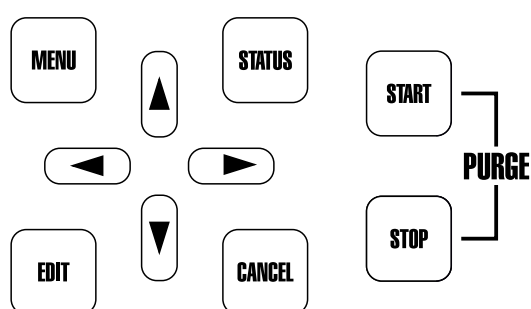

[MENU] Key

With the [MENU] key you can access the Main Menu and select a sub-menu.

[STATUS] Key

With the [STATUS] key you can access the status screen from any menu.

[EDIT] Key

Use the [EDIT] key to change any parameters. When you press the [EDIT] key, the selected parameter can be changed. Confirm the new setting by pressing the [EDIT] key again.

[CANCEL] Key

With the [CANCEL] key you can abort the change of a parameter. When pressing [CANCEL] key instead of [EDIT] key when changing a parameter, the change is discarded and the original value is used.

[CURSOR] Keys

The 4 arrow [CURSOR] keys are used to navigate the menus.

[START] Key

The [START] key starts the pump.

[STOP] Key

The [STOP] key stops the pump.

[PURGE] Key

The [PURGE] key ([START] and [STOP] together) is used to purge the pump.



Make sure that you open the Purge Valve before pressing the [PURGE] key. When activated, the Purge will run the pump with maximum flow rate and can damage the column if the Purge Valve is closed!

5.2 Status Screen

The Status Screen shows the most important parameters.

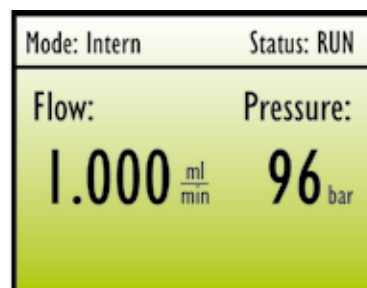
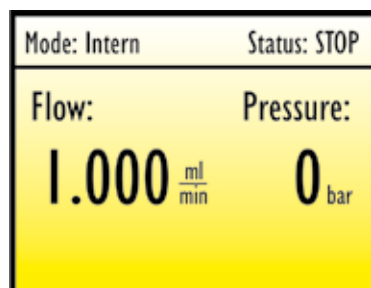

Mode

The top line shows the currently selected mode: *Intern*, *Extern* or *Serial*.

Status

On the top right the current status is displayed: *Stop*, *Hold*, *Run*, or *Error*

Flow

The Flow Rate is shown on the left center area. It always shows the current Flow Rate.

Pressure

The current pressure is shown in the right center area. The pressure is

shown in the selected unit (e.g. Bar, MPa, or PSI).

5.3 Menu Description

With the [MENU] key, the Main Menu is displayed.

Use the [CURSOR] key ([UP] and [DOWN]) to browse through the Main Menu for access of one of the Submenus.

Pump Menu
Enter Gradient Prog.
Degaser Settings
Systemmenu

Pump Menu	Pump Settings
	Run Parameters
	Calibration

Enter Gradient Prog.	Prog. Run
	Prog. Edit
	Enter Gradient

Degaser Settings	Degaser
	Mode
	Speed
	Vacuum Level

Systemmenu	Int./Ext./Ser.
	Software Display
	Software Mainb.
	24V Voltage
	Runtime

5.3.1 Submenu: Pump Menu ⇨ Pump Settings

Pump Settings	Min. Pressure
	Max. Pressure
	Max. Pr. Purge
	Change Unit
	Compressibility

Min.Pressure

The Minimum Pressure threshold. The pump will stop, if the pressure falls below this threshold.

Max.Pressure

The Maximum Pressure threshold. The pump will stop immediately, if the pressure rises above this threshold.

Max. Pr. Purge

The Maximum Purge Pressure threshold. The pump will stop immediately, if the pressure rises above this threshold when the Purge function is used. This a safety feature to prevent column damage when the purge valve is closed while Purge is active.

Change Unit

The Pressure Unit can be changed here. Available selections are: Bar, MPA, and PSI. All pressure values are shown in this selected pressure units.

Compressibility

The Compressibility can be changed here. A Compressibility of 1.000 is used for water and 0.700 for Methanol.

5.3.2 Submenu: Pump Menu ⇒ Run Parameters

Run Parameters	Hold Timeout
	Delay Time
	Start Ramp
	Stop Ramp

Hold Timeout

The Hold Timeout specifies a timeout after which the pump automatically stops when it is currently in Hold. If the Timeout is set to 0, this feature is disabled.

Delay Time

The Delay Time specifies a delay between starting the pump and the pump actually starting.

Start Ramp

The Start Ramp defines a time in which the flow slowly ramps up when started.

Stop Ramp

The Stop Ramp defines a time in which the flow slowly ramps down when stopped.

5.3.3 Submenu: Pump Menu ⇨ Calibration

Calibration	Network Address
	Head
	Head Constant
	Pressure Comp.
	Pressure Zero

Network Address

The Network address can be any number between 0 and 15. It is used for specific cases of external control mode.

Head

The Head settings defines the installed pump head.

Head Constant

The Head Constant is a setting for an individual pump's flow rate adjustment. Do not change this value.

Pressure Comp.

The Pressure Compensation is a setting for an individual pump's pressure compensation adjustment. Do not change this value.

Pressure Zero

The Pressure Zero is an offset for the installed pressure sensor. Only change this value when the pressure sensor is changed.

5.3.4 Submenu: Gradient Menu

Enter Gradient Prog.	Prog. Run
	Prog. Edit
	Enter Gradient

Prog. Run

Select the Program Number (1-8) which should be run.

Prog. Edit

Select the Program Number (1-8) to edit (see below).

Enter Gradient

In this menu the Gradient Program can be edited. The Program Number is selected in the Menu above.

#	Flow	Time	A	B
0	1.000	000.0	100	0
1	1.000	010.0	20	80

Editing Values

Each value of a Gradient Program line can be edited with the [EDIT] key and the [UP] and [DOWN] keys. Confirm the change with [EDIT] and cancel the change with [CANCEL] key.

Adding Lines

A new line can be added by pressing the [EDIT] key when the cursor is in the first (“#”) column.

Deleting Lines

A line can be deleted by pressing the [CANCEL] key when the cursor is in the first (“#”) column.

5.3.5 Submenu: Degaser Settings

Degaser Settings	Degaser
	Mode
	Speed
	Vacuum Level

Degaser

Select <ON> or <OFF> to switch the degaser on or off.

Mode

Select the degasser mode: HYSTERESIS mode switches the degasser on and off depending on the vacuum level. In CONTINUOUS mode the vacuum pump runs constantly.

Speed

The speed of the vacuum can be selected to be either HIGH or LOW. This speed setting has no impact on the degassing performance, just on the time needed to reach the vacuum level.

Vacuum Level

The current vacuum level is displayed (950 - vacuum chamber pressure).

5.3.6 Submenu: Systemmenu

Systemmenu	Int./Ext./Ser.
	Software Display
	Software Mainb.
	24V Voltage
	Runtime

Int./Ext./Ser.

The Operation Mode can be changed here between Intern, Extern or Serial.

Software Display

The Software Display is the installed firmware version of the Display PCB.

Software Mainb.

The Software Display is the installed firmware version of the Controller PCB.

24V Voltage

The 24V Voltage is an actual voltage reading for one of the PCB's controlled voltages.

Runtime

The runtime shows the total runtime of the pump.

6. INSTRUMENT OPERATION

6.1 Overview

The *S 9432 HPLC Pump System* can be operated in 3 different Operation Modes: Internal, External, or Serial

6.1.1 Internal Mode

In *Internal Mode* the instrument is controlled manually with the Keyboard.

6.1.2 External Mode

In *External Mode* the instrument is controlled via the Remote Digital I/O contacts.

6.1.3 Serial Mode

In *Serial Mode* the instrument is controlled by a PC software (e.g. *Clarity*) via RS-232 serial line.

6.2 Priming the Pump

Before the *S 9432 HPLC Pump System* can be operated it must be primed with the required mobile phase.

- connect the plastic syringe to the purge valve outlet
- suck the eluent through the tubing till it starts filling the syringe.
- keep the syringe on the purge valve outlet
- press [PURGE] and check if the syringe is filling with constant speed

Now, the pump is primed and ready for operation.

6.3 Operating the Pump in Manual Mode

Mode: Intern	Status: STOP
Flow: 1.000 $\frac{\text{ml}}{\text{min}}$	Pressure: 0 bar
A:100	B:0

6.3.1 Starting the Pump

The *S 9432 HPLC Pump System* can be started by pressing the [START] key. The pump will run at the selected flow rate.

Flow Start Ramp

If a time is set for the Start Ramp, the flow rate will slowly increase from 0 to the selected flow rate over a selected time (e.g. Start Ramp time). This feature gently increases flow and therefore pressure and may increase the lifetime of some specific columns.

Mode: Intern	Status: HOLD
Flow: 1.000 $\frac{\text{ml}}{\text{min}}$	Pressure: 32 bar
A:100	B:0

Mode: Intern	Status: Run Prog
Flow: 1.000 $\frac{\text{ml}}{\text{min}}$	Pressure: 32 bar
A:88.2	B:11.8

After the pump reached its flow rate, it automatically goes to HOLD; this means the pump is running, but the gradient program time is on hold.

The pump will switch from HOLD to RUN after pressing the [START] key again, or by external signal.

The current state of the gradient program can be checked on the Status Screen by pressing the [STATUS] key:

Mode: Intern	Status: Run Prog
Flow:	Pressure:
1.000 $\frac{\text{ml}}{\text{min}}$	32 bar
A:88.2	B:11.8

Mode: Intern	Status: Run Prog
Flow: 1.000 $\frac{\text{ml}}{\text{min}}$	Pres.: 32bar
Prog: 1	Time: 0.7/10.0
Stp: 1/4	Time: 0.7/6.0
88.2	B:11.8

The bottom line shows the current gradient composition while the center of the status screen shows the current step, step time and total time.

6.4.2 Stopping the Pump

The *S 9432 HPLC Pump System* can be stopped by pressing the [STOP] key. The pump will stop immediately, unless a Stop Ramp is set.

Flow Stop Ramp

If a time is set for the Stop Ramp, the flow rate will slowly decrease from the selected flow rate to 0 over a selected time (e.g. Stop Ramp time).

Maximum Pressure

In case the Maximum Pressure threshold is met, the pump stops immediately.

Minimum Pressure

In case the Minimum Pressure threshold is met, the pump stops if the pressure stays below the threshold for 30 seconds.

7. INSTRUMENT MAINTENANCE

7.1 Pumphead

7.1.1 Pumphead Assembly

The following diagram shows all the components of the dismantled pump head:

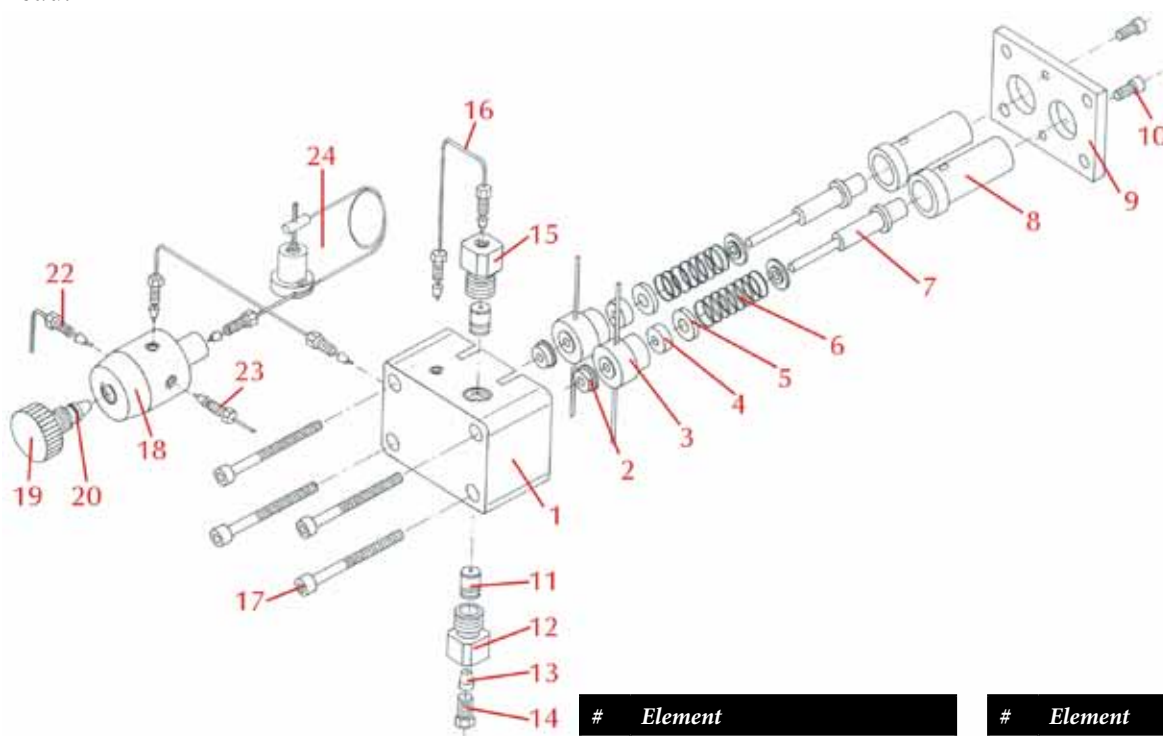

#	Element
1	Pump head body
2	Piston sealing ring
3	Piston guide with piston back flushing
4	Secondary sealing ring
5	Pressure spring
6	Ceramic piston assembly
7	Guide bearing
8	Centering disk
9	Mounting plate
10	Hollow screw
11	Check valve cartridge
12	Inlet valve housing (suction side)
13	Ferrule 1/8"

#	Element
14	Thrust bolt
15	Outlet valve housing (pressure side)
16	Capillary tube for connecting the damping piston
17	Hollow screws M4x45
18	Relief valve block
19	Venting screw
20	Sealing ring: relief valve
21	Capillary for connecting relief valve and pump head
22	Drain capillary from relief valve block
23	Solvent outlet
24	Pressure sensor

7.1.2 Piston Backflushing

When using saliferous eluents, a growth of salt crystals is possible behind the piston ring on the ceramic piston. Under unfavorable working conditions, these salt crystals can lead to a higher wearing of the piston ring.

Generally, it is sufficient to rinse the rinsing chamber (between piston ring and secondary sealing ring) with distilled water once a week. The water remaining in the rinsing chamber stops the crystallization of salt crystals. Therefore, the lower capillary tubes should be connected together with PTFE tubing so that the water remains in the rinsing chamber.

The rinsing of the chamber should be done with the plastic syringe delivered with the instrument.

7.1.3 Change of Piston Ring

- Loosen the two hollow screws (10) for removing the mounting plate (9)
- take off the guide bearing, piston assembly, pressure springs and centering discs
- pull out the piston guide
- pull out the piston rings very carefully with the help of a pair of tweezers
- completely insert the new sealing rings into the opening (flange upward); the small spring has to show in direction of the pump head
- insert the piston guide upward with the secondary sealing ring (white)
- put the ceramic piston into the guide bearing, insert the spring with the centering discs in the piston and place the whole unit on the piston guide
- put the mounting plate on top and fasten it with the hollow screws (10)
- completely push down both pistons by hand for several times in order to check if the pistons were jammed during the process of assembling

7.1.4 Replacing Check Valves

The check valves are constructed as cylindrical cartridges.

The cartridges have sealing rings, made of PEEK mounted on both sides.

These sealing rings have to ensure that the solvent will not bypass the check valve. Both valves, on the high and low pressure side of the pump are identical and therefore can be used for both sides.

Place the cartridge in the valve housing and fasten first by hand and then turn another half of a turn by using the 13mm wrench delivered with the instrument. If the pump is not delivering the correct flow rate, the valve housing might not be tightened enough. Before tighter fastening make sure, that the pump was carefully flushed.

Cleaning the Check Valve Cartridge

Generally, the check valves cartridges don't wear. However, a deposit of dirt in the valve can influence the function. In this case, only a limited improvement will be achieved when cleaning the fully assembled cartridge. The more dependable method is to dismantle the valve for cleaning.

In order to avoid any loss of valve parts, it is recommended to use a small container for the process is dismantling.



- pull out both sealing discs (1)
- carefully push out the valve contents (3-5)
- clean the valve part depending on the degree of dirt either with a washing bottle or with an ultrasonic bath
- insert the sealing disc which is next to the ring marker
- then insert the sapphire seat with the polished side toward the ruby ball
- place the ruby ball in the deeper side of the check guide (5) and put both into the bearing (2) with the ruby ball (4) facing the sapphire seat (3)
- press the second sealing disc on top

After assembling, check the functioning of the valve by blowing air through it. It is possible to blow the air from this side of the ring marker through the valve and it should lock when blowing the other direction.

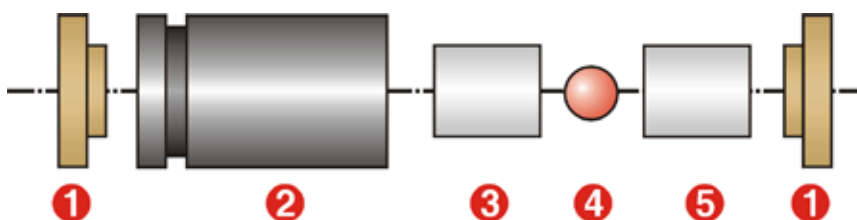

#	Element
1	PEEK sealing ring
2	Valve bearing with ring marker
3	Sapphire seat
4	Ruby ball
5	Check guide made of ceramic

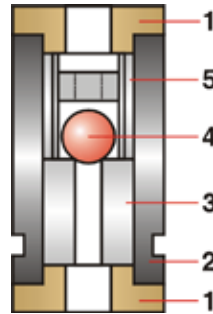

APPENDIX A: COMPRESSIBILITY

A general problem for constant flow delivery with piston pumps is the compressibility of the solvents under pressure.

Any liquid shows a specific volume elasticity. If the liquid is influenced by pressure changes Δp , the volume will change by ΔV . The volume V will become the same as before, if the pressure will be reduced to the original value again. The dimension of the change in volume is the compressibility.

This can be shown as:

$$\text{Compressibility} = \frac{\text{relative change of the volume}}{\text{the necessary pressure change}}$$

therefore:

$$K = \frac{-1}{V} \times \frac{\Delta V}{\Delta p}$$

The constant volume delivery can be seen as a stepwise displacing of liquid out of the pump head. The dimension for the volume delivery is the amount of piston volume during a period of time. But this is only correct as long as the delivery is done without any added pressure. As soon as the liquid delivery has to be done against a back pressure, a specific amount of the piston volume has to be used for compressing the liquid first, before the actual delivery can start.

This can be described by the following diagram:

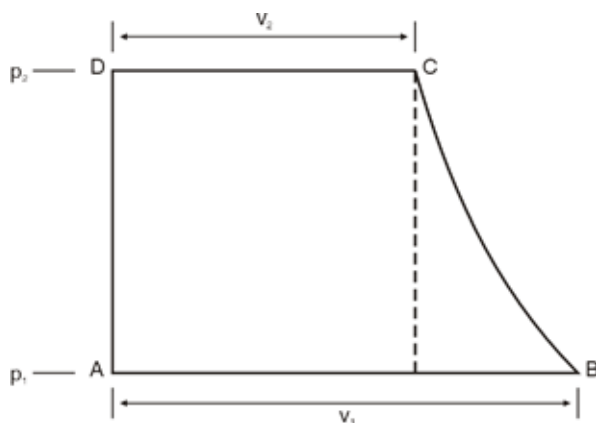

#	Element
V1	suction volume
p1	suction pressure
V2	delivery volume
p2	delivery pressure

A to B	suction of liquid during pressure p1
B to C	compressing the liquid from p1 to p2
C to D	delivery against pressure p2
D to A	changing from delivery to suction

The compressibility will effect the constant of the liquid delivery depending on the pressure. To overcome this problem, the S 9432 is using a calculation program to correct the pressure depending change of the flow rate. This calculation program corrects the compressibility as well as the always existing leakage rate of the check valves, in relation to the actual pressure. The processor is checking the back pressure every 0.1 seconds and corrects the piston speed accordingly.

The calculation program is using the liquid with the smallest compressibility (water) as a factor of 1.

As different organic solvents are showing a different compressibility, the processor needs this information for the most accurate delivery rate. This information can be added through the Compressibility Factor in the menu. As water has been normalized to the factor of 1, all others have to be smaller than 1.

The following table shows the Compressibility Factors of the mostly used solvents:

<i>Solvent</i>	<i>Compressibility</i>
Water	1.000
Methanol	0.630
Ethanol	0.740
Propanol	0.720
Butanol	0.750
Acetonitrile	0.680
Chloroform	0.580
Buffer Solutions	1.000

For solvent mixtures of different organic solvents, the constant can be calculated by adding the constants of the different solvents in relation to their percentage in the mixture.

For example: 50% H₂O, 20% Methanol, 30% Acetonitril

$$F = 0.5 F(\text{H}_2\text{O}) + 0.2 F(\text{Methanol}) + 0.3 F(\text{Acetonitril})$$

$$F = 0.5 \times 1.0 + 0.2 \times 0.63 + 0.3 \times 0.68$$

$$F = 0.83$$

For other solvents with an unknown factor, an average factor of 0.700 can be used. The difference from the correct delivery rate won't be higher than 5%. If this accuracy is good enough, a medium factor of 0.700 for all organic solvents and 1.000 for water can be used.

APPENDIX B: SPECIFICATIONS

B.1 Technical Specifications

B.1.1 Vacuum Chamber (optional)

# of Channels:	1, 2, 3, or 4
Degassing Technique:	Applied vacuum through semipermeable membrane
Wetted Materials:	Teflon AF®, Stainless Steel / PEEK*
Volume per Channel:	< 500 µl
Inner Diameter (Capillary):	1.1 mm
Degassing Efficiency:	< 20% dissolved gases remaining in water at 1.0 ml/min*

B.1.2 Vacuum Pump (optional)

Mechanism:	Stepper Motor driven membrane pump
Wetted Material (Fumes only):	Teflon, Aluminium, EPDM

B.1.3 Pump

Wetted Materials:	Stainless Steel / PEEK*, PVDF, Ceramics, Ruby
Flow Rate:	Micro: 0.001 - 4.000 ml/min Analytical: 0.001 - 10.000 ml/min Semi-Preparative: 0.001 - 40.000 ml/min
Flow Accuracy:	± 1.0 % @ 1.000 ml / min
Flow Precision:	± 0.1 % RSD @ 1.000 ml/min
Gradient Mixing:	Dynamic; 516 - 923 µl adjustable mixing volume
Pressure Range:	0 – 40 MPa (0 – 6000 PSI)
Pressure Pulsation:	typical < 0.1 MPa or < 1.0 %
Dimensions:	310 x 165 x 478 mm (W x H x D)
Weight:	7.0 kg
Power Supply:	100 – 250 ~V, 47 – 63 Hz, 20 W

* depending on material option

B.2 Environmental Conditions

B.2.1 Operational Conditions

Ambient Temperature:	+10 °C to +35 °C
Ambient Relative Humidity:	20 to 80 % RH (non-condensing)

B.2.2 Storage Conditions

Ambient Temperature:	-20 °C to +60 °C
Ambient Relative Humidity:	20 to 80 % RH (non-condensing)

APPENDIX C: ACCESSORIES

C.1 Standard Accessories

The *S 9432 HPLC Pump System* is delivered with the following standard accessories:

- 1x Power Cord (EU Type)
- 1x Serial Cable (RS-232)
- 2x 1/8" Capillary, FEP (2 m)
- 2x 1/8" Fitting & Ferrule, PVDF
- 1x 1/16" Capillary, I.D. 0.50mm, 60 cm (SS or PEEK)
- 1x Wrench, 12 x 13mm
- 1x Wrench, 1/4" x 5/16"
- 1x Allen Wrench, 2.5mm
- 1x Allen Wrench, 3.0mm
- 1x Plastic Syringe w. Tubing Adapter
- 1x Operation Manual (this)
- 2x Fuse, 2 A

APPENDIX D: VERSION CONTROL

D.1 Version History

The *S 9432 HPLC Pump System Operation Manual* is subject to version control. The version history is continued and noted on every document. The access to the original document is restricted to the creating party. The document is subject to periodical checks and can never reach an unchangeable state.

<i>Version</i>	<i>Release Date</i>	<i>Description</i>
1.0	2014-05-26	First Release

