

Precision Syringe Pumps

Teledyne Isco D-Series Syringe Pumps

Models 65D 65DM 100DM 100DX 260D 500D 1000D

See separate literature for HL Series Hazardous Location Pumps.



- **Precision Fluid Metering**
- **Precision Pressure Control**
- **Reactant Feed**
- **Core Flooding**
- **Supercritical Fluids**
- **HPLC and Ultra-HPLC**



TELEDYNE ISCO

A Teledyne Technologies Company

www.isco.com

D-Series Overview

When reliability & accuracy are critical . . .

. . . Teledyne Isco D-Series precision syringe pumps give you flow and pressure control throughout a remarkable operating range. D-Series pumps do not exhibit pulsation or flow anomalies typically associated with other pump types. They can handle a wide variety of fluids including:

- aqueous and organic liquids
- corrosive solutions
- liquefied gases
- slurries and pastes
- All can be metered with great accuracy
- heated fluids
- viscous fluids

Seven Pump Choices: 65D, 65DM 100DM, 100DX, 260D, 500D, 1000D

These seven module sizes provide flow rates from:

- sub-microliter/minute to over 400 ml/minute
- pressures from atmospheric 1,390 Bar (20,000 psi)



Single Pump System



Dual Pump System With Air Valves



Three Pump System

Three Configurations: single, dual or three pump

Up to three pumps can be operated with one controller.

- Single pump - constant flow, constant pressure or dispensing
- Dual pump - continuous constant flow or pressure
- Three-pump - independent constant flow or pressure

Pump & Controller



Exclusive "Smart Key" Controller

All D-Series pumps, regardless of configuration or operating mode, utilize the same controller, which can be operated up to 50 feet from the pump modules with optional extension cables. "Smart key" programming makes setting up and running your pump system easy and can be learned in just a few minutes. All functions are accessible from the front panel and parameters, such as status, flow rate and pressure, are continuously displayed.

You have one button access to:

- Start or stop
- Dispense mode
- Operating parameters such as flow rate, pressure or refill
- Accessory functions

Configured menus provide user-selectable options for:

- Modes of operation
- Operating units
- Valve selection
- External interface control
- And much more

Multiple pumps can be controlled with a single program, a configured program, or independently with varied programs.

Large Selection of Operating Modes

- Constant flow
- Constant pressure
- Flow or pressure gradients
- Dispensing
- Receiving
- Dual pump concentration gradients

CPa	0.000mL/MIN	-18PSI	507.37mL
CYLINDER FULL			00:00:00
10PSI			SELECT
PRESSURE			PUMP



Operate two or three pump modules independently from one controller. Parameters for each pump are individually displayed.

Outstanding Mechanical Features

Isco pumps use digital positioning servo control circuitry, for low-flow precision at any pressure, plus the high speed smoothness and power of a DC motor.

Our rugged single-ratio drive train is designed for long life with auto-lubricating gears and other low maintenance components.

Nitronic 50, the standard material for cylinders, pistons, and caps, is an austenitic stainless steel with outstanding strength and corrosion resistance. Standard piston seals are heavy-duty, graphite impregnated Teflon, providing long life under harsh operating conditions.

The built-in pressure transducer assures excellent stability and repeatability.

Redundant Safety is Designed In

All D-Series pumps have mechanical and electrical fail-safes, in addition to the factory default or user-set limits. The pump controller monitors motor speed and cylinder pressure, and automatically shuts down if either exceeds the default (or user-set) flow and pressure limits. Motor current is limited to 6 amps, and is continuously monitored for over-current situations. Every pump has a drive screw shear key designed to fail if pressure exceeds the pump's maximum rating by 20%.

Single-pump Systems

Superior Operating Temperature Range

With proper options, pump cylinders can be heated to:

- 200°C or cooled to -20°C.

Our temperature control jackets are especially useful for supercritical fluids or ultra-low flow rates, allowing you to maintain a constant temperature throughout the cylinder. This optimizes your pump's ability to provide an accurate flow rate or pressure setpoint.

Minimal Flow Noise

Teledyne Isco syringe pumps are inherently pulseless, and residual flow noise is virtually undetectable. In an independent comparison of flow noise for ultra-sensitive electrochemical HPLC detection, our pump was 10 to 20 times quieter than a supposedly "pulse-free" micro volume pump.

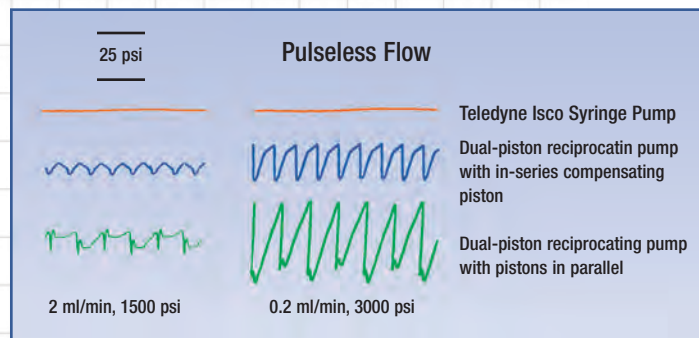

Stable and Precise Flow Rates

D-Series pumps used in single pump systems are capable of providing accurate, pulseless flow to any application from as low as 0.00001 ml/min. With large capacity cylinders (up to 1 liter), a single pump system can deliver fluids with sub-microliter accuracy or pinpoint pressure control into small-scale batch processes, bench-scale development, and other limited volume applications.

Precision Transducer is Standard

A new "button" type pressure transducer is internal to the pump cap.

- Compatible with most solvents, supercritical fluids, brine solutions, and other aggressive fluids
- 0.5% full scale accuracy
- 1°C to 40°C operating range

Options are available for high temperatures, 0.1% linear accuracy, and inert alloys.

Fast refill for quick cycle time

Every D-Series pump can refill in 3.5 minutes or less, depending on cylinder volume. Even at this speed, the refill cycle is slow enough to avoid cavitation of most volatile fluids without pre-pressurizing.

Or, you can set the refill speed to any value within pump specifications. Whether dispensing or refilling, your pump can operate automatically at its maximum capabilities - at the time or volume you desire.

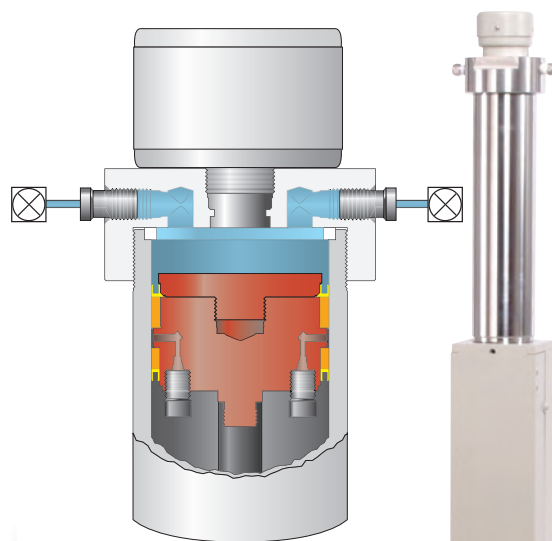

Single pump diagram

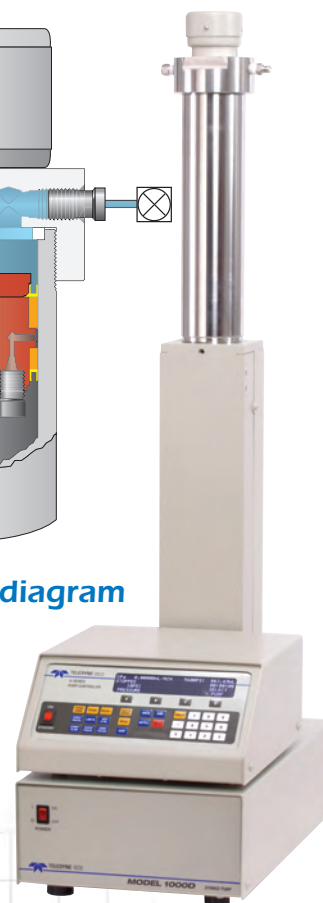

To see Isco pumps in action and to tell us about your needs and interests visit www.isco.com/pump

Dual-pump Systems

Continuous Feed at up to 300 ml/min

Isco continuous flow systems couple two pump modules to a single controller, and utilize an active or passive valve manifold to provide non-stop, continuous feed of almost any fluid. The controller uses special algorithms to equalize pressure and flow of both pumps during switchover. This allows virtually pulseless transition while maintaining accurate fluid injection to the process. And, it's totally automatic. Program your flow or pressure set point, refill speed, and any parameter limits if necessary. Then, fill the pumps and you are set to go.

Valve Packages

Our valve packages can accommodate a wide variety of fluids in most applications. You can also control any valve system that requires +15Vdc directly from the pump.

Air-Powered Valves

Dual-pump systems, with actively controlled pneumatic valves, work reliably with almost any fluid,

including viscous and/or corrosive solutions. Air valves are constant volume; there is no fluid movement when they open and close. Valves can be heated to 160°C.

NOTE: An 80 to 100 psi air source is required to operate this package.

Electric Valves

Electric valves are driven by the pump controller, and require no outside air source or other power supply. Valves are stem-and-ball type, very reliable, and feature a unique one-way flow path design, which offers added protection against catastrophic back flow. This valve is capable of handling a wide range of corrosive fluids, liquefied gasses, volatile fluids, and viscous solutions. Valves can be heated to 150°C.

Economical Check Valve Systems

This passive check valve package features double ball-and-seat arrangements in each cartridge, delivering cost-effective continuous feeding. Check valve systems require low viscosity, clean fluids, and downstream pressure 200 psi greater than pump refill pressure.

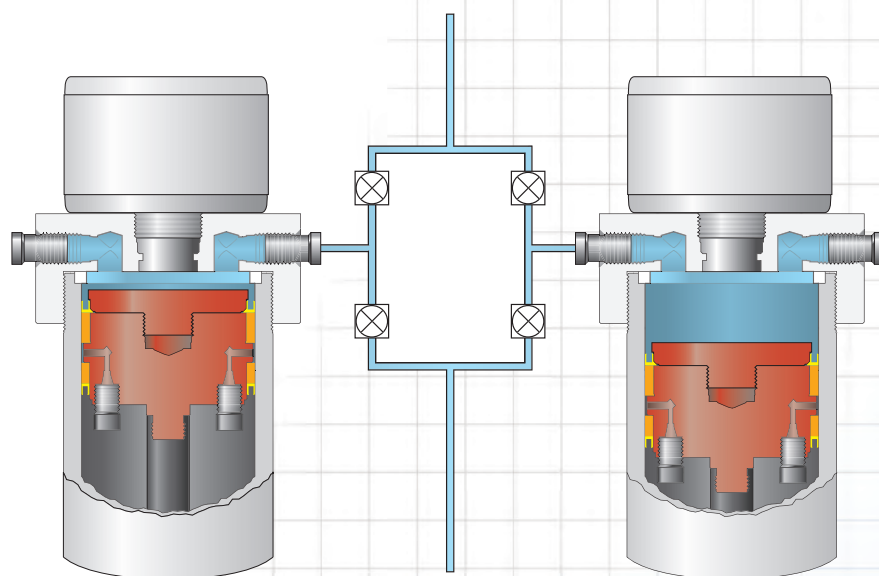

Dual-pump diagram

Options & Accessories

In order to provide you with a broad variety of choices for configuring and operating Teledyne Isco pump systems, we offer the following items. Most are available to be retrofitted on site. If and when your needs change, contact us for assistance with selection and ordering.

Custom Pumps and Controls

We can provide custom pump designs and controls tailored to your requirements. We've written many versions of application-specific firmware for pump control. Chances are, we already have what you need. If none of our standard pump models quite fit your application, simply contact a Teledyne Isco Product Specialist. We will investigate the ability of our pumps and controls to fill your need, then send you an up-front quote detailing changes, new features, and cost.

Ultimate Corrosion Resistance

Many applications require delivery of highly corrosive fluids. Isco offers pump packages with cylinder, cap, and piston made from Hastelloy C-276 to provide increased corrosion resistance when pumping acids, salt solutions, or other caustic fluids. These packages can be factory-installed, or ordered separately so you may upgrade existing hardware. Other alloys are also available – check with your Isco Product Specialist for the right alloy package for your application.

Air Valves

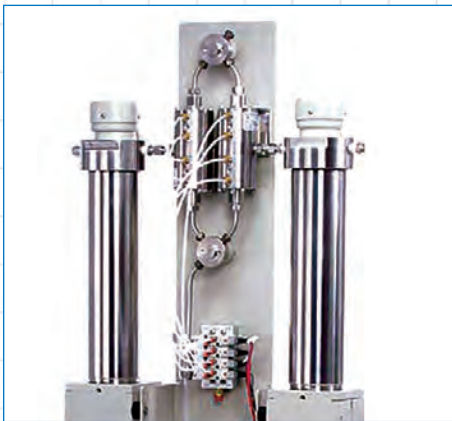

Electric Valves

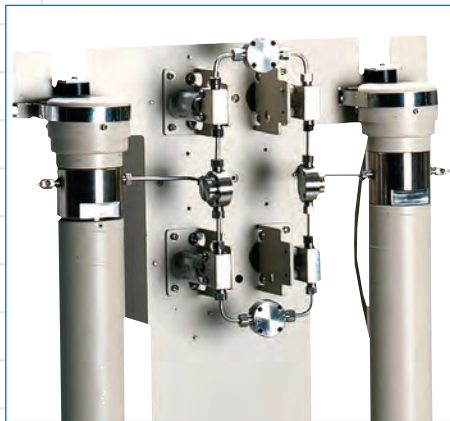

Electric Valves (single pump)

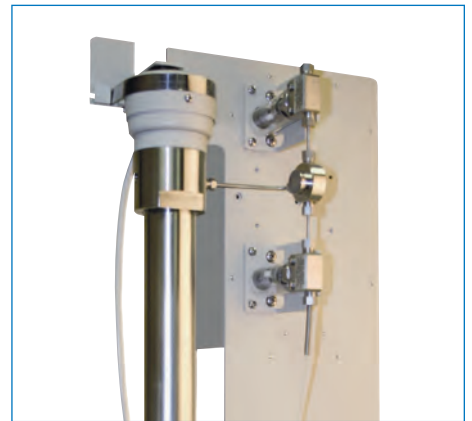

Dual-pump Valve Packages

Manual valves, electric valves, air valves, or check valves; we have the right valve in the right configuration to make your inlet and outlet connections, we offer single or dual-

pump designs, and our pump controller can operate all of the active valve packages. Valves come in 1/16, 1/8, and 1/4 inch porting to match your fluid requirements.

Single-pump Valve Packages

In addition to dual pump valve packages, we also offer air valves, electric valves or manual valves for single pump operation to automate your process. These valves also come in 1/16, 1/8, and 1/4 inch porting.

Options & Accessories



0.1% Accuracy Transducers

For pinpoint pressure control, we offer high accuracy (0.1% full scale) precision transducers from Honeywell/Sensotec. Modified for use with your D-Series pump, these transducers plug into the transducer connector on the pump.



High-temperature Transducer

Suitable for operation to 200°C, this package includes a Honeywell/Sensotec TJE high-temperature transducer, a new cap assembly, and special high-temperature seals.



Temperature Control Jacket

Controls cylinder temperature by insulating heated or cooled fluid. Cylinder cooling allows fast, complete filling with a liquefied gas and is recommended when a continuous flow system is used for rapid delivery of such fluids. Temperatures range from -30°C to 100°C.



Cylinder Insulating Cover

Reduces ambient temperature effects for best flow stability at low flow rates (below about 0.05% of the maximum flow on any pump model).

Note: Not compatible with dual pump continuous flow systems.

Analog Interfaces

Voltage Output: For data loggers requiring analog voltage signals, an optional card can be installed in the Series D controller to provide 0 to 10VDC, 0 to 5VDC, and -5 to +5VDC outputs for flow rate and volume remaining in pump. This interface works in all pump modes.



Analog Input: 4-20 mA Input Converter: This separate module can process 4-20 mA inputs for up to three pump modules. It converts 4-20 mA signals used in your control system into signals that are compatible with the Series D pump controller inputs.



Analog Output: 4-20 mA Output: This internal card provides 4-20 mA outputs for monitoring flow rate, pressure, and volume remaining. It works in all pump modes.

Seals



We carry a wide variety of seals to fit almost any application; virgin Teflon for corrosive fluids; heavy duty reinforced for slurries and viscous fluids; high temperature, low temperature and UHMW polyethylene. Your choice of seals can be ordered factory-installed in your pump system.

Specifications



Tested and Certified



Each Isco D-Series syringe pump is bench tested at the factory, prior to delivery. All pumps are UL certified to UL 3101 and EN 61010-1 standards. They are UL listed and CE compliant.

	1000D	500D	260D	100DX	100DM	65DM	65D
Pump Modules							
Capacity	1015 ml	507 ml	266 ml	103 ml	103 ml	67 ml	67 ml
Flow Range (ml/min)	0.100-408	0.001-204	0.001-107	0.00001-50	0.00001-25	0.00001-25	0.00001-25
Flow Accuracy	0.5% of Setpoint			0.3% of Setpoint			
Pressure Range (psi)	10-2,000	10-3,750	10-7,500	10-10,000	10-10,000	10-10,000	10-20,000
Standard Pressure Accuracy	0.5% FS						
Standard Plumbing Ports	1/4" NPT	1/8" NPT	1/8" Valco			1/4" F250C	
Standard Temperature Range	5 - 40°C Ambient						
Power	100 Vac, 117 Vac, 234 Vac, 50/60 Hz						
Dimensions	Height: 103 cm (40.5 in), Width: 27 cm (10.6 in), Depth: 47 cm (18.5 in)						108 cm
Dual-pump Systems							
Flow Range* (ml/min)	0.1-300	0.00 1-138	0.001-80	0.00001-45	0.00001-22	16	16
Pump controller							
Operating Modes	Single pump, constant flow or pressure Dual pump, constant flow or pressure Single pump, flow or pressure programming Dual pump, flow or pressure gradients 3-pump independent operation 3-pump continuous flow w/modifier						
Memory	200 programmable steps						
External Interfacing	RS-232, analog voltage inputs, digital contact closure for RUN/STOP, REFILL/DELIVER. 4-20 mA In/Out, and analog voltage output options available.						

* Maximum and minimum flows are dependent on optimizing your pump system. Consult an Isco product specialist to determine the best method for your application. For additional information, please consult the factory. Isco is continually improving its products and reserves the right to change specifications without notice. All brand or product names mentioned herein are trademarks or registered trademarks of their respective holders.

To learn more about Teledyne Isco D-Series or HL-Series hazardous location pumps, visit

www.isco.com



TELEDYNE ISCO

A Teledyne Technologies Company

4700 Superior Street
Lincoln, NE 68504 USA

Toll free: (800)228-4373 (USA & Canada) • Phone: (402)464-0231 • Fax: (402)465-3022 • e-mail: info@isco.com

Brochure L-7101 • Printed in the U.S.A. • All rights reserved. • Revised 11/11