



Front: QCLs
Back: Set-up examples with exclusive accessories

Quantum Cascade Laser

Quantum Cascade Lasers are semiconductor lasers that offer peak emission in the mid-IR range (4 μm to 10 μm). They have gained considerable attention as a new light source for mid-IR applications such as molecular gas analysis.

- **Features**
 - Mid-IR laser (4 μm to 10 μm)
 - Compact, lightweight
- **Applications**
 - Trace gas analysis Environmental measurement, Combustion gas measurement, Plasma measurement, In vivo gas analysis
 - IR molecular spectroscopy Chemical sensing, Molecular oscillation

■ CW Quantum Cascade Lasers

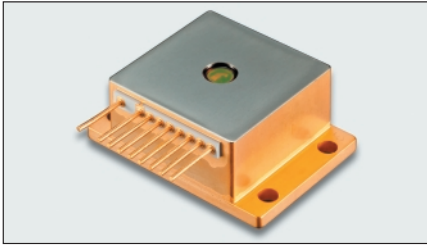

HHL package

Quantum Cascade Lasers use Single Photon Continuum depopulation and Distributed Feedback (DFB) structures to emit Continuous Wave (CW) mid-IR laser light under room temperature.

By controlling the chip's operating temperature through the Peltier element installed in the HHL package, it is possible to tune the emission wavelength without mode hopping while keeping longitudinal single mode operation.

Type No.	Wavelength ^(*)	Operating temperature (QCL) ^(**)		Line width ^(***)	Tunable range ^(***)	Output power	Threshold current	Side-mode suppression ratio (SMSR)
	Typ.	Min.	Max.	Max.	Min.	Min.	Max.	Min.
L12004-2310H-C	4.33 μm	+10 °C	+50 °C	0.2 cm ⁻¹ ^(***)	±1.0 cm ⁻¹	20 mW	1.0 A	25 dB
Condition: K=2310 cm ⁻¹ ^(***)								
L12004-2209H-C	4.53 μm	+10 °C	+50 °C	0.2 cm ⁻¹ ^(***)	±1.0 cm ⁻¹	20 mW	1.0 A	25 dB
Condition: K=2209 cm ⁻¹ ^(***)								
L12004-2190H-C	4.57 μm	+10 °C	+50 °C	0.2 cm ⁻¹ ^(***)	±1.0 cm ⁻¹	20 mW	1.0 A	25 dB
Condition: K=2190 cm ⁻¹ ^(***)								
L12005-1900H-C	5.26 μm	+10 °C	+50 °C	0.2 cm ⁻¹ ^(***)	±1.0 cm ⁻¹	20 mW	1.0 A	25 dB
Condition: K=1900 cm ⁻¹ ^(***)								
L12006-1631H-C	6.13 μm	+10 °C	+50 °C	0.2 cm ⁻¹ ^(***)	±1.0 cm ⁻¹	20 mW	1.0 A	25 dB
Condition: K=1631 cm ⁻¹ ^(***)								
L12007-1392H-C	7.18 μm	+10 °C	+50 °C	0.2 cm ⁻¹ ^(***)	±1.0 cm ⁻¹	20 mW	1.0 A	25 dB
Condition: K=1392 cm ⁻¹ ^(***)								
L12007-1354H-C	7.39 μm	+10 °C	+50 °C	0.2 cm ⁻¹ ^(***)	±1.0 cm ⁻¹	20 mW	1.0 A	25 dB
Condition: K=1354 cm ⁻¹ ^(***)								
L12007-1294H-C	7.73 μm	+10 °C	+50 °C	0.2 cm ⁻¹ ^(***)	±1.0 cm ⁻¹	20 mW	1.0 A	25 dB
Condition: K=1294 cm ⁻¹ ^(***)								

(*) Please contact a Hamamatsu sales office about QCLs with emission wavelengths not listed above.

(**) This specifies the temperature range within which the target emission wavenumber (K) can be realized.

(***) Full-width half maximum

(***) This specifies the continuous tunable range (without mode hopping). The center wavenumber of the tuning range is the emission wavenumber (K).

(***) The figures are limited by the resolution and signal/noise ratio of the measuring instruments used.

(***) K: Emission wavenumber (cm⁻¹)

Dimensional outline (unit: mm)

HHL package

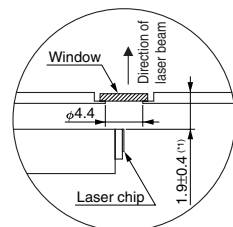
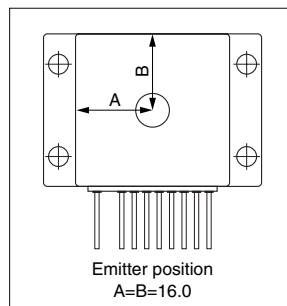
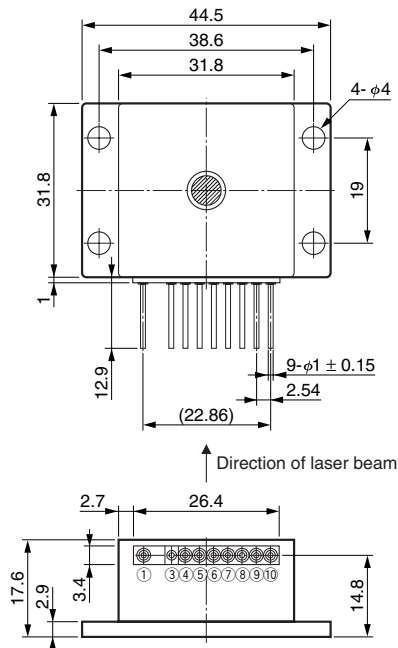

* Tolerance is +/- 0.3 mm unless specified.

(*) Edge of QCL chip and outside of the package

PIN No. ^(*)	FUNCTION	PIN No. ^(*)	FUNCTION
①	TEC Cathode (-)	⑦	QCL Cathode (-)
③	N.C.	⑧	Thermistor (Top(c))
④	QCL Anode (+)	⑨	Thermistor (Top(qcl))
⑤	Thermistor (Top(qcl))	⑩	TEC Anode (+)
⑥	Thermistor (Top(qcl))	—	—

(*) ③ is electrically connected to the package. The other pins are electrically isolated from the package.

Characteristics examples

●L12004-2310H-C

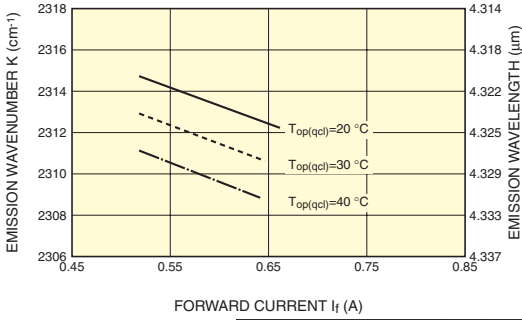

Parameter	Symbol	Condition	Typical value
Temperature coefficient of wavenumber	δK_T	I_f fixed	-0.18 $\text{cm}^{-1}/^\circ\text{C}$
Current coefficient of wavenumber	δK_C	$T_{op(qcd)}$ fixed	-0.017 cm^{-1}/mA

●L12004-2209H-C

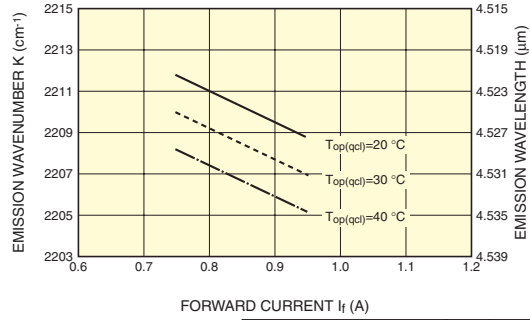

Parameter	Symbol	Condition	Typical value
Temperature coefficient of wavenumber	δK_T	I_f fixed	-0.18 $\text{cm}^{-1}/^\circ\text{C}$
Current coefficient of wavenumber	δK_C	$T_{op(qcd)}$ fixed	-0.015 cm^{-1}/mA

●L12004-2190H-C

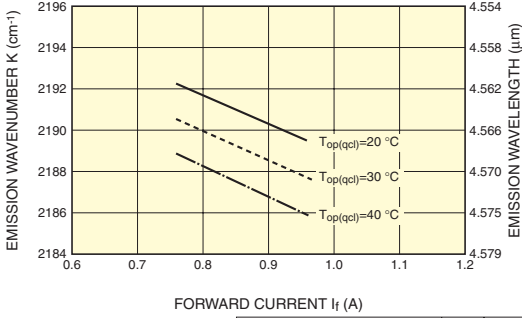

Parameter	Symbol	Condition	Typical value
Temperature coefficient of wavenumber	δK_T	I_f fixed	-0.18 $\text{cm}^{-1}/^\circ\text{C}$
Current coefficient of wavenumber	δK_C	$T_{op(qcd)}$ fixed	-0.015 cm^{-1}/mA

●L12005-1900H-C

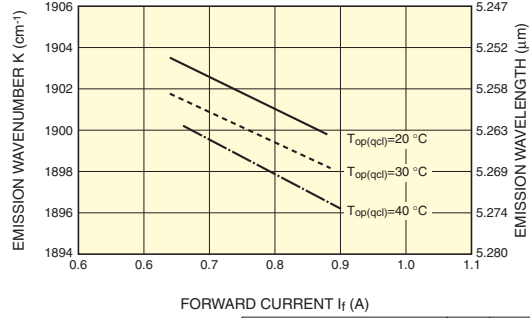

Parameter	Symbol	Condition	Typical value
Temperature coefficient of wavenumber	δK_T	I_f fixed	-0.14 $\text{cm}^{-1}/^\circ\text{C}$
Current coefficient of wavenumber	δK_C	$T_{op(qcd)}$ fixed	-0.016 cm^{-1}/mA

●L12006-1631H-C

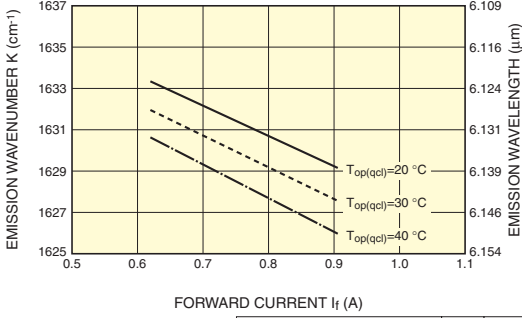

Parameter	Symbol	Condition	Typical value
Temperature coefficient of wavenumber	δK_T	I_f fixed	-0.15 $\text{cm}^{-1}/^\circ\text{C}$
Current coefficient of wavenumber	δK_C	$T_{op(qcd)}$ fixed	-0.015 cm^{-1}/mA

●L12007-1392H-C

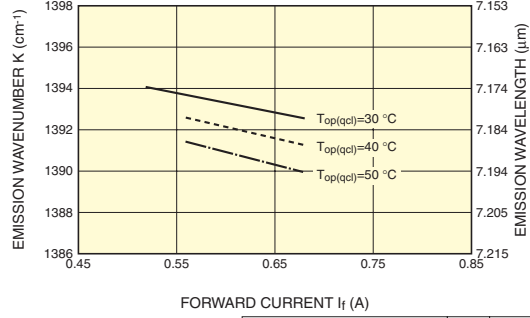

Parameter	Symbol	Condition	Typical value
Temperature coefficient of wavenumber	δK_T	I_f fixed	-0.12 $\text{cm}^{-1}/^\circ\text{C}$
Current coefficient of wavenumber	δK_C	$T_{op(qcd)}$ fixed	-0.01 cm^{-1}/mA

●L12007-1354H-C

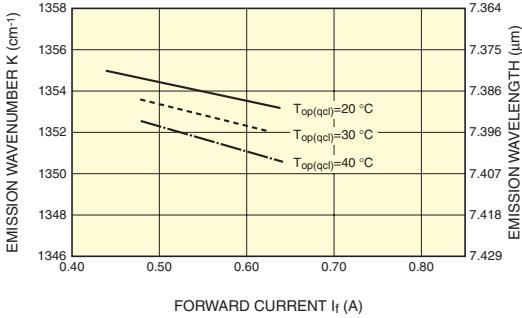

Parameter	Symbol	Condition	Typical value
Temperature coefficient of wavenumber	δK_T	I_f fixed	-0.12 $\text{cm}^{-1}/^\circ\text{C}$
Current coefficient of wavenumber	δK_C	$T_{op(qcd)}$ fixed	-0.01 cm^{-1}/mA

●L12007-1294H-C

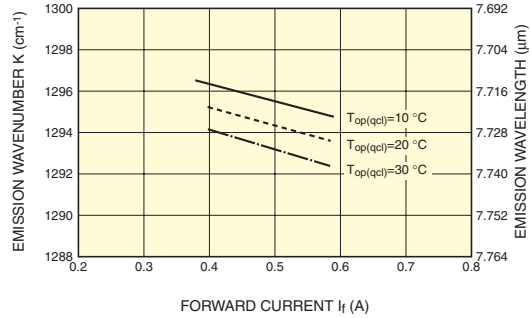

Parameter	Symbol	Condition	Typical value
Temperature coefficient of wavenumber	δK_T	I_f fixed	-0.1 $\text{cm}^{-1}/^\circ\text{C}$
Current coefficient of wavenumber	δK_C	$T_{op(qcd)}$ fixed	-0.01 cm^{-1}/mA

CLASS 3B LASER

Invisible Laser Radiation: Avoid Exposure to Beam

●The Laser emits invisible laser radiation. The instrument which used the LASER, operated under ordinary conditions, is classified as Class 3B according to the laser product classification code IEC 60825-1. See IEC 60825-1, -14 for more details and safety operation concerning the above countermeasures.

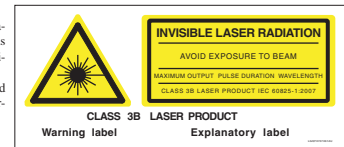

QCL LINEUP

■ CW Quantum Cascade Laser (built-in lens)

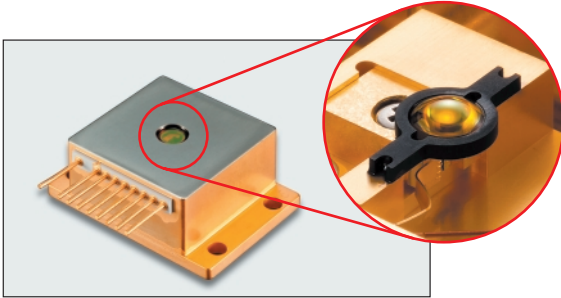

HHL package

The lens integrated package for DFB-CW type QCL is sealed and collimated housing. Internal lens provides collimated output beam radiation. TEC (peltier) and thermistor for temperature stabilization of QCL-laser chip are inside the housing.

The lens integrated package allows to use under good usability without beam alignment of invisible mid-infrared laser.

Type No.	Wave-length ^{(*)1}	Operating temperature (QCL) ^{(*)2}		Line width ^{(*)3}	Tunable range ^{(*)4}	Output power	Threshold current	Side-mode suppression ratio (SMSR)	Beam spread angle ^{(*)5)(*)6}	Beam waist location ^{(*)5)(*)7}		Width of beam at waist ^{(*)5)(*)8}
	Typ.	Min.	Max.	Max.	Min.	Min.	Max.	Min.	Typ.	Min.	Max.	Typ.
L12004-2190H-E	4.57 μm	+10 °C	+50 °C	0.2 cm ⁻¹ (*)9	±1.0 cm ⁻¹	20 mW	1.0 A	25 dB	3 mrad	50 mm	1000 mm	1.5 mm
Condition: K=2190 cm ⁻¹ (*)10							Condition: Top(qcl)=20 °C					

(*)1 Please contact a Hamamatsu sales office about QCLs with emission wavelengths not listed above.

(*)2 This specifies the temperature range within which the target emission wavenumber (K) can be realized.

(*)3 Full-width half maximum

(*)4 This specifies the continuous tunable range (without mode hopping). The center wavenumber of the tuning range is the emission wavenumber (K).

(*)5 This product has individual difference. Confirm date sheet attached to a product.

(*)6 Half angle beam spread from the perpendicular (Fast) direction (perpendicular to pins) or horizontal (Slow) direction (parallel to pins), whichever is wider.

(*)7 From package top surface

(*)8 1/e² beam radius

(*)9 The figures are limited by the resolution and signal/noise ratio of the measuring instruments used.

(*)10 K: Emission wavenumber (cm⁻¹)

Characteristics examples

● L12004-2190H-E

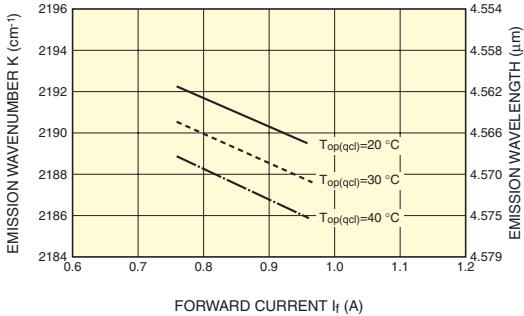

Parameter	Symbol	Condition	Typical value
Temperature coefficient of wavenumber	δK _T	I _f fixed	-0.18 cm ⁻¹ /°C
Current coefficient of wavenumber	δK _C	T _{op(qcl)} fixed	-0.015 cm ⁻¹ /mA

Typical beam profile

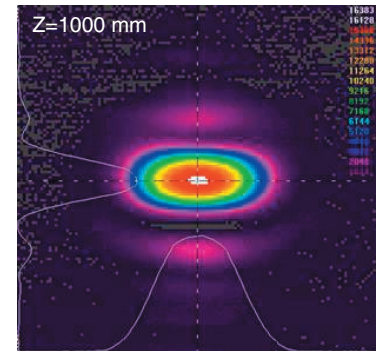

Dimensional outline (unit: mm)

HHL package

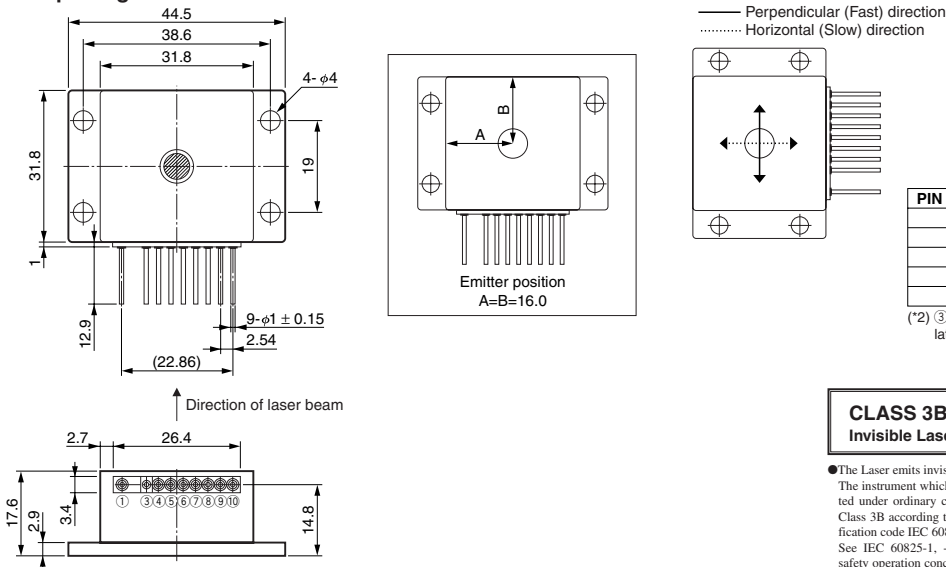

PIN No. (*)3	FUNCTION	PIN No. (*)3	FUNCTION
①	TEC Cathode (-)	⑦	QCL Cathode (-)
③	N.C.	⑧	Thermistor (Top(c))
④	QCL Anode (+)	⑨	Thermistor (Top(qcl))
⑤	Thermistor (Top(qcl))	⑩	TEC Anode (+)
⑥	Thermistor (Top(qcl))	—	—

(*)3 ③ is electrically connected to the package. The other pins are electrically isolated from the package.

CLASS 3B LASER

Invisible Laser Radiation: Avoid Exposure to Beam

● The Laser emits invisible laser radiation. The instrument which used the LASER, operated under ordinary conditions, is classified as Class 3B according to the laser product classification code IEC 60825-1. See IEC 60825-1, -14 for more details and safety operation concerning the above countermeasures.

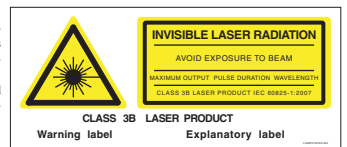

CONNECTION EXAMPLE

DFB-CW QCL

- ① DFB-CW QCL (L12004, L12005, L12006, L12007 Series)
- ② TEC Driver C11330-01
- ③ Forced Air Cooling HHL Mount A11709-01 or Water Cooling HHL Mount A11709-02
- ④ Aspheric ZnSe lens A11331-02 and/or Lens unit A11331-02H (*1)
- ⑤ Cable A11134-04
- ⑥ Laser Power Supply (Use DC power supply designed for CW semiconductor laser available in market.)
- ⑦ Cable A11134-05
- ⑧ Heatseeker A10767

(*1) Select suitable lens based on the emission wavelength of the QCL to use.

DFB-CW QCL (built-in lens)

- ① DFB-CW QCL (L12004-2190H-E)
- ② TEC Driver C11330-01
- ③ Forced Air Cooling HHL Mount A11709-01 or Water Cooling HHL Mount A11709-02
- ④ Cable A11134-04
- ⑤ Laser Power Supply (Use DC power supply designed for CW semiconductor laser available in market.)
- ⑥ Cable A11134-05
- ⑦ Heatseeker A10767

Connection example of DFB-CW QCL

..... Our products

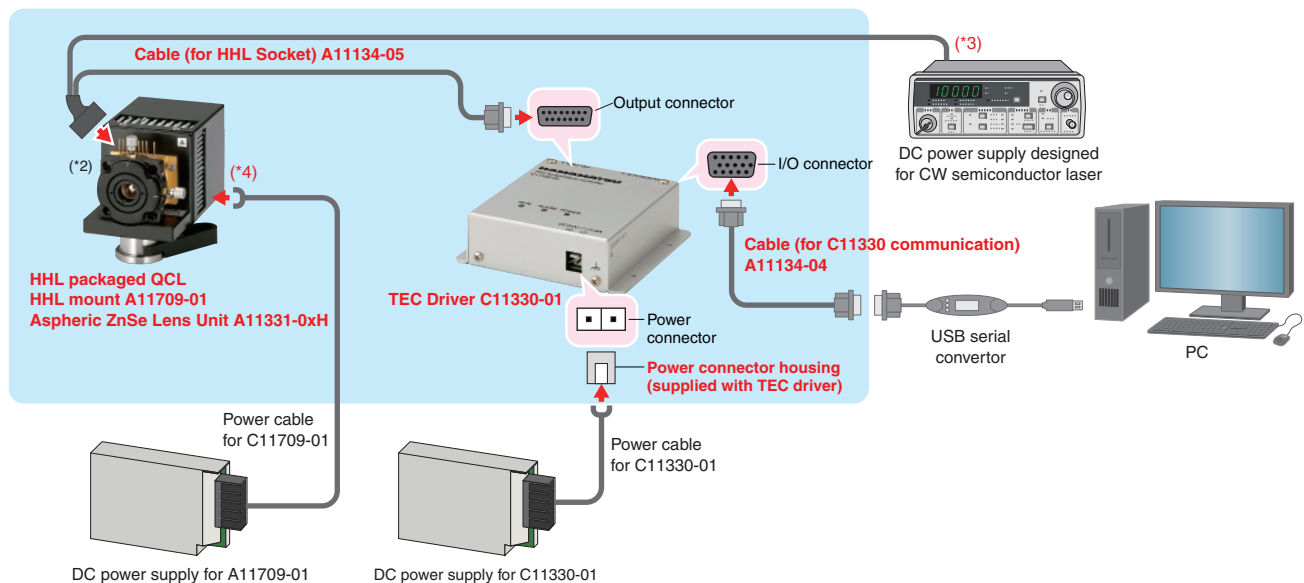

(*2) The photo is HHL Mount C11709-01 mounting a HHL packaged QCL and a Aspheric ZnSe Lens Unit A11331-0xH.

(*3) One end of the cable for CW semiconductor laser that connects to the DC power supply is unterminated and so should be properly terminated by the user.

(*4) Connect to the cooling fan 2-pin red/black cord of the A11709-01.

· Products shown in photos are Hamamatsu products. Product names and part numbers are written in red.

· Prepare additional devices and cables separately.

■ Pulsed Quantum Cascade Lasers

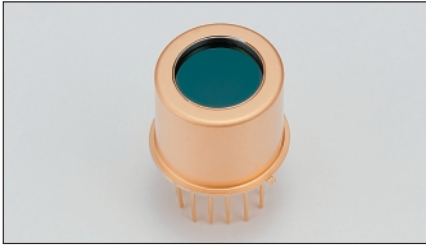

TO-8 package

Quantum Cascade Lasers use Single Photon Continuum depopulation and Distributed Feedback (DFB) structures to emit pulsed mid-IR laser light under room temperature.

By controlling the chip's operating temperature through the Peltier element installed in the TO-8 package, it is possible to tune the emission wavelength without mode hopping while keeping longitudinal single mode operation.

Type No.	Wavelength ^{(*)1}	Operating temperature (QCL) ^{(*)2}		Line width ^{(*)3}	Tunable range ^{(*)4}	Pulsed output power	Threshold current	Side-mode suppression ratio (SMSR)
	Typ.	Min.	Max.	Max.	Min.	Min.	Max.	Min.
L12014-2231T-C	4.48 μm	-10 °C	+50 °C	0.2 cm ⁻¹ ^{(*)5}	±1.0 cm ⁻¹	50 mW	1.5 A	25 dB
Condition: K=2231 cm ⁻¹ ^{(*)6}								
L12015-1901T-C	5.26 μm	-10 °C	+50 °C	0.2 cm ⁻¹ ^{(*)5}	±1.0 cm ⁻¹	50 mW	1.5 A	25 dB
Condition: K=1901 cm ⁻¹ ^{(*)6}								
L12016-1630T-C	6.13 μm	-10 °C	+50 °C	0.2 cm ⁻¹ ^{(*)5}	±1.0 cm ⁻¹	50 mW	1.5 A	25 dB
Condition: K=1630 cm ⁻¹ ^{(*)6}								
L12017-1278T-C	7.82 μm	-10 °C	+50 °C	0.2 cm ⁻¹ ^{(*)5}	±1.0 cm ⁻¹	50 mW	1.5 A	25 dB
Condition: K=1278 cm ⁻¹ ^{(*)6}								
L12020-0993T-C	10.07 μm	-10 °C	+50 °C	0.2 cm ⁻¹ ^{(*)5}	±1.0 cm ⁻¹	50 mW	1.5 A	25 dB
Condition: K=993 cm ⁻¹ ^{(*)6}								

Standard driving conditions: $t_w=50$ ns, $f_r=200$ kHz, $T_{op(qcl)}=20$ °C

(*)1 Please contact a Hamamatsu sales office about QCLs with emission wavelengths not listed above.

(*)2 This specifies the temperature range within which the target emission wavenumber (K) can be realized.

(*)3 Full-width half maximum

(*)4 This specifies the continuous tunable range (without mode hopping). The center wavenumber of the tuning range is the emission wavenumber (K).

(*)5 The figures are limited by the resolution and signal/noise ratio of the measuring instruments used.

(*)6 K: Emission wavenumber (cm⁻¹)

Dimensional outline (unit: mm)

TO-8 package

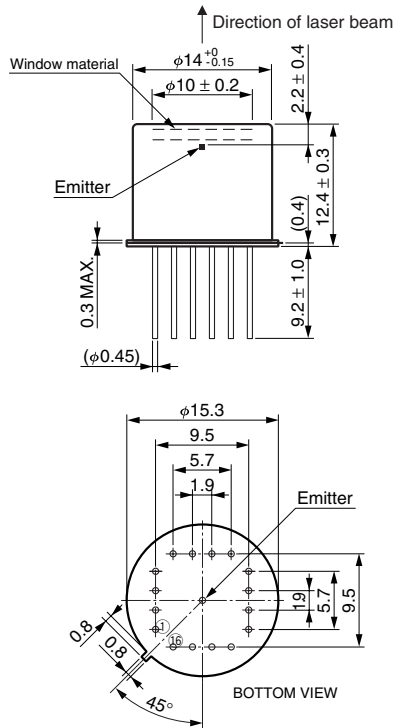

PIN No.	FUNCTION	PIN No.	FUNCTION	PIN No.	FUNCTION
①	TEC Cathode (-)	⑦	QCL Anode (+)	⑬	QCL Cathode (-)
②	N.C.	⑧	QCL Anode (+)	⑭	QCL Cathode (-)
③	N.C.	⑨	Thermistor (Top(qcl))	⑮	QCL Cathode (-)
④	TEC Anode (+)	⑩	Thermistor (Top(qcl))	⑯	QCL Cathode (-)
⑤	QCL Anode (+)	⑪	N.C.	—	—
⑥	QCL Anode (+)	⑫	N.C.	—	—

* All the pins are electrically isolated from the package.

Tolerance is ±0.1 mm unless specified.

Characteristics examples

●L12014-2231T-C

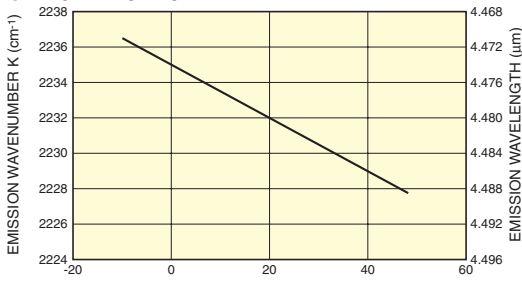

OPERATING TEMPERATURE (QCL) $T_{op(qcl)}$ (°C)

Parameter	Symbol	Condition	Typical value
Temperature coefficient of wavenumber	δK_T	I_p fixed	-0.15 $\text{cm}^{-1}/^\circ\text{C}$

●L12015-1901T-C

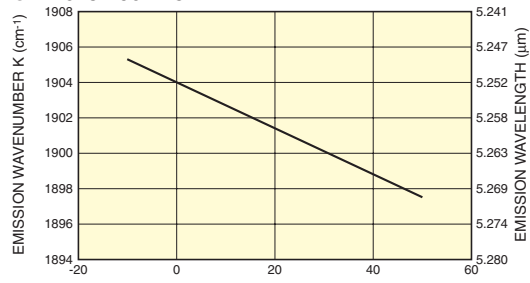

OPERATING TEMPERATURE (QCL) $T_{op(qcl)}$ (°C)

Parameter	Symbol	Condition	Typical value
Temperature coefficient of wavenumber	δK_T	I_p fixed	-0.13 $\text{cm}^{-1}/^\circ\text{C}$

●L12016-1630T-C

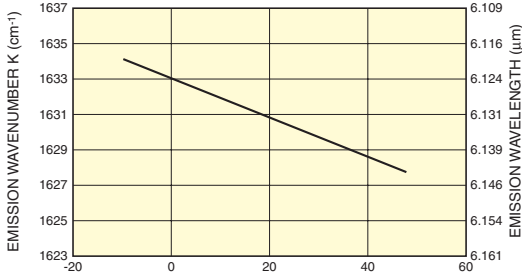

OPERATING TEMPERATURE (QCL) $T_{op(qcl)}$ (°C)

Parameter	Symbol	Condition	Typical value
Temperature coefficient of wavenumber	δK_T	I_p fixed	-0.11 $\text{cm}^{-1}/^\circ\text{C}$

●L12017-1278T-C

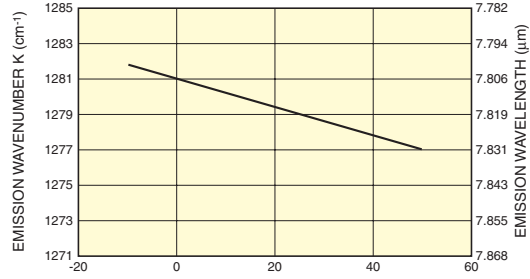

OPERATING TEMPERATURE (QCL) $T_{op(qcl)}$ (°C)

Parameter	Symbol	Condition	Typical value
Temperature coefficient of wavenumber	δK_T	I_p fixed	-0.08 $\text{cm}^{-1}/^\circ\text{C}$

●L12020-0993T-C

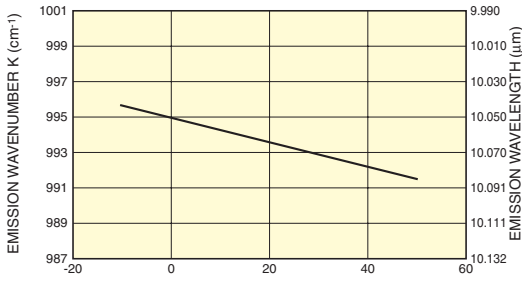

OPERATING TEMPERATURE (QCL) $T_{op(qcl)}$ (°C)

Parameter	Symbol	Condition	Typical value
Temperature coefficient of wavenumber	δK_T	I_p fixed	-0.07 $\text{cm}^{-1}/^\circ\text{C}$

CLASS 3R LASER

Invisible Laser Radiation: Avoid Direct Exposure of eyes to Beam

●The Laser emits invisible laser radiation. The instrument which used the LASER, operated under ordinary conditions, is classified as Class 3R according to the laser product classification code IEC 60825-1. See IEC 60825-1 for more details and safety operation concerning the above countermeasures.

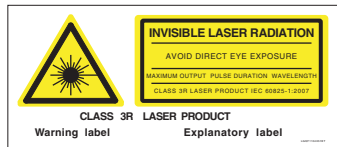

QCL LINEUP

■ Pulsed QCL Module



Pulsed QCL Module

The Pulsed QCL Module is a compact module containing a TO-8 can packaged pulsed DFB quantum cascade laser, pulse driver and TEC controller. The module can be easily and remotely controlled via Ethernet connection.

Type No.	Wave-length ^{(*)1}	Operating temperature (QCL) ^{(*)2}		Line width ^{(*)3}	Tunable range ^{(*)4}	Output power	Side-mode suppression ratio (SMSR)	Colimation lenses	Beam spread angle	Width of beam at waist ^{(*)5}
	Typ.	Min.	Max.	Max.	Min.	Typ.	Min.		Typ.	Typ.
L14147-1278-01	7.82 μm	+10 °C	+60 °C	1.0 cm ⁻¹	1.0 cm ⁻¹	100 mW	25 dB	Not included		
Condition: K=1278 cm ⁻¹ (*6)										
L14147-1278-02	7.82 μm	+10 °C	+60 °C	1.0 cm ⁻¹	1.0 cm ⁻¹	100 mW	25 dB	Included	3 mrad	1.5 mm
Condition: K=1278 cm ⁻¹ (*6)										

Standard driving conditions: $t_w=500$ ns, $f_r=100$ kHz, $T_{op}(qcl)=20$ °C

(*1) Please contact a Hamamatsu sales office about QCLs with emission wavelengths not listed above.

(*2) This specifies the temperature range within which the target emission wavenumber (K) can be realized.

(*3) Full-width half maximum

(*4) This specifies the continuous tunable range (without mode hopping). The center wavenumber of the tuning range is the emission wavenumber (K).

(*5) $1/e^2$ beam radius (*6) K: Emission wavenumber (cm⁻¹)

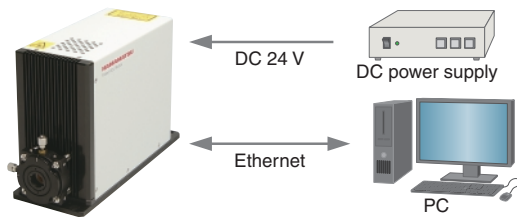

CLASS 3R LASER

Invisible Laser Radiation: Avoid Direct Exposure of eyes to Beam

● The Laser emits invisible laser radiation. The instrument which used the LASER, operated under ordinary conditions, is classified as Class 3R according to the laser product classification code IEC 60825-1. See IEC 60825-1 for more details and safety operation concerning the above countermeasures.

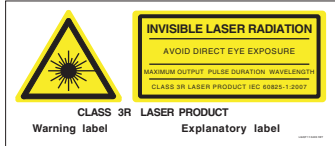

Dimensional outline (unit: mm)

• L14147-1278-01

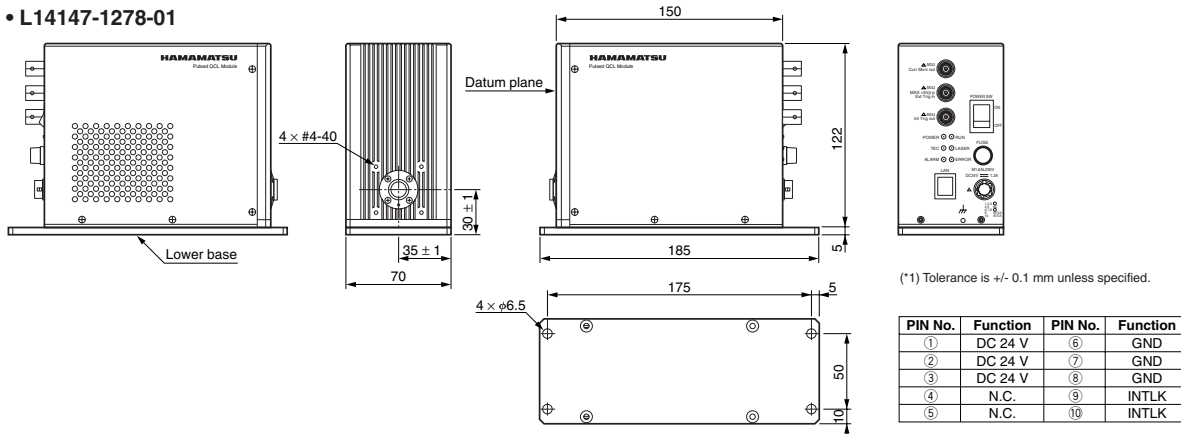

(*1) Tolerance is +/- 0.1 mm unless specified.

• L14147-1278-02 (with lens)

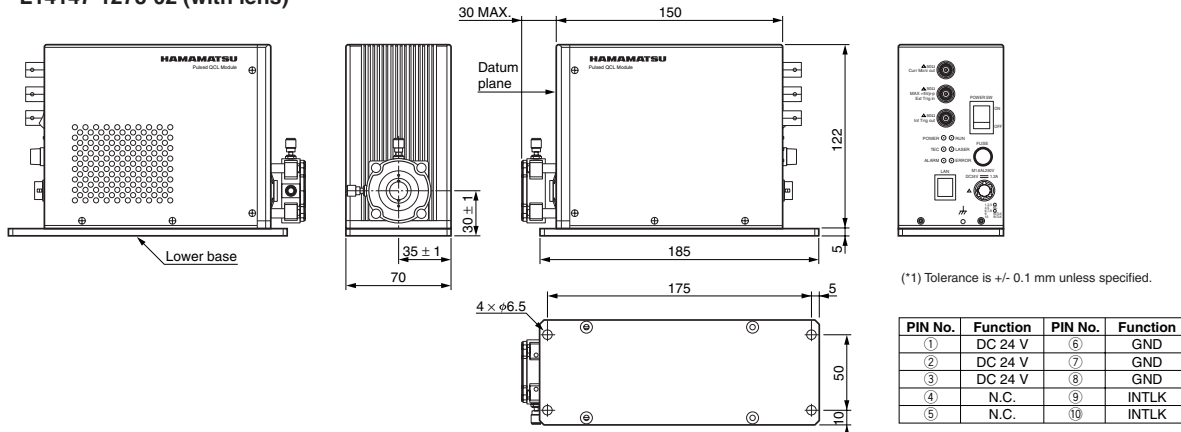

(*1) Tolerance is +/- 0.1 mm unless specified.

CONNECTION EXAMPLE

DFB-Pulsed QCL (1)

- ① DFB-Pulsed QCL (L12014, L12015, L12016, L12017 Series)
- ② TEC Driver C11330-02
- ③ TO-8 Pulsed Driver C11635
- ④ Aspheric ZnSe lens A11331-02 and/or Lens unit A11331-02H (*1)
- ⑤ Cable A11134-04
- ⑥ Heatseeker A10767 (*2)

DFB-Pulsed QCL (2)

- ① DFB-Pulsed QCL (L12020 Series)
- ② TEC Driver C11330-02
- ③ TO-8 Pulsed Driver C11635
- ④ Aspheric ZnSe lens A11331-01 and/or Lens unit A11331-01H (*1)
- ⑤ Cable A11134-04
- ⑥ Heatseeker A10767 (*2)

(*1) Select suitable lens based on the emission wavelength of the QCL to use.

(*2) Might not be used depending on the drive conditions.

Connection example of DFB-Pulsed QCL

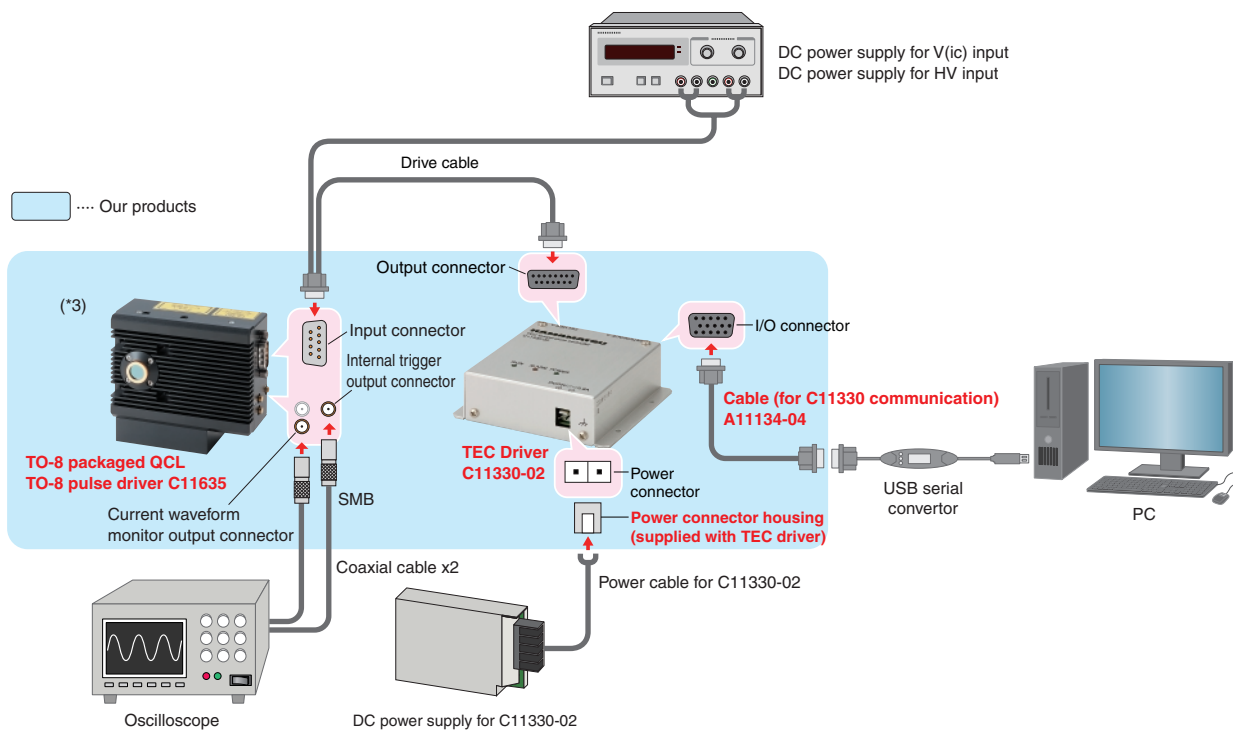

(*3) The photo is TO-8 Pulse Driver C11635 mounting a TO-8 packaged QCL.

- Products shown in photos are Hamamatsu products. Product names and part numbers are written in red.
- Prepare other necessary devices and cables.

PERIPHERAL INSTRUMENTS AND ACCESSORIES

HHL Mount A11709 Series



A11709-01 Forced air cooling

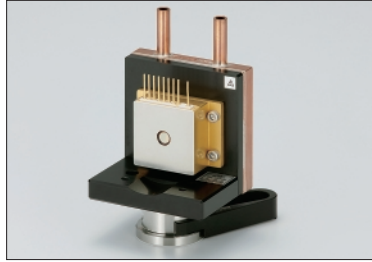

A11709-02 Water cooling

* Mounts shown in photos have HHL package QCL.

Cooling Unit for HHL packaged QCL. Two types of cooling, forced air and water, are available. An Aspheric ZnSe Lens Unit A11331-0xH can be mounted.

Parameter	A11709-01	A11709-02	Unit
Cooling method	Forced air cooling	Water cooling	—
Maximum heat discharge power	Approx. 30 ^(*)	Approx. 50 ^(*)	W
Thermal resistance	Approx. 0.5 ^(*)	Approx. 0.3 ^(*)	°C/W
Applicable package	HHL		—
Operating temperature	0 to +40		°C
Size (W × H × D)	68 × 82 × 117	60 × 103 × 50	mm
Weight	0.5	0.52	kg

(*) DC fan speed 7600 min⁻¹ at ambient temperature 25 °C

(**) Necessary flow rate and water temperature: 2000 cc/min. at 20 °C

- Features**
- Two types of cooling (water, forced air) are available.
 - Easy to mount
 - Easily set on optical tables
 - Can be mounted to the lens unit A11331-0xH

TO-8 Pulse Driver C11635



* Driver shown in photo has a TO-8 package QCL.

Pulsed QCL Driver for TO-8 packaged pulsed QCL. It outputs low noise pulsed current, and TO-8 packaged pulsed QCL can be mounted directly. An Aspheric ZnSe Lens Unit A11331-0xH can be mounted. Designed to be built into an instrument.

Parameter	Symbol	Value	Unit
Output current	Output current range	I(pulse)	0 to 3
	Pulse width (Typ.)	P _w	10
	Rise / fall time (Typ.)	T _r	5
	Repetition frequency	—	Approx. 150 kHz to Approx. 1 MHz
	Duty ratio	DR	<5
Dimensions (W × H × D)	—	90 × 68 × 43	mm
Weight	—	0.3	kg

* Can be mounted to aspheric lens unit A11331-0xH.

* Repetition frequency up to 2 MHz

* Pulse width down to 40 ns (repetition frequency < 500 kHz)

* Pulse width up to 1000 ns (repetition frequency < 100 kHz)

* External trigger operation by removing the oscillating board

* Two types of DC power supplies and a TEC driver are separately needed (see setup example below).

* An oscilloscope is separately needed for observation of current output shape.

* Bias source or TTL gate source should be separately prepared at the needs of usage.

Setup example

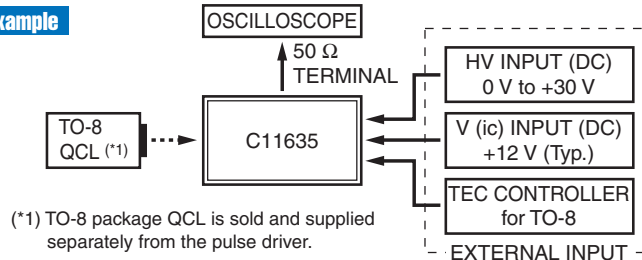

(*) TO-8 package QCL is sold and supplied separately from the pulse driver.

- Features**
- Mount TO-8 package QCL directly
 - Pulse width: 10 ns (Typ.)
 - Repetition frequency: <1 MHz
 - Low noise, high stability

TEC Driver C11330 Series



Peltier TEC (thermoelectric cooler) driver is used to control QCL temperature with high accuracy and high stability. Designed to be built into an instrument.

Parameter	C11330-01	C11330-02	Unit
Applicable package	HHL	TO-8	—
TEC output ^(*)	TEC control current	-8 to +8	A
	Compliance voltage	±24	
Temperature sensor ^(*)	Thermistor	NTC, 2 lines	
	RTD sensor	3-line platinum temperature measurement resistance (Pt100)	
Temperature control	Temperature control range (Thermistor/RTD)	-50 to +125 / -50 to +150	
	Setup resolution	0.01	
	Temperature stability	±0.01 (Typ.)	
	Control frequency	0.1 to 100	
Control algorithm	Digital PID loop ^(*)		—
Host interface	RS-232C, RS-422		—
Main body size (W × H × D)	100 × 110 × 33		mm
Weight	0.3		kg

(*) Actual output depends on characteristics of the connected load (TEL module), input power supply voltage, and current.

(*) Thermistor and Pt100 cannot be used simultaneously; select one of them.

(*) Auto-tuning function can be set by the host interface.

* A power supply (DC 24V), power cable, output cable, communication cable (A11134-04), terminal for control are separately needed.

* This product can only be controlled via serial communication.

* When controlling through a PC which does not have any ports or terminal emulators for serial communication, use an USB serial converter of HPK's recommendation (Windows7 or later). Supplied with sample software. (Windows XP, 7 or later).

- Features**
- High accuracy, high stability
 - Temperature stability: 0.01 °C
 - TEC heatsink monitoring function
 - Bipolar output, digital PID control

■Cables

●Cable (for HHL socket) A11134-01

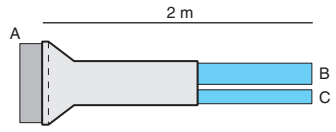

No.	A	B	C
Name	HHL connector	TEC drive cable	QCL drive cable
Terminal	9 pin socket	Cut-off 4PS (8 wires)	Cut-off 2PS (4 wires)
Connected to	HHL packaged QCL	C11330-01 (TEC driver)	DC power supply for CW semiconductor laser

Terminals B and C are to be modified in accordance with the type of TEC and power supply.

Pin layout

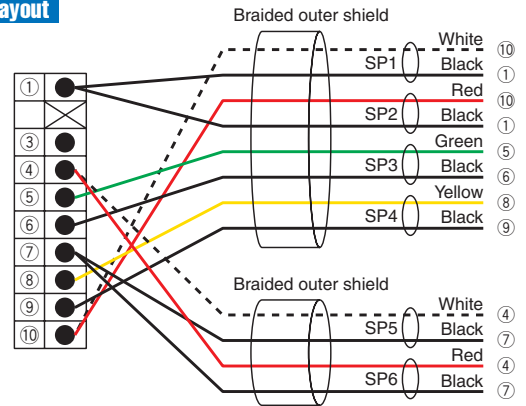

●Cable (for HHL socket) A11134-05



The B terminal connects to TEC Driver C11330-01. The C terminal is to be connected to Power Supply for laser.

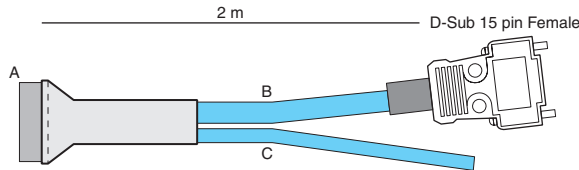

No.	A	B	C
Name	HHL connector	TEC drive cable	QCL drive cable
Terminal	9 pin socket	D-sub 15 pin (male)	Cut-off 2PS (4 wires)
Connected to	HHL packaged QCL	C11330-01 (TEC driver)	DC power supply for CW semiconductor laser

Dimensional outline (unit: mm)

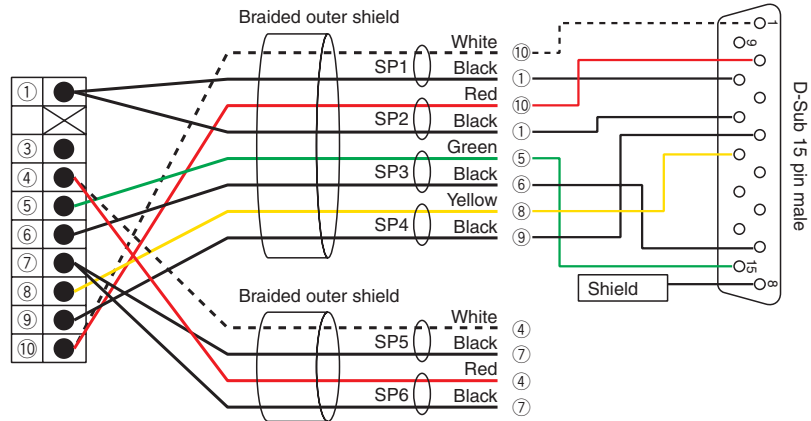

●Cable (for C11330 communication) A11134-04



Dimensional outline (unit: mm)

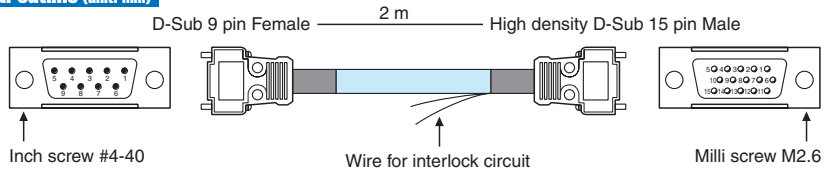

PC Side D-Sub 9 pin layout	
Pin No.	Signal
1	DCD
2	RxD
3	TxD
4	DTR
5	GND
6	DSR
7	RTS
8	CTS
9	RI

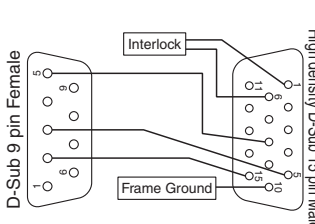

C11330 Side High density D-Sub 15 pin layout			
Pin No.	Signal	Pin No.	Signal
1	INTERLOCK	9	GND
2	ALARM	10	Frame Ground
3	RS-422 Rx+	11	START
4	RS-422 Tx+	12	STABLE
5	RS-232C Rx	13	RS-422 Rx-
6	GND	14	RS-422 Tx-
7	GND	15	RS-232C Tx
8	GND		

PERIPHERAL INSTRUMENTS AND ACCESSORIES

■ Lens / Lens Unit

Aspheric ZnSe lens designed for QCLs can be installed into Lens Unit A11331-0xH. The A11331-0xH series can be mounted onto HHL Mount A11709 series and TO-8 Pulsed Driver C11635. The A11331-0x series can also be used separately.

● Aspheric ZnSe Lens A11331-0x



* When using the lens by itself, a lens holder is required.

Parameter	Symbol	A11331-01	A11331-02	Unit
Primary design wavelength	λ	8	5	μm
Numerical aperture (NA)	NA	0.78		—
Effective diameter	CA	10		mm
Actual focal distance	EFL	4.8		mm
Working distance	WD	3.0		mm
Periphery	OD	14.9 to 15.0		mm
Center thickness	CT	6.4 ± 0.2	6.3 ± 0.2	mm
Edge thickness	ET	3		mm
Material	—	ZnSe		—
Refractive index	n	2.417 at $8 \mu\text{m}$	2.429 at $5 \mu\text{m}$	—
AR coating	—	BBAR, T (ave)>97 % (*1)	BBAR, T (ave)>96 % (*2)	—
Weight	—	5		g

(*1) T (ave): Average transmittance at 8-12 μm wavelengths

(*2) T (ave): Average transmittance at 4-8 μm wavelengths

Features

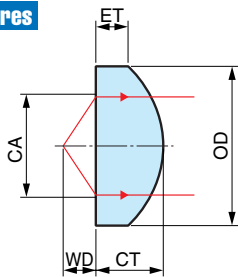

A11331-01
BBAR / 8 μm to 12 μm

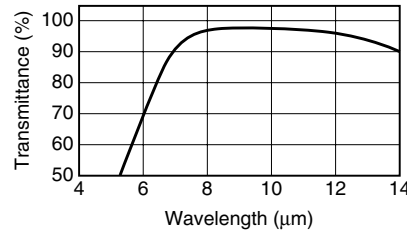

A11331-02
BBAR / 4 μm to 8 μm

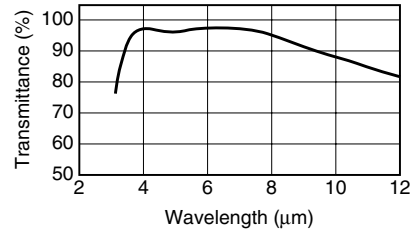

● Aspheric ZnSe Lens Unit A11331-0xH



Parameter	Value
Lens mounting unit	Applicable lens
XYZ translator	X/Y movable range
	A11331-01 or A11331-02
	$\pm 1 \text{ mm}$

x in the suffix of the part number indicates the type of embedded lens.

Usage example

A11331-0xH can be mounted on HHL Mount A11709 series and TO-8 Pulse Driver C11635.



Mounted on A11709-01

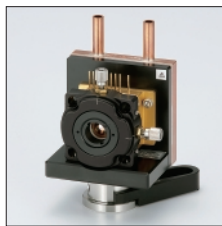

Mounted on A11709-02



Mounted on C11635

Dimensional outline (unit: mm)

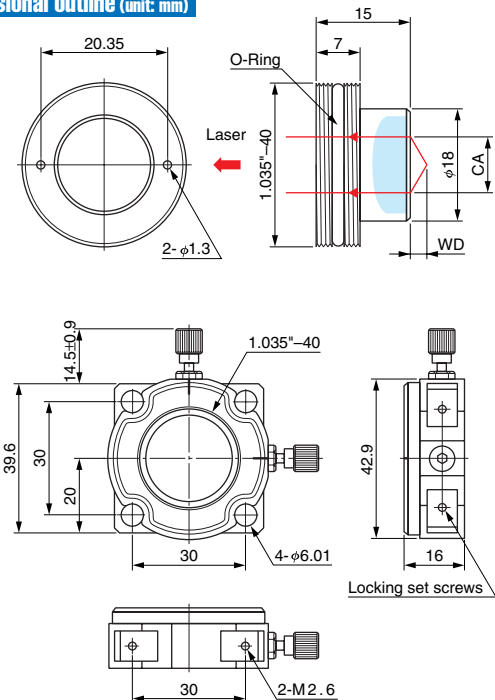

Heatseeker A10767

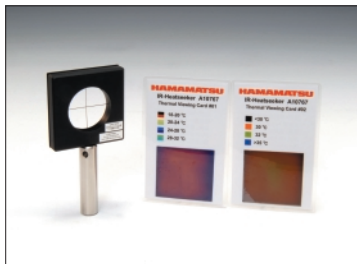

Heatseeker A10767 consists of 2 types of thermal viewing card and an alignment target. It can be used for visualization and alignment of the QCL laser beam.

Thermal Viewing Card

Thermal material provides visibility of the invisible IR laser beam and facilitates tracing of the beam. Two cards with different sensitivity ranges are provided.

Alignment Target

The light axis of the invisible IR laser beam can be easily aligned. Includes a cross target for checking the light axis. Thermal viewing card can be inserted.

Parameter		Description / value	Unit
Detectable temperature range	Thermal viewing card #01	18 to 32	°C
	Thermal viewing card #02	30 to 35	°C
Usable wavelength range		1.0 to 20	μm
Power required for visibility (*1)		>3	mW/mm ²
Damage threshold (Max. power density)		20	mW/mm ²
Maximum aperture		φ30	mm
Storage temperature		-5 to +60 (No condensation)	°C
Dimensions (W × H × D)		50 × 100 × φ12	mm

(*1) Average power density

Dimensional outline (unit: mm)

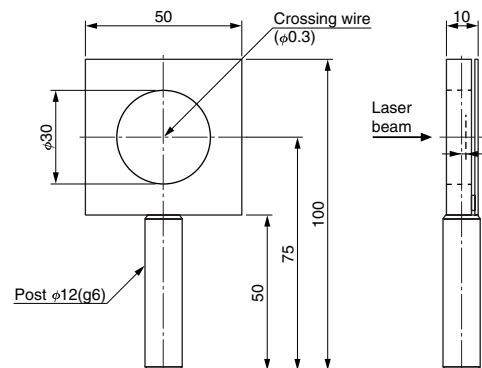

Reference

Absorption Spectra of Gases

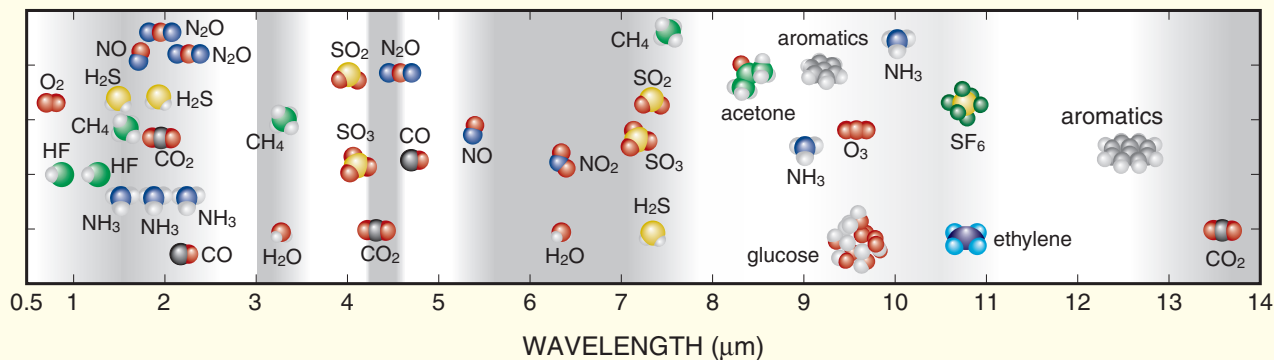

Wavelength	Gases	Suitable QCLs	
		DFB-CW type	DFB-Pulsed type
4.3 μm	¹² CO ₂ / ¹³ CO ₂	L12004-2310H-C	—
4.5 μm	N ₂ O, CO, CO ₂	—	L12014-2231T-C
4.5 μm	N ₂ O, CO	L12004-2190H-C	—
4.5 μm	N ₂ O	L12004-2209H-C	—
5.2 μm	NO	L12005-1900H-C	L12015-1901T-C
6.1 μm	NO ₂	L12006-1631H-C	L12016-1630T-C
7.2 μm	SO ₃	L12007-1392H-C	—
7.4 μm	SO ₂	L12007-1354H-C	—
7.8 μm	¹² CH ₄ / ¹³ CH ₄	L12007-1294H-C	—
7.8 μm	CH ₄ , N ₂ O	—	L12017-1278T-C
9.0 μm	NH ₃	—	—
9.6 μm	O ₃	—	—
10 μm	NH ₃	—	L12020-0993T-C

* This table does not guarantee the detection of each gas.

RELATED PRODUCTS

■ 760 nm DFB Laser Diodes



L13421-01



L13421-04

Distributed feedback laser diode contains an integrated grating structure to stabilize the wavelength. This product has narrow linewidth for oxygen sensing in comparison with Fabry-Perot laser diodes.

Read carefully before using QCL

For safe and effective use, carefully read the documents that come with your QCL and accessories. Read all manuals and instructions thoroughly and also be aware of local laser rules and regulations.

Warning

This catalog is not a guarantee of product perfection. When the products are used in an instrument which may cause bodily harm or damage property, it is dangerous to operate the instrument unless proper safety measures are taken against possible product defects.

Caution

● **Absolute maximum ratings**

Absolute maximum ratings listed in the specification sheet and/or test sheet are limiting values that must not be exceeded even momentarily. Using this product under conditions where any one of the maximum ratings is exceeded may cause serious and irreparable damage to the products.

Values in absolute maximum ratings for forward current and forward voltage differ in each product, so always check the values listed in the test sheet that comes with each product and make sure that these values are not exceeded.

● **Laser driver power supply**

Current surges and current fluctuations may impair performance of the laser device. Do not apply reverse current and reverse voltage to the QCL.

● **Heat dissipation**

This product uses a Peltier element to control temperature of the laser device, so the Joule heat generated in this product must be dissipated. If operated with poor heat dissipation, the device temperature may soon exceed the absolute maximum rating for the operating case temperature listed in specification sheet. Make sure that a proper heatsink is installed on the product. Poor heat dissipation may lead to excessive heating during operation and cause device deterioration or open-circuit faults even if the Peltier current is within the maximum rating. Heat dissipation on the laser side may not be sufficient when supplying electrical current to the Peltier element in heating mode, and cause failures or affect reliability. Carefully check these points before actual operation.

HAMAMATSU PHOTONICS K.K. www.hamamatsu.com

HAMAMATSU PHOTONICS K.K., Laser Group, Sales Dept.

1-8-3, Shinmiyakoda, Kita-ku, Hamamatsu City, Shizuoka, 431-2103, Japan, Telephone: (81)53-484-1301, Fax: (81)53-484-1302, E-mail: laser-g@lsr.hpk.co.jp

U.S.A.: Hamamatsu Corporation: 360 Foothill Road, Bridgewater, N.J. 08807-0910, U.S.A., Telephone: (1)908-231-0960, Fax: (1)908-231-1218 E-mail: usa@hamamatsu.com

Germany: Hamamatsu Photonics Deutschland GmbH: Arzbergerstr. 10, D-82211 Herrsching am Ammersee, Germany, Telephone: (49)8152-375-0, Fax: (49)8152-2658 E-mail: info@hamamatsu.de

France: Hamamatsu Photonics France S.A.R.L.: 19, Rue du Saule Trapu, Parc du Moulin de Massy, 91882 Massy Cedex, France, Telephone: (33)1 69 53 71 00, Fax: (33)1 69 53 71 10 E-mail: infos@hamamatsu.fr

United Kingdom: Hamamatsu Photonics UK Limited: 2 Howard Court, 10 Tewin Road, Welwyn Garden City, Hertfordshire AL7 1BW, United Kingdom, Telephone: (44)1707-294888, Fax: (44)1707-325777 E-mail: info@hamamatsu.co.uk

North Europe: Hamamatsu Photonics Norden AB: Torshamnsgatan 35 SE-164 40 Kista, Sweden, Telephone: (46)8-509-031-00, Fax: (46)8-509-031-01 E-mail: info@hamamatsu.se

Italy: Hamamatsu Photonics Italia S.r.l.: Strada della Moia, 1 int. 6, 20020 Arese (Milano), Italy, Telephone: (39)02-93581733, Fax: (39)02-93581741 E-mail: info@hamamatsu.it

China: Hamamatsu Photonics (China) Co., Ltd.: B1201 Jiaming Center, No.27 Dongsanhuan Beilu, Chaoyang District, Beijing 100020, China, Telephone: (86)10-6586-6006, Fax: (86)10-6586-2866 E-mail: hpc@hamamatsu.com.cn

Taiwan: Hamamatsu Photonics Taiwan Co., Ltd.: 8F-3, No.158, Section2, Gongdao 5th Road, East District, Hsinchu, 300, Taiwan R.O.C. Telephone: (886)03-659-0080, Fax: (886)07-811-7238 E-mail: info@tw.hpk.co.jp

Cat. No. LQCL2001E06
AUG. 2016 IP
(500)